

C&I Energy Storage 2MWh Series Warranty Service Terms

Document Version 01
Release Date 2024-04-28



Copyright © Huawei Technologies Co., Ltd. 2024. All rights reserved.

Without the written permission of the Company, no unit or individual may extract or copy part or all of the contents of this document, and may not disseminate it in any form.

Trademark Claims



HUAWEI and other Huawei trademarks are trademarks of Huawei Technologies Co., Ltd.

All other trademarks or registered trademarks mentioned in this document are the property of their respective owners.

note

The products, services, or features that you purchase are subject to Huawei's commercial contracts and terms. All or part of the products, services, or features described in this document may not be within your purchase or use scope. Unless otherwise specified in the contract, Huawei does not make any express or implied representations or warranties in this document.

This document is subject to irregular updates due to product version upgrades or other reasons. Unless otherwise agreed, this document is intended for guidance only and all statements, information and recommendations in this document do not constitute any warranty, express or implied.

Huawei Technologies Co., Ltd.

Address: Huawei Headquarters Office Building, Bantian, Longgang District, Shenzhen 518129

Website: <https://e.huawei.com>

修改记录

| Date | Issue | Description | Author | Reviewer |
|------------|-------|---|------------------------|---|
| 2024-03-26 | 1.0 | Initial draft, applicable only to ESSs. | Lu Haiyang 84244610 | Weizheng 00832516 Mawei 00635077 |

Table of Contents

| | |
|---|------------|
| Table of Contents | iii |
| 1 Applicable Product Model | 1 |
| 2 Warranty Scope | 2 |
| 2.1 Performance Guarantee..... | 2 |
| 2.2 Product warranty..... | 3 |
| 3 Warranty Period Description | 7 |
| 3.1 General Description of Warranty Period..... | 7 |
| 3.2 Warranty Service Description | 错误!未定义书签。 |
| 4 Warranty clause | 13 |
| 4.1 Basic Provisions..... | 13 |
| 4.2 Exception clause..... | 14 |

1 Applicable Product Model

China: LUNA2000-2.0MWH-2H1(0.5C);

Regions outside China: LUNA2000-2.0MWH-1H1(1C)、LUNA2000-1.0MWH-1H1(1C)、LUNA2000-2.0MWH-2H1(0.5C);

Huawei industrial and commercial energy storage products (ESSs for short) are applicable to industrial and commercial scenarios. They work with the SmartPCS, DC-DC, and SACU. The SmartPCS connects to the DCDC. When the power grid is sufficient, the SmartPCS charges batteries. When the power grid requires output, the SmartPCS outputs the stored battery energy to loads.

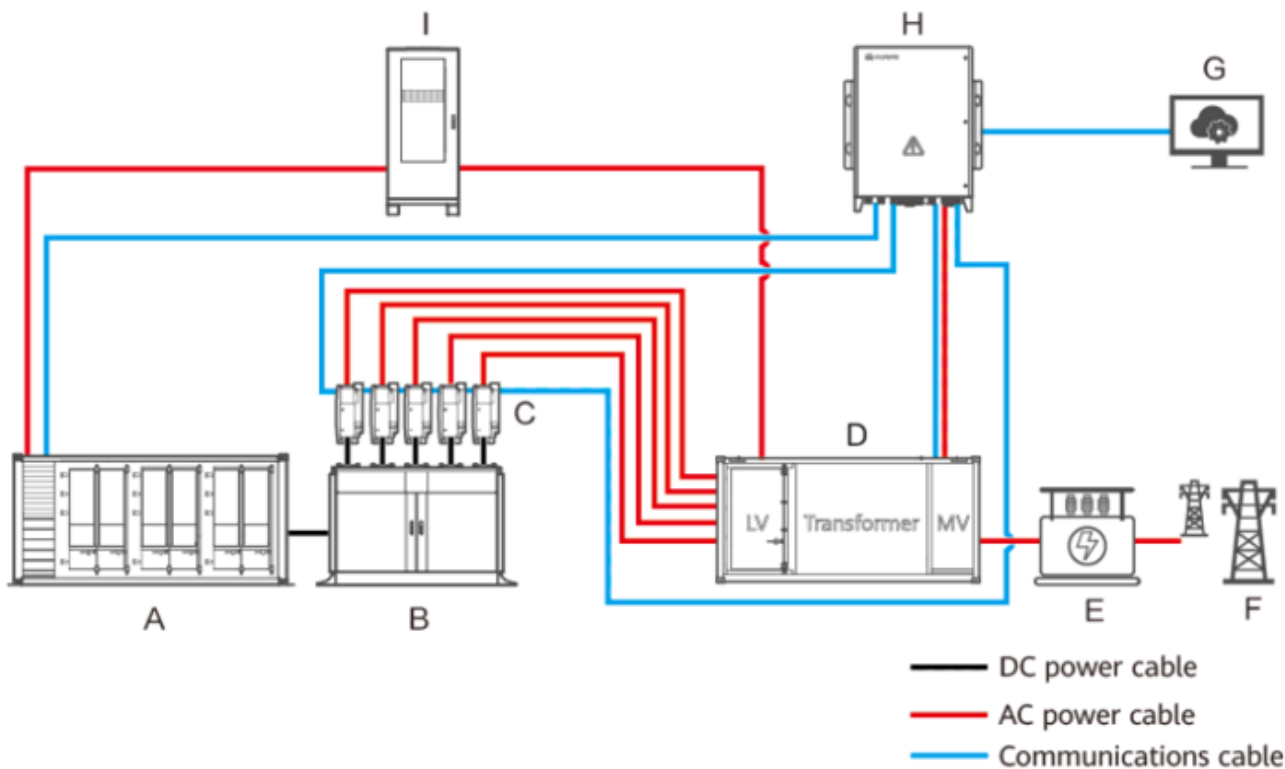

2 Warranty Scope

2.1 Performance warranty

Performance warranty defined for the ESS: 100% DOD, 60% capacity at EOL, operating temperature range of $-30^{\circ}\text{C}\sim+30^{\circ}\text{C}$, The number of cycles is defined according to the working conditions of each area. For details, see Table 2-1.

The performance warranty of the battery module is based on the ten-year warranty period and the number of cycles. The one that reaches the warranty first takes effect, and the warranty expires.

Energy storage warranty includes product warranty and performance warranty, which are provided separately. The product warranty period does not affect the battery performance warranty.

Capacity test conditions: At an ambient temperature of $25^{\circ}\text{C}\pm 3^{\circ}\text{C}$, fully discharge the batteries, charge them to 100% SOC at a rate of 0.5C, discharge them to end-of-discharge SOC at a rate of 0.5C, and record the discharged energy.

The ESS must be connected to the Huawei PV cloud and remotely upgraded to the latest firmware version in a timely manner to ensure the service life of electrochemical cells. For energy storage products that are not connected to Huawei PV cloud, the electrochemical cell damage caused by the failure to upgrade in time will not be covered by the warranty.

The following table lists the quality assurance standards for non-standard charge and discharge coefficients in typical working conditions of the reduced version of the industrial and commercial energy storage system.

Table 2-1 Performance warranty standards for the ESS under typical working conditions

| Regions | Model | charge and discharge coefficient | Number of cycles | Standard working conditions | Remarks |
|---------------|---------------------|----------------------------------|------------------|--|---|
| China Region | LUNA2000-2.0MWH-2H1 | 0.5C | 8030 | Two charges and two discharges per day | For other working conditions, see related documents of performance commitment baseline. |
| Outside China | LUNA2000-2.0MWH-1H1 | 0.5C | 6570 | One charge and one discharge every day | |
| | LUNA2000-2.0MWH-1H1 | 1C | 4400 | | |
| | LUNA2000-1.0MWH-1H1 | 1C | 4400 | | |

NOTE

For details about performance under non-typical working conditions, see related documents about performance commitment baselines, which are not used as product warranty standards.

2.2 Product warranty

the product warranty of the industrial and commercial energy storage 2 MWh system is classified into basic warranty and advanced warranty. After the device is delivered, the basic warranty is automatically obtained. If the device is connected to Huawei PV cloud or purchased from Huawei for five years, the warranty is upgraded to advanced warranty.

Table 2-2 Basic warranty period of each product series (year)

| Equipment | Subdevice | Europe | Japan | China | Middle East and Central Asia | Asia Pacific | Latin America | Southern Africa | Northern Africa | Country B |
|-------------|--|--------|-------|-------|------------------------------|--------------|---------------|-----------------|-----------------|-----------|
| Equipment | Intelligent String Energy Storage System (ESS) | 2 | 2 | 2 | 2 | 2 | 2 | 2 | 2 | 2 |
| | DCDC | | | | | | | | | |
| | PCS | | | | | | | | | |
| | Fire extinguishing module | | | | | | | | | |
| Attachments | SACU/SmartLogger | 1 | 1 | 1 | 1 | 1 | 1 | 1 | 1 | 1 |

The following auxiliary materials and mechanical parts are not covered by the warranty:

| Category | Description |
|----------------------------------|--|
| Consumables | Including but not limited to cables, door padlocks, lamps, batteries (small batteries other than battery packs) |
| Cables | Cables between cabinets; |
| Mechanical parts | Including, but not limited to, battery racks and mechanical components |
| Accessories for battery cabinets | Including but not limited to cabinet mechanical parts, documents, product accessories, installation accessories, and tools |

Connect the industrial and commercial energy storage 2 MWh system to Huawei PV cloud or purchase the five-year offline inspection service and upgrade the warranty to the advanced warranty.

Details are as follows:

Table 2-3 Advanced warranty period of each product series (year)

| Equipment | Subdevice | Europe | China | Middle East and Central Asia | Asia Pacific | Latin America | Southern Africa | Northern Africa |
|-----------|--|--------|-------|------------------------------|--------------|---------------|-----------------|-----------------|
| Equipment | Intelligent String Energy Storage System (ESS) | 5 | 5 | 5 | 5 | 5 | 5 | 5 |
| | DCDC | | | | | | | |
| | PCS | | | | | | | |

| | | | | | | | | |
|-------------|---------------------------|---|---|---|---|---|---|---|
| | Fire extinguishing module | | | | | | | |
| Attachments | SACU/SmartLogger | 2 | 1 | 2 | 2 | 2 | 2 | 2 |

The following auxiliary materials and mechanical parts are not covered by the warranty:

| Category | Description |
|----------------------------------|--|
| Consumables | Including but not limited to cables, door padlocks, lamps, |
| Cables | Cables between cabinets; |
| Mechanical parts | Including, but not limited to, battery racks and mechanical components |
| Accessories for battery cabinets | Including but not limited to cabinet mechanical parts, documents, product accessories, installation accessories, and tools |

Table 2-4 Warranty period start dates

| Start mode | Europe | China | Middle East and Central Asia | Asia Pacific | Latin America | Southern Africa | Northern Africa |
|---|--------|-------|------------------------------|--------------|---------------|-----------------|-----------------|
| Warranty start date: The warranty period starts from the 90th day after Huawei's product is delivered or the date when Huawei receives the service request for the product (whichever is earlier). The warranty period is applicable to project-based products. | √ | √ | √ | √ | √ | √ | √ |
| Warranty Start Date: The warranty period starts from the 180th day from the date when Huawei products are shipped or the date when Huawei receives the service request for the products (whichever is earlier) - Applicable to distribution products | √ | √ | √ | √ | √ | √ | √ |

NOTE

1. If the warranty period of equipment starts from the shipment date, this item must be specified in the contract.
2. For channel sales projects, channel partners must complete necessary ESS capability certification.

3. For channel distribution projects, channel partners are responsible for notifying customers of technical requirements such as transportation, storage, site selection, installation space, and foundation construction requirements. Such content must be included in the contract. Huawei will not be responsible for any problems caused by ignorance of the preceding requirements.
4. The spare parts of the ESS are replaced by parts replacement, which does not affect the warranty period of the entire system.
5. The warranty period of spare parts such as the SmartLogger complies with the original rules of the region.

Table 2-5 Standard warranty services

| Category | Service | Description |
|--------------------------|--|---|
| Remote technical support | Hotline service | China/Other countries outside China: 24 x 7 |
| | Remote troubleshooting | China: 12x7 Other countries outside China: 9x5 |
| | Online technical support | Technical information sharing and patch download |
| | Multi-channel support | Including social media |
| Software support | Software update authorization | Device firmware maintenance version (patch and beta versions) |
| Hardware support | Lithium Battery Spare parts replacement | For the spare part SLA of ESS battery module, refer to the SLA policy table below. After approving the customer's spare parts service application, Huawei will send the replacement parts within the working days specified in the corresponding SLA. The customer only needs to return the faulty parts to the place designated by Huawei within 15 business days after receiving the replacement parts from Huawei. If the faulty parts are not returned within the specified period, it is deemed that the customer purchases the parts at the list price. If any damage or loss occurs during the return via a courier, the customer shall be liable for the consequences. |
| | Non- Lithium Battery Spare parts replacement | After approving the customer's spare parts service application, Huawei will send the replacement parts within two business days. The customer only needs to return the faulty parts to the place designated by Huawei within 15 business days after receiving the replacement parts from Huawei. If the faulty parts are not returned within the specified period, it is deemed that the customer purchases the parts at the list price. If any damage or loss occurs during the return via a courier, the customer shall be liable for the consequences. |
| Replacement compensation | Compensation for spare parts replacement | Based on the competition situation, after the installer provides the spare parts replacement service, Huawei pays part of the fee to compensate the installer for the onsite service. (Region-specific service strategy, not mandatory) |

 **NOTE**

- 24/7: Monday to Sunday, 00:00–24:00
- 12/7: Monday to Sunday, 8:00–20:00
- 9/5: business days, 9:00–18:00, excluding public holidays
- The basic warranty does not include on-site services. If on-site problem handling is required, on-site services must be purchased.;
- Regional Lithium Battery Spare Parts Service SLA Policy:

Table 2-6 Regional lithium battery spare parts service SLA strategy

| Regions | Europe | China | Middle East and Central Asia | Asia Pacific | Latin America | Southern Africa | Northern Africa |
|---------------------|-----------------|-------|------------------------------|-----------------|---------------|-----------------|-----------------|
| Battery spare parts | 2~5BD* 2BD-S | 2BD-S | 2BD-S** | 2~5BD* 2BD-S | 2BD-S** | 2~5BD* 2BD-S | 2BD-S |

 **NOTE**

- BD: business day
- 2BD-S: Huawei ships spare parts within two business days after confirming the necessity of hardware replacement and receiving the RMA information.
- 2BD: The spare parts are delivered to the place designated by the customer within two working days after Huawei confirms that hardware replacement is necessary and provides the RMA number.
- *: Huawei delivers the spare parts to the place designated by the customer within two to five business days after confirming the necessity of hardware replacement and receiving the RMA information.
- **: 3 countries in Europe (Spain, Germany, United Kingdom), 10 countries in Latin America (Paraguay, Uruguay, Brazil, Guatemala, Jamaica, Nicaragua, Dominica, Mexico, Chile, Peru), 6 countries in Asia Pacific (Bangladesh, Indonesia, Thailand, Malaysia, Myanmar, Singapore) and Senegal, South Africa Can promise 2BD-S.

3 Warranty Period Description

3.1 General Description of Warranty Period

Rules for starting warranty for C&I ESSs: The warranty period starts 90 days after Huawei shipment or the date when the customer applies for warranty triggering (not later than 90 days after shipment).

Huawei provides the warranty extension service. The customer can purchase the 5-year warranty only when the PV plant is connected to Huawei PV cloud or offline inspection is purchased.

In principle, the product warranty period must be continuous from the date of purchase. Otherwise, extension warranty is not supported.

The warranty extension time of each sub-component is as follows:

| Category | Equipment | Europe | China | Middle East and Central Asia | Asia Pacific | Latin America | Southern Africa | Northern Africa | Country B |
|-------------|--|--|-------|------------------------------|--------------|---------------|-----------------|-----------------|-----------|
| Equipment | Intelligent String Energy Storage System (ESS) | 5 | 5 | 5 | 5 | 5 | 5 | 5 | 5 |
| | DCDC | | | | | | | | |
| | PCS | | | | | | | | |
| | Fire extinguishing module | | | | | | | | |
| Attachments | Smartlogger | Supports the same warranty period from purchase to the time when the energy storage system is purchased. | | | | | | | |

NOTE

- The extended warranty for C&I ESSs can be purchased within the warranty period. If the extended warranty is purchased in addition to the advanced warranty, the maximum total warranty period is 10 years.

3.1.1 Overall situation

Table 3-1 Basic Extended Warranty Service Contents

| Service Category | Service Items | Service Description |
|---------------------------|---|---|
| Remote technical support | Hotline handling | China/other countries outside China: 24 x 7 |
| | Remote CSR handling | China: 12 x 7; Other countries outside China: 9 x 5 |
| | Online technical support | Technical information sharing and patch downloading |
| Software Support Service | Software Update Authorization | Provide device firmware maintenance version (patch and minor version) |
| Hardware Support Services | Pre-replacement of battery spare parts | For details about the spare part SLA of the battery module, see Table 2-6. After Huawei approves the customer's spare parts service application, Huawei delivers the replacement parts within the working days specified in the corresponding SLA. The customer only needs to return the faulty parts to the designated receiving point within 15 working days after receiving the replacement parts provided by Huawei. If the faulty parts are not returned within the specified period, the customer will purchase the faulty parts at the list price. If the customer is damaged or lost during the mailing process, the customer shall bear the relevant responsibility. |
| | Pre-replacement of non-energy storage spare parts | After Huawei approves the customer's spare parts service application, Huawei delivers the replacement parts within two working days. The customer only needs to return the faulty parts to the designated receiving point within 15 working days after receiving the replacement parts provided by Huawei. If the faulty parts are not returned within 15 working days, the customer will purchase the faulty parts at the list price. If the customer is damaged or lost during the mailing process, the customer shall bear the relevant responsibility. |

说明

- 9x5: weekdays, 9:00 - 18:00, excluding legal holidays.
- 7x12: Monday to Sunday, 8:00 to 20:00 (all days, all holidays).
- 7x24: Mon-Sun, 00:00 - 24:00.
- The spare parts service delivery process, responsibilities, and restrictions must comply with the spare parts service requirements of the Carrier BG.;
- The basic extended warranty does not include onsite service. If onsite problem handling is required, the single onsite service must be purchased separately.。

3.1.2 Spare Parts Service Description

- The 2 MWh series of industrial and commercial energy storage systems, SACUs, DCBOX, and spare parts are replaced by parts by default.
- The local warehouse does not store a large number of spare lithium batteries to ensure the

maintenance and replacement turnover. If the local country does not have the charging and discharging capabilities and is not charged after the expiration date, the spare lithium batteries will be scrapped.

- In remote areas or projects where availability is promised to the customer, it is recommended that the customer prepare 0.5% of the equipment on site to shorten the recovery time of the plant equipment.
- In areas where spare parts can be reached, the central spare parts center and representative office warehouse provide spare parts delivery assurance.
- According to the product sales contract or service contract, the customer is responsible for returning the faulty parts.
- It is prohibited to promise to build local spare parts warehouses for customers in areas where there is no local Huawei representative office or legal Huawei organization. It is prohibited to promise to build dedicated spare parts warehouses or reserve dedicated spare parts for customers. It is prohibited to promise to provide spare parts services for customers according to the service agreement.
- The spare parts SLA in the service contract cannot exceed the local spare parts service delivery capability or the highest service SLA that can be expanded locally.
- The spare parts in the spare parts center cannot be directly sold to customers. The spare parts are used only for spare parts service delivery. The sales of spare parts for out-of-warranty services is a marketing activity. If a customer wants to purchase spare parts, the customer needs to sign a sales contract. The supply chain delivers the spare parts to the customer according to the sales contract.
- If Huawei does not have a registered subsidiary and does not have the import and export qualification, Huawei cannot perform import and export business as the customs clearance entity for equipment or spare parts, and cannot provide spare parts replacement or spare parts pre-replacement services for customers in the name of Huawei. Only the spare parts repair service can be provided to customers. (If the faulty part cannot be repaired, Huawei provides the good part to the customer.), and the customer is responsible for the import and export customs clearance of the equipment;
- When providing spare parts services, Huawei only promises to provide good parts and does not promise to provide new parts.
- The warranty period of spare parts in each country is as follows: :

| Product | Patterns | Europe | China | Middle East and Central Asia | Asia Pacific | Latin America | Southern Africa | Northern Africa |
|---------|----------|--------|-------|------------------------------|--------------|---------------|-----------------|-----------------|
| | | | | | | | | |

| | | | | | | | | |
|--|---|---|---|---|---|---|---|---|
| Industrial and commercial energy storage 2MWh series systems | Warranty period of spare parts for industrial and commercial energy storage 2 MWh series systems: warranty period of original equipment | | √ | | | | | |
| | Warranty period of spare parts for industrial and commercial energy storage 2 MWh series systems: 180 days from the date of delivery of spare parts or the warranty period of original equipment (whichever is later) | | | | √ | | | |
| | Warranty period of spare parts for industrial and commercial energy storage 2 MWh series systems: 360 days from the date of delivery of spare parts or the warranty period of original equipment (whichever is later) | √ | | √ | | √ | √ | √ |
| SmartLogger and other accessories | Warranty period of spare parts such as the SmartLogger: warranty period of the original equipment | | √ | | | | | |
| | Warranty period of spare parts such as the SmartLogger: 90 days from the date when the spare parts are delivered or the warranty period of the original equipment (whichever is later) | √ | | √ | | | √ | √ |
| | Warranty period of spare parts such as the SmartLogger: 180 days from the date when the spare parts are delivered or the warranty period of the original equipment (whichever is later) | | | | √ | √ | | |
| | Warranty period of spare parts such as the SmartLogger: 360 days from the date when the spare parts are delivered or the | | | | | | | |

| | | | | | | | | |
|--|--|--|--|--|--|--|--|--|
| warranty period of the original equipment (whichever is later) | | | | | | | | |
|--|--|--|--|--|--|--|--|--|

* Note: In category B, Canada is listed in the following table. For other countries, see the preceding table.

Warranty period of spare parts for industrial and commercial energy storage 2 MWh series systems: 180 days from the date of delivery of spare parts or the warranty period of original equipment (whichever is later). Warranty period of spare parts such as the SmartLogger: 180 days from the date when the spare parts are delivered or the warranty period of the original equipment (whichever is later).

3.1.3 Remote Support Services

Remote technical support refers to the technical support provided by Huawei by telephone or email for Huawei product problems. Including Huawei hotline, remote technical support, and online technical support.

Hotline

Receives and tracks service requests based on the service interface platform.

For details about the hotline number, see the official Huawei Digital Energy website. If there is no hotline in a country, please contact the hotline of a neighboring country.

Email: eu_inverter_support@huawei.com.

Remote technical support

Including technical consultation and problem handling. Technical consultation refers to the technical guidance for non-actual problems. Problem handling refers to the solution to product-related problems and provides solutions to customers within the promised service time.

Online Technical Support

Huawei provides website access support services. Customers can log in to (<http://www.huawei.com/en/all-products/Solar>), and provide O&M experience introduction, cases, and technical documents related to products.

Multi-channel support

Customers can add Huawei Digital Energy official account on the multimedia platform to obtain more technical support information.

3.1.4 Software Support Services

If necessary, Huawei provides software update guidance services for customers free of charge within the warranty period.

Huawei guarantees that the Products are in good operation, but does not guarantee that the Software is error-free or uninterrupted, nor that Huawei will correct all program errors.

3.1.5 Hardware Support Services

Hardware is a prerequisite for the stable running of the ESS. Huawei hardware support service ensures the stable operation of the ESS.

4 Warranty clause

4.1 Basic Provisions

During the warranty period, Huawei promise as follows:

- 4.1.1 Provide replacement service when normal functions cannot be used due to defects in materials, manufacturing or workmanship.
- 4.1.2 Provide replacement service when normal functions cannot be used due to non-compliance with published product specifications.
- 4.1.3 Huawei spare parts (excluding batteries) shall be delivered within two working days after the service request is confirmed. After receiving the spare parts, the asset ownership of the faulty parts will be transferred to Huawei. The customer shall return the faulty parts to Huawei within 15 working days. If the faulty parts cannot be returned, the customer must compensate Huawei for the loss.
- 4.1.4 If Huawei provides spare parts in the order, the customer is not allowed to sell the spare parts to third parties or use them for other purposes.
- 4.1.5 Spare parts provided by Huawei are equivalent to those used by customers on site.
- 4.1.6 After Huawei provides spare parts, the system warranty period inherits or is not shorter than the warranty period in the original contract.
- 4.1.7 Onsite engineering operations are completed by the customer, and Huawei is not responsible for onsite replacement.
- 4.1.8 After the spare parts request is confirmed, Huawei is responsible for the transportation of spare parts within the warranty period.
- 4.1.9 If a product fault is found within the warranty scope, the customer should contact Huawei hotline to report the fault and provide the following information:
 - 1. Brief description of the fault, including but not limited to input and output parameters, alarm ID, cause ID, and run logs.

2. Product serial number.
3. Purchase receipt.

The above information is the condition for reporting faults.

4.1.10 If the customer does not provide sufficient information or the spare parts are replaced without Huawei's confirmation, the customer shall bear the freight.

4.2 Exception clause

4.2.1 The preceding support services are only applicable to Huawei-produced equipment. The hardware equipment beyond the agreed scope is not covered by Huawei's service scope.

4.2.2 In all cases, whether on the basis of contract, warranty, tort (including liability for fault and strict liability) or any other theory and legal claim, Huawei does not assume any liability for any consequences arising from the installation, use, or poor performance of its products, any indirect loss, collateral damage, or punitive damages arising from any defect or breach of warranty. including, but not limited to, loss of profits, damage to goodwill or business reputation, or loss of delay. The total amount of Huawei's responsibility for damages or otherwise shall not exceed the purchase price paid by the original Buyer for the Products.

4.2.3 Huawei commercial and industrial energy storage systems have a two-year basic warranty by default. A 5-year advanced warranty can be provided only when they are connected to Huawei PV cloud or purchasing for five-year offline inspection. If the customer fails to connect to Huawei management system for more than three months, Huawei has the right to cancel the advanced warranty.

4.2.4 Widely used vulnerable parts and consumables are not covered by Huawei's service scope.

4.2.5 If Huawei cannot fulfill the service commitment within the promised time due to non-Huawei reasons, the customer shall exempt Huawei from the SLA fulfillment responsibilities and relevant compensations. If on-site services are required, travel time shall be excluded from SLA time.

4.2.6 Faults caused by the following reasons are not covered by Huawei's service scope:

- Damages to Huawei devices due to force majeure, such as natural disasters, fires, and wars
- Damages to Huawei devices due to normal wear and tear
- Direct damages caused by failure to comply with the written requirements on the operating environment or external electrical specifications
- AC or DC connectors broken, damaged, or burnt due to the poor engineering quality of the connectors
- Damages caused by lightning due to improper system design
- Large-scale damages to Huawei hardware or data due to customer's negligence, improper operation, or intentional sabotage

- Damages caused by customer's failure to transport, store, install and operate Huawei products in accordance with the user manuals
- ESS performance degradation caused by leaving idle batteries uncharged for 6 months or longer, or battery cell damages caused by leaving batteries uncharged for extended periods, which will not be covered by the warranty
- Damages caused by improper operation or failure to comply with the temperature requirements during transportation or operation
- Damages caused by maintenance or other services performed by personnel not authorized by Huawei
- System damages caused by improper operations of a third party or customer, including system migration and installation performed in violation of Huawei's requirements, and adjustment, alteration, and removal of identification signs performed in violation of Huawei's requirements
- System damages caused by customer's infrastructure problems
- Battery cell damages caused by outdated firmware due to the customer's failure to connect the ESS to Huawei's management system, which will not be covered by the warranty
- Failure to install or operate Huawei equipment, project scenarios, third-party equipment, etc. in compliance with the conditions, requirements or restrictions in Huawei solutions documents.