

**SmartMGC5000**

# **User Manual**

**Issue**            03  
**Date**             2025-12-20



**Copyright © Huawei Technologies Co., Ltd. 2025. All rights reserved.**

No part of this document may be reproduced or transmitted in any form or by any means without prior written consent of Huawei Technologies Co., Ltd.

## **Trademarks and Permissions**



HUAWEI and other Huawei trademarks are trademarks of Huawei Technologies Co., Ltd.

All other trademarks and trade names mentioned in this document are the property of their respective holders.

## **Notice**

The purchased products, services and features are stipulated by the contract made between Huawei and the customer. All or part of the products, services and features described in this document may not be within the purchase scope or the usage scope. Unless otherwise specified in the contract, all statements, information, and recommendations in this document are provided "AS IS" without warranties, guarantees or representations of any kind, either express or implied.

The information in this document is subject to change without notice. Every effort has been made in the preparation of this document to ensure accuracy of the contents, but all statements, information, and recommendations in this document do not constitute a warranty of any kind, express or implied.

## **Huawei Technologies Co., Ltd.**

Address: Huawei Industrial Base  
Bantian, Longgang  
Shenzhen 518129  
People's Republic of China

Website: <https://e.huawei.com>

# About This Document

## Purpose





This document describes the SmartMGC5000 (SmartMGC for short) in terms of installation, electrical connections, system operation, maintenance, and troubleshooting. Readers shall understand the SmartMGC features, functions, and safety precautions provided in this document before installing and operating the SmartMGC.

## Intended Audience

This document is intended for operating personnel and qualified electricians of photovoltaic (PV) and energy storage systems.

## Symbol Conventions

The symbols that may be found in this document are defined as follows:

Symbol	Description
 <b>DANGER</b>	Indicates a hazard with a high level of risk which, if not avoided, will result in death or serious injury.
 <b>WARNING</b>	Indicates a hazard with a medium level of risk which, if not avoided, could result in death or serious injury.
 <b>CAUTION</b>	Indicates a hazard with a low level of risk which, if not avoided, could result in minor or moderate injury.
 <b>NOTICE</b>	Indicates a potentially hazardous situation which, if not avoided, could result in equipment damage, data loss, performance deterioration, or unanticipated results. NOTICE is used to address practices not related to personal injury.
 <b>NOTE</b>	Supplements the important information in the main text. NOTE is used to address information not related to personal injury, equipment damage, and environment deterioration.

## Change History

Changes between document issues are cumulative. The latest document issue contains all the changes made in earlier issues.

### Issue 03 (2025-12-20)

Updated [6.6.4 Grid Connection Control](#).

Updated [6.6.5 Microgrid Control](#).

### Issue 02 (2025-09-30)

Updated [4 Electrical Connections](#).

Updated [6 WebUI Operations](#).

Updated [8 Maintenance](#).

### Issue 01 (2025-08-30)

This issue is used for first office application (FOA).

---

# Contents

---

<b>About This Document.....</b>	<b>ii</b>
<b>1 Safety Information.....</b>	<b>1</b>
1.1 Personal Safety.....	2
1.2 Electrical Safety.....	4
1.3 Environment Requirements.....	6
1.4 Mechanical Safety.....	7
<b>2 Product Overview.....</b>	<b>9</b>
2.1 Model.....	9
2.2 Appearance.....	10
2.3 Button.....	12
2.4 Ports.....	13
2.4.1 Optical Ports.....	13
2.4.2 Ethernet Ports.....	14
2.4.3 DI/DO/AI Ports.....	15
2.4.4 COM Ports.....	17
2.4.5 MBUS Port.....	17
2.4.6 4G/SIM Port.....	18
2.4.7 High-Voltage DI/DO Ports.....	19
2.4.8 Current/Voltage Detection Ports.....	21
2.4.9 Power Input/Output Ports.....	22
2.5 Indicators.....	23
2.6 Networking Application.....	24
2.7 Device Storage.....	27
<b>3 Product Installation.....</b>	<b>29</b>
3.1 Installation Requirements.....	29
3.2 Tools.....	30
3.3 Pre-installation Check.....	31
3.4 Installing the Product.....	31
3.5 Installing a Power Adapter.....	33
<b>4 Electrical Connections.....</b>	<b>35</b>
4.1 Preparing Cables.....	35
4.2 Connecting a PE Cable.....	38

4.3 Connecting an MBUS Cable.....	38
4.4 Connecting Fiber Optic Jumpers.....	41
4.5 Connecting an Ethernet Cable.....	42
4.6 Connecting an RS485 Signal Cable.....	43
4.7 Connecting a DI Signal Cable.....	44
4.8 Connecting a DO Signal Cable.....	44
4.9 Connecting an AI Signal Cable.....	45
4.10 Connecting an Output Power Cable.....	46
4.11 Connecting an Input/Output Power Cable.....	46
4.12 Connecting a Current Detection Signal Cable.....	47
4.13 Connecting a Voltage Detection Signal Cable.....	50
4.14 Connecting a High-Voltage DI Signal Cable.....	51
4.15 Connecting a High-Voltage DO Signal Cable.....	51
4.16 Installing a SIM Card and 4G Antenna.....	52
<b>5 Power-On.....</b>	<b>54</b>
<b>6 WebUI Operations.....</b>	<b>56</b>
6.1 Logging In to the WebUI.....	56
6.2 WebUI Overview.....	58
6.3 Overview.....	59
6.4 Monitoring.....	63
6.4.1 Logger.....	63
6.4.2 Inverter.....	64
6.4.3 ESS.....	96
6.4.4 MBUS.....	123
6.4.4.1 MBUS-Inside.....	123
6.4.5 METER.....	125
6.4.5.1 Modbus Meter.....	125
6.4.6 EMI.....	127
6.5 Query.....	128
6.6 Settings.....	130
6.6.1 Date and Time.....	130
6.6.2 Port Settings.....	131
6.6.2.1 WLAN.....	131
6.6.2.2 Mobile Network.....	133
6.6.2.3 Ethernet.....	134
6.6.2.4 RS485.....	135
6.6.2.5 MBUS.....	136
6.6.2.6 AI/DI.....	136
6.6.2.7 PT/CT.....	137
6.6.3 Communications Protocol.....	138
6.6.3.1 Modbus.....	138
6.6.3.2 IEC104.....	143

6.6.3.2.1 General Service.....	143
6.6.3.2.2 Custom Service.....	146
6.6.3.3 GOOSE.....	150
6.6.3.4 HTTPS.....	152
6.6.4 Grid Connection Control.....	152
6.6.4.1 Active Power.....	152
6.6.4.1.1 Unlimited.....	154
6.6.4.1.2 Scheduling via DI.....	154
6.6.4.1.3 Remote Scheduling.....	156
6.6.4.1.4 Limited Feed-in.....	159
6.6.4.1.5 Remote Output Control.....	164
6.6.4.2 Reactive Power.....	166
6.6.4.2.1 No Output.....	168
6.6.4.2.2 Scheduling via DI.....	168
6.6.4.2.3 Fixed Reactive Power.....	170
6.6.4.2.4 Fixed Power Factor.....	171
6.6.4.2.5 Remote Scheduling.....	172
6.6.4.2.6 Power Factor Closed-Loop Control.....	174
6.6.4.2.7 Characteristic Curve.....	175
6.6.4.3 ESS Control.....	178
6.6.4.3.1 No Control.....	179
6.6.4.3.2 Max. Self-Consumption.....	180
6.6.4.3.3 Charge/Discharge Based on Grid Dispatch.....	182
6.6.4.3.4 TOU.....	184
6.6.4.3.5 TOU (Fixed Power).....	189
6.6.4.3.6 Automatic SOC/SOH Calibration.....	191
6.6.4.3.7 Scheduling Mode.....	193
6.6.4.3.8 ESS SOC.....	194
6.6.4.4 Capacity/Demand Control.....	196
6.6.4.4.1 Capacity Limit.....	197
6.6.4.4.2 Demand Limit.....	199
6.6.4.5 Protection at Grid Connection Point.....	200
6.6.4.5.1 Protection Upon Power Exception at Grid Connection Point.....	200
6.6.4.5.2 Shutdown at High Feed-In Power.....	201
6.6.4.6 DRM.....	202
6.6.5 Microgrid Control.....	204
6.6.5.1 General Basic Settings.....	204
6.6.5.2 Scheduling Control.....	209
6.6.5.3 On/Off-Grid Switching.....	218
6.6.5.4 Advanced Control Configuration.....	219
6.6.6 Dry Contact Settings.....	220
6.6.7 License Management.....	222

6.7 Maintenance.....	223
6.7.1 Device Management.....	223
6.7.1.1 Device Access.....	223
6.7.1.2 Device List.....	225
6.7.1.3 Device Update.....	225
6.7.1.4 Device Logs.....	226
6.7.1.5 Startup/Shutdown.....	227
6.7.1.6 Black Start.....	227
6.7.1.7 Data Re-collection.....	228
6.7.1.8 Device Replacement.....	228
6.7.2 Security Management.....	229
6.7.2.1 User Management.....	229
6.7.2.2 Certificate Management.....	230
6.7.2.3 Security Settings.....	231
6.7.2.4 Password Reset.....	233
6.7.3 System Maintenance.....	233
6.7.4 Field Test.....	234
6.7.4.1 Terminal Test.....	234
6.7.4.2 Inspection.....	234
6.7.4.3 Data Check.....	235
6.7.5 Recording Settings.....	236
6.7.6 Communication Record.....	236
6.7.7 Damage Detection.....	237
<b>7 App Operations.....</b>	<b>238</b>
<b>8 Maintenance.....</b>	<b>239</b>
8.1 Routine Maintenance.....	239
8.2 Troubleshooting.....	241
8.3 Alarm List.....	244
8.4 Device Replacement.....	244
8.5 Device Disposal.....	245
<b>9 FAQs.....</b>	<b>246</b>
9.1 How Do I Calculate the Monthly Data Usage of a SIM Card?.....	246
9.2 How Do I Identify the Meter Wiring Direction?.....	248
9.3 What Types of Power Meters Can Be Connected?.....	248
9.4 What Types of EMIs Can be Connected?.....	250
9.5 What Standards Must 4G Antennas Prepared by Customers Meet?.....	251
<b>10 Technical Specifications.....</b>	<b>252</b>
<b>A Port Numbers.....</b>	<b>257</b>
<b>B Management System Domain Names.....</b>	<b>259</b>
<b>C Certificate Management and Maintenance.....</b>	<b>260</b>

---

C.1 Initial Certificate Risk Disclaimer.....	260
C.2 Application Scenarios of Initial Certificates.....	260
<b>D Contact Information.....</b>	<b>262</b>
<b>E Digital Power Customer Service.....</b>	<b>264</b>
<b>F Acronyms and Abbreviations.....</b>	<b>265</b>

# 1 Safety Information

---

## Statement

**Before transporting, storing, installing, operating, using, and/or maintaining the equipment, read this document, strictly follow the instructions provided herein, and follow all the safety instructions on the equipment and in this document.** In this document, "equipment" refers to the products, software, components, spare parts, and/or services related to this document; "the Company" refers to the manufacturer (producer), seller, and/or service provider of the equipment; "you" refers to the entity that transports, stores, installs, operates, uses, and/or maintains the equipment.

The **Danger, Warning, Caution, and Notice** statements described in this document do not cover all the safety precautions. You also need to comply with relevant international, national, or regional standards and industry practices. **The Company shall not be liable for any consequences that may arise due to violations of safety requirements or safety standards concerning the design, production, and usage of the equipment.**

The equipment shall be used in an environment that meets the design specifications. Otherwise, the equipment may be faulty, malfunctioning, or damaged, which is not covered under the warranty. The Company shall not be liable for any property loss, personal injury, or even death caused thereby.

Comply with applicable laws, regulations, standards, and specifications during transportation, storage, installation, operation, use, and maintenance.

Do not perform reverse engineering, decompilation, disassembly, adaptation, implantation, or other derivative operations on the equipment software. Do not study the internal implementation logic of the equipment, obtain the source code of the equipment software, violate intellectual property rights, or disclose any of the performance test results of the equipment software.

**The Company shall not be liable for any of the following circumstances or their consequences:**

- The equipment is damaged due to force majeure such as earthquakes, floods, volcanic eruptions, debris flows, lightning strikes, fires, wars, armed conflicts, typhoons, hurricanes, tornadoes, and other extreme weather conditions.
- The equipment is operated beyond the conditions specified in this document.

- The equipment is installed or used in environments that do not comply with international, national, or regional standards.
- The equipment is installed or used by unqualified personnel.
- You fail to follow the operation instructions and safety precautions on the product and in the document.
- You remove or modify the product or modify the software code without authorization.
- You or a third party authorized by you cause the equipment damage during transportation.
- The equipment is damaged due to storage conditions that do not meet the requirements specified in the product document.
- You fail to prepare materials and tools that comply with local laws, regulations, and related standards.
- The equipment is damaged due to your or a third party's negligence, intentional breach, gross negligence, or improper operations, or other reasons not related to the Company.

## 1.1 Personal Safety

---

 **DANGER**

Ensure that power is off during installation. Do not install or remove a cable with power on. Transient contact between the core of the cable and the conductor will generate electric arcs or sparks, which may cause a fire or personal injury.

---

---

 **DANGER**

Non-standard and improper operations on the energized equipment may cause fire, electric shocks, or explosion, resulting in property damage, personal injury, or even death.

---

---

 **DANGER**

Before operations, remove conductive objects such as watches, bracelets, bangles, rings, and necklaces to prevent electric shocks.

---

---

 **DANGER**

During operations, use dedicated insulated tools to prevent electric shocks or short circuits. The dielectric withstanding voltage level must comply with local laws, regulations, standards, and specifications.

---

**Figure 1-1** Personal protective equipment

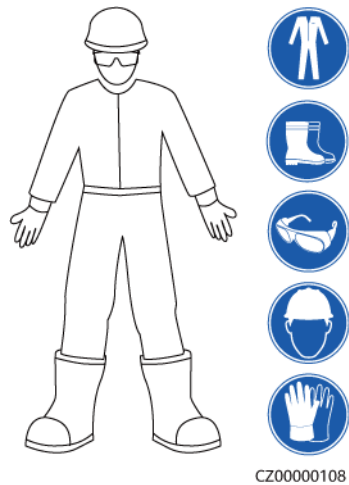

## General Requirements

- Do not stop protective devices. Pay attention to the warnings, cautions, and related precautionary measures in this document and on the equipment.
- If there is a likelihood of personal injury or equipment damage during operations, immediately stop, report the case to the supervisor, and take feasible protective measures.
- Do not power on the equipment before it is installed or confirmed by professionals.
- In the case of a fire, immediately leave the building or the equipment area and activate the fire alarm or call emergency services. Do not enter the affected building or equipment area under any circumstances.

## Personnel Requirements

- Only professionals and trained personnel are allowed to operate the equipment.
  - Professionals: personnel who are familiar with the working principles and structure of the equipment, trained or experienced in equipment operations and are clear of the sources and degree of various potential hazards in equipment installation, operation, maintenance
  - Trained personnel: personnel who are trained in technology and safety, have required experience, are aware of possible hazards on themselves in certain operations, and are able to take protective measures to minimize the hazards on themselves and other people
- Personnel who plan to install or maintain the equipment must receive adequate training, be able to correctly perform all operations, and understand all necessary safety precautions and local relevant standards.
- Only qualified professionals or trained personnel are allowed to install, operate, and maintain the equipment.
- Only qualified professionals are allowed to remove safety facilities and inspect the equipment.
- Personnel who will perform special tasks such as electrical operations, working at heights, and operations of special equipment must possess the required local qualifications.

- Only authorized professionals are allowed to replace the equipment or components (including software).
- Only personnel who need to work on the equipment are allowed to access the equipment.

## 1.2 Electrical Safety

---

 **DANGER**

Non-standard and improper operations may result in fire or electric shocks.

---

---

 **DANGER**

Prevent foreign matter from entering the equipment during operations. Otherwise, equipment short-circuits or damage, load power derating, power failure, or personal injury may occur.

---

---

 **WARNING**

For the equipment that needs to be grounded, install the ground cable first when installing the equipment and remove the ground cable last when removing the equipment.

---

### General Requirements

- Follow the procedures described in the document for installation, operation, and maintenance. Do not reconstruct or alter the equipment, add components, or change the installation sequence without permission.
- Obtain approval from the national or local electric utility company before connecting the equipment to the grid.
- Before installing or removing power cables, turn off the switches of the equipment and its upstream and downstream switches.
- If any liquid is detected inside the equipment, disconnect the power supply immediately and do not use the equipment.
- Before performing operations on the equipment, check that all tools meet the requirements and record the tools. After the operations are complete, collect all of the tools to prevent them from being left inside the equipment.
- Before installing power cables, check that cable labels are correct and cable terminals are insulated.
- When installing the equipment, use a torque tool of a proper measurement range to tighten the screws. When using a wrench to tighten the screws, ensure that the wrench does not tilt and the torque error does not exceed 10% of the specified value.

- If the equipment has multiple inputs, disconnect all the inputs and wait until the equipment is completely powered off before performing operations on the equipment.
- Check equipment connections periodically, ensuring that all screws are securely tightened.
- Only qualified professionals can replace a damaged cable.
- Do not scrawl, damage, or block any labels or nameplates on the equipment. Promptly replace labels that have worn out.
- Do not use solvents such as water, alcohol, or oil to clean electrical components inside or outside of the equipment.

## Grounding

- Ensure that the grounding impedance of the equipment complies with local electrical standards.
- Ensure that the equipment is connected permanently to the protective ground. Before operating the equipment, check its electrical connection to ensure that it is reliably grounded.
- Do not work on the equipment in the absence of a properly installed ground conductor.
- Do not damage the ground conductor.
- For the equipment that uses a three-pin socket, ensure that the ground terminal in the socket is connected to the protective ground point.
- If high touch current may occur on the equipment, ground the protective ground terminal on the equipment enclosure before connecting the power supply; otherwise, electric shock as a result of touch current may occur.

## Cabling Requirements

- When selecting, installing, and routing cables, follow local safety regulations and rules.
- When routing power cables, ensure that there is no coiling or twisting. Do not join or weld power cables. If necessary, use a longer cable.
- Ensure that all cables are properly connected and insulated, and meet specifications.
- Ensure that the slots and holes for routing cables are free from sharp edges, and that the positions where cables are routed through pipes or cable holes are equipped with cushion materials to prevent the cables from being damaged by sharp edges or burrs.
- Ensure that cables of the same type are bound together neatly and straight and that the cable sheath is intact. When routing cables of different types, ensure that they are away from each other without entanglement and overlapping.

## 1.3 Environment Requirements

---

 **DANGER**

Do not expose the equipment to flammable or explosive gas or smoke. Do not perform any operation on the equipment in such environments.

---

---

 **DANGER**

Do not place the equipment near heat sources or fire sources, such as smoke, candles, heaters, or other heating devices. Overheat may damage the equipment or cause a fire.

---

---

 **WARNING**

Install the equipment in an area far away from liquids. Do not install it under areas prone to condensation, such as under water pipes and air exhaust vents, or areas prone to water leakage, such as air conditioner vents, ventilation vents, or feeder windows of the equipment room. Ensure that no liquid enters the equipment to prevent faults or short circuits.

---

### General Requirements

- Ensure that the equipment is stored in a clean, dry, and well ventilated area with proper temperature and humidity and is protected from dust and condensation.
- Keep the installation and operating environments of the equipment within the allowed ranges. Otherwise, its performance and safety will be compromised.
- Do not install, use, or operate outdoor equipment and cables (including but not limited to moving equipment, operating equipment and cables, inserting connectors to or removing connectors from signal ports connected to outdoor facilities, working at heights, performing outdoor installation, and opening doors) in harsh weather conditions such as lightning, rain, snow, and level 6 or stronger wind.
- Do not install the equipment in an environment with direct sunlight, dust, smoke, volatile or corrosive gases, infrared and other radiations, organic solvents, or salty air.
- Do not install the equipment in an environment with conductive metal or magnetic dust.
- Do not install the equipment in an area conducive to the growth of microorganisms such as fungus or mildew.
- Do not install the equipment in an area with strong vibration, noise, or electromagnetic interference.

- After installing the equipment, remove the packing materials such as cartons, foam, plastics, and cable ties from the equipment area.

## 1.4 Mechanical Safety

### DANGER

When working at heights, wear a safety helmet and safety harness or waist belt and fasten it to a solid structure. Do not mount it on an insecure moveable object or metal object with sharp edges. Make sure that the hooks will not slide off.

### WARNING

Ensure that all necessary tools are ready and inspected by a professional organization. Do not use tools that have signs of scratches or fail to pass the inspection or whose inspection validity period has expired. Ensure that the tools are secure and not overloaded.

### WARNING

Do not drill holes into the equipment. Doing so may affect the sealing performance and electromagnetic containment of the equipment and damage components or cables inside. Metal shavings from drilling may short-circuit boards inside the equipment.

## General Requirements

- Do not perform operations such as arc welding and cutting on the equipment without evaluation by the Company.
- Do not install other devices on the top of the equipment without evaluation by the Company.
- Use correct tools and operate them in the correct way.

## Moving Heavy Objects

- Be cautious to prevent injury when moving heavy objects.



< 18 kg  
(< 40 lbs)



18–32 kg  
(40–70 lbs)



32–55 kg  
(70–121 lbs)

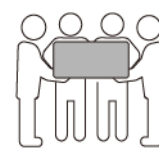

55–68 kg  
(121–150 lbs)



> 68 kg  
(> 150 lbs)

CZ0000110

- If multiple persons need to move a heavy object together, determine the manpower and work division with consideration of height and other conditions to ensure that the weight is equally distributed.

- If two persons or more move a heavy object together, ensure that the object is lifted and landed simultaneously and moved at a uniform pace under the supervision of one person.
- Wear personal protective gears such as protective gloves and shoes when manually moving the equipment.
- To move an object by hand, approach to the object, squat down, and then lift the object gently and stably by the force of the legs instead of your back. Do not lift it suddenly or turn your body around.
- Move or lift the equipment by holding its handles or lower edges. Do not hold the handles of modules that are installed in the equipment.
- Do not quickly lift a heavy object above your waist. Place the object on a workbench that is half-waist high or any other appropriate place, adjust the positions of your palms, and then lift it.
- Move a heavy object stably with balanced force at an even and low speed. Put down the object stably and slowly to prevent any collision or drop from scratching the surface of the equipment or damaging the components and cables.
- When moving a heavy object, be aware of the workbench, slope, staircase, and slippery places. When moving a heavy object through a door, ensure that the door is wide enough to move the object and avoid bumping or injury.
- When transferring a heavy object, move your feet instead of turning your waist around. When lifting and transferring a heavy object, ensure that your feet point to the target direction of movement.

# 2 Product Overview

## 2.1 Model

### Model Number Description

This document involves the following models:

- SmartMGC5000B04NH
- SmartMGC5000B06GL

Figure 2-1 Model number

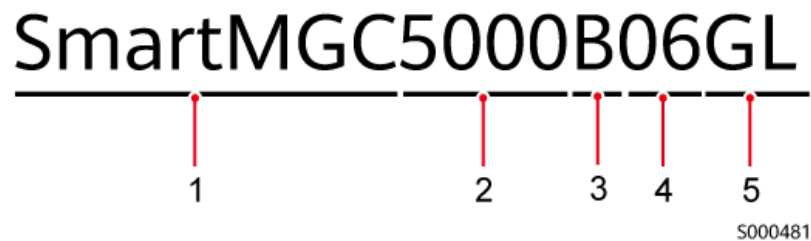

Table 2-1 Model number description

No.	Meaning	Description
1	Product category	SmartMGC (Smart Microgrid Controller)
2	Product generation	5000
3	Application scenario	B: commercial & industrial (C&I)
4	Feature ID	<ul style="list-style-type: none"><li>• 04: 4G+optical port (SFP)</li><li>• 06: 4G+MBUS+optical port (SFP)</li></ul>

No.	Meaning	Description
5	Region	<ul style="list-style-type: none"><li>• GL: Global</li><li>• NH: Japan</li></ul>

## 2.2 Appearance

### Product Dimensions

Figure 2-2 Product dimensions

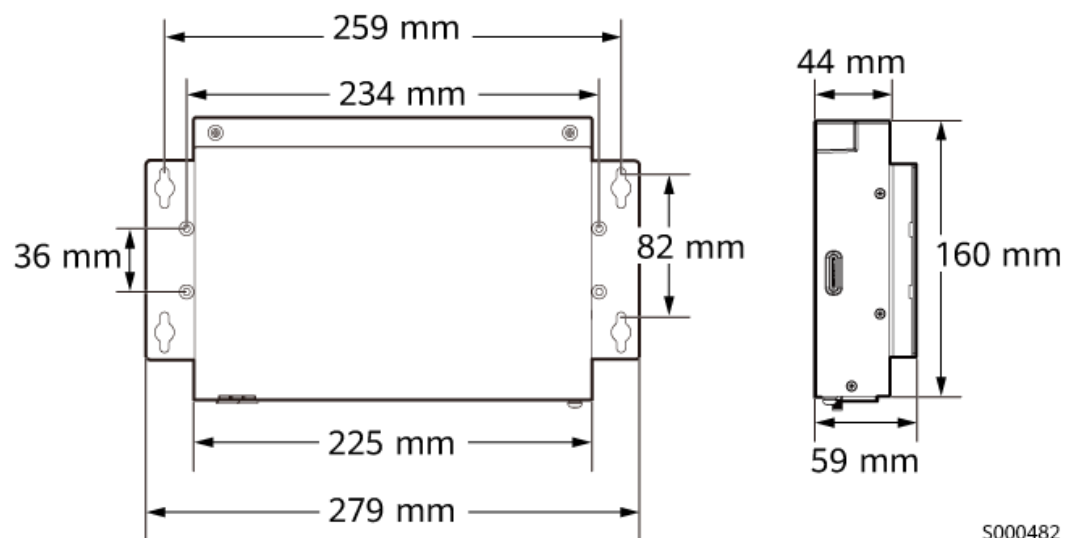

## Appearance

Figure 2-3 Appearance

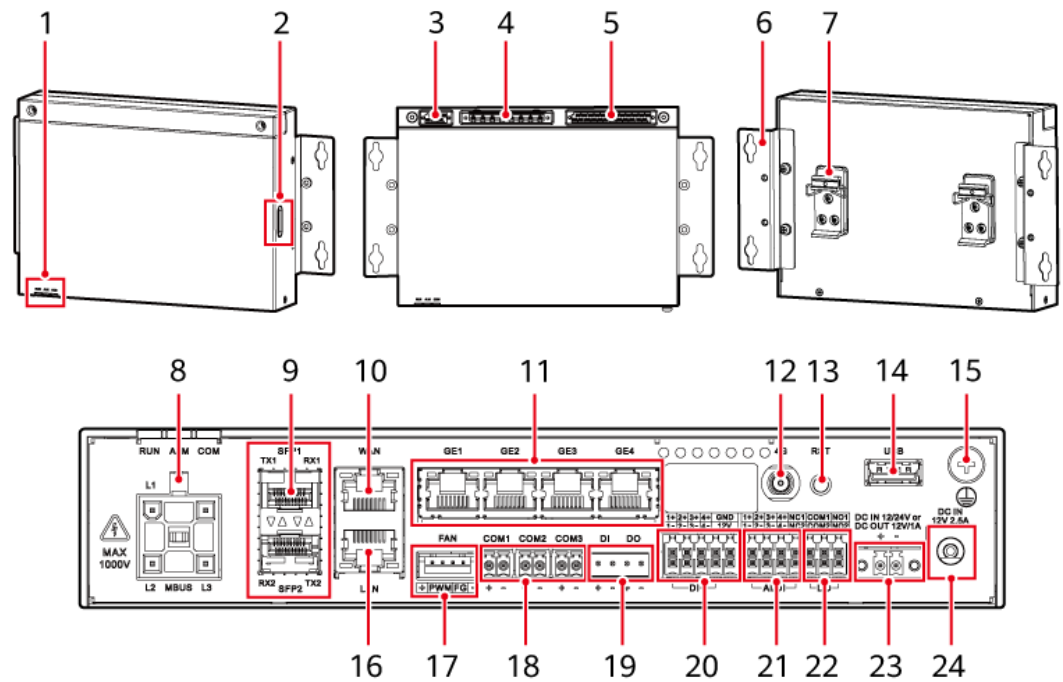







S000499

- |                                 |   |                       |
|---------------------------------|---|-----------------------|
| (1) Indicators                  | (2) SIM card slot                       | (3) I_AC port         |
| (4) U_AC port                   | (5) DO (HV) and DI (HV) ports           | (6) Mounting ear      |
| (7) Guide rail clamp            | (8) MBUS port                           | (9) SFP ports         |
| (10) WAN port                   | (11) GE ports                           | (12) 4G antenna       |
| (13) RST button                 | (14) USB port (reserved)                | (15) PE point         |
| (16) LAN port                   | (17) FAN port                           | (18) COM ports        |
| (19) Active/Standby DI/DO ports | (20) DI port and 12 V power output port | (21) AI/DI port       |
| (22) DO port                    | (23) Power input/output port            | (24) Power input port |

## Label Description

Table 2-2 Label description

Label	Description
	Grounding

Label	Description
	General warning
	Hot surface warning
	High voltage warning
	WEEE directive (product environmental directive).
	China's environmental mark. No hazardous substances will leak into the environment within 50 years from the product's manufacture date.
<b>CAT II</b>	Overvoltage category label. The label specifies the voltage withstand capability and applicable scenario of the electrical equipment.

## 2.3 Button

Table 2-3 RST button

Operation	Function
Hold down the button for 1s to 3s.	<p>The WLAN module is powered on.</p> <ul style="list-style-type: none"> <li>If the <b>O&amp;M policy</b> of WLAN is set to <b>OFF when idle</b>, the WLAN module is powered on. Then, the COM indicator is steady on for 2 minutes (it will restore to the original state 2 minutes later), and the module is waiting for connecting to an app. If not connected to the app, the WLAN module is automatically powered off 4 hours after being powered on.</li> <li>The operation does not take effect if the <b>O&amp;M policy</b> of WLAN is not set to <b>OFF when idle</b>.</li> </ul>
Hold down the button for 10s to 20s.	The device parameter settings are retained, but personal privacy and sensitive data (such as the login password and email address) are cleared.

Operation	Function
Hold down the button for more than 60s.	The default settings are restored. Within 3 minutes after the device is powered on and restarted, press and hold the RST button for more than 60s after the RUN indicator starts to blink fast. The device is restored to default settings and restarts (all the indicators are off). After the restart is successful, the RUN indicator blinks fast again.

 NOTE

The **O&M policy** of WLAN is set to **OFF when idle** by default. To set **O&M policy**, choose **Set > Port Settings > WLAN**.

## 2.4 Ports

### 2.4.1 Optical Ports

The Ethernet optical ports (SFP1 and SFP2) can be connected to 100M/1000M SFP optical modules to implement ring networking using the RSTP or STP protocol.

Figure 2-4 Optical ports

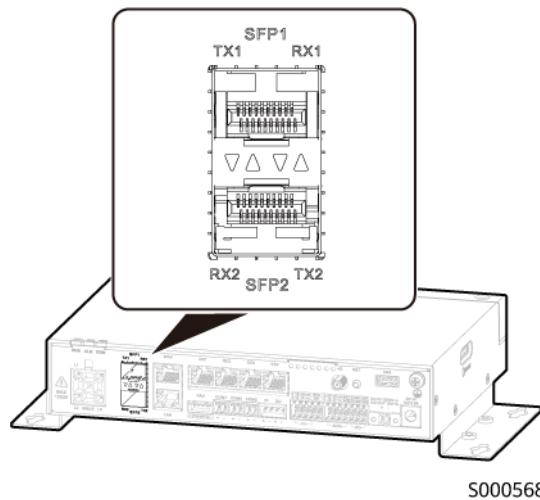

S000568

Port		Description
SFP1	TX1	Supports northbound or southbound ring networking: <ul style="list-style-type: none"> <li>• A northbound ring network supports a maximum of 16 nodes (including the central switch).</li> <li>• If Huawei's devices are connected in a southbound ring network, a maximum of 20 nodes are supported.</li> </ul>
	RX1	
SFP2	RX2	
	TX2	
Indicators	Green indicator	If the green indicator is steady on, the connection is normal.
	Yellow indicator	If the yellow indicator blinks, data communication is normal.

**NOTICE**

The ESS can be connected to the SmartMGC only through the LAN port, GE3/GE4 ring network, or SFP1/SFP2 ring network.

## 2.4.2 Ethernet Ports

The device has one WAN port, one LAN port, and four GE ports. The ports support 10M/100M/1000M auto-negotiation and can be connected to devices such as Ethernet switch or energy storage system (ESS).

Figure 2-5 Ethernet ports

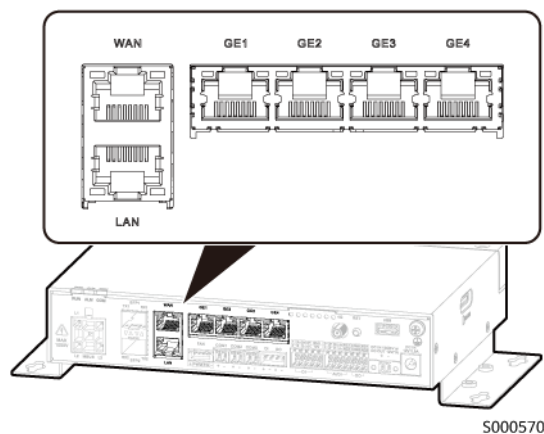

Port	Description
WAN	Connects to the management system in the northbound direction through a device such as an Ethernet switch or a router.

Port		Description
LAN		Connects to a device such as ESS in the southbound direction.
GE1		<ul style="list-style-type: none"> <li>Connects to a device such as Ethernet switch or router in the northbound direction.</li> <li>Connects to a device such as ESS in the southbound direction.</li> <li>Supports southbound ring networking through GE3 and GE4.</li> </ul>
GE2		
GE3		
GE4		
Indicators	Green indicator	If the green indicator is steady on, the connection is normal.
	Yellow indicator	If the yellow indicator blinks, data communication is normal.

**NOTICE**

- The SmartModule can be connected to the SmartMGC only through the LAN port.
- The ESS can be connected to the SmartMGC only through the LAN port, GE3/GE4 ring network, or SFP1/SFP2 ring network.

### 2.4.3 DI/DO/AI Ports

Figure 2-6 DI/DO/AI ports

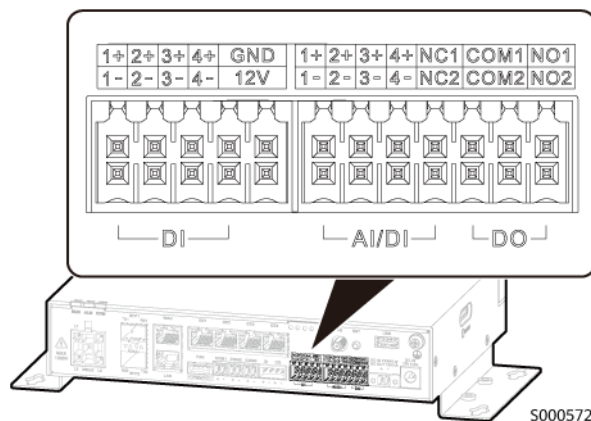

- DI port: digital input, connecting to DI-type power grid scheduling commands or alarm signals.

Port		Description
DI	1+	Receive passive dry contact signals.

Port		Description
	1-	
	2+	
	2-	
	3+	
	3-	
	4+	
	4-	

- DO port: digital output, supporting two relay signal outputs.

Port		Description
DO	NC1	<ul style="list-style-type: none"> <li>• NC/COM: normally closed contact</li> <li>• NO/COM: normally open contact</li> <li>• Supports the 12 V DC signal voltage.</li> </ul>
	COM1	
	NO1	
	NC2	
	COM2	
	NO2	

- AI/DI port: digital or analog input. You can switch the mode (AI mode by default) on the web user interface (WebUI) or app. The AI mode is used to connect to an AI-type environment monitoring sensor, whereas the DI mode is used to connect to DI-type power grid scheduling commands or alarm signals.

Port		Description
AI/DI	1+	<ul style="list-style-type: none"> <li>• AI mode: supports voltage-type AI signal input and 0–10 V voltage input.</li> <li>• DI mode: supports passive dry contact signal input.</li> </ul>
	1-	
	2+	<ul style="list-style-type: none"> <li>• AI mode: supports current-type AI signal input and 0–20 mA or 4–20 mA current input.</li> <li>• DI mode: supports passive dry contact signal input.</li> </ul>
	2-	
	3+	
	3-	
	4+	
	4-	

## 2.4.4 COM Ports

The COM ports are three independent ports for RS485 communication and can be connected to devices that comply with the Modbus RTU or IEC 103 protocol.

Figure 2-7 COM ports

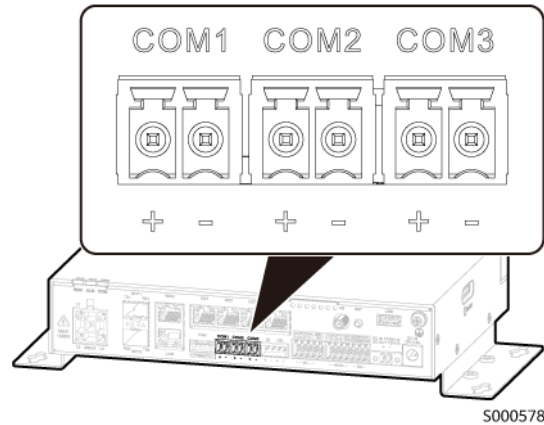

Port		Description
COM1	+	<ul style="list-style-type: none"> <li>Connect to devices such as inverter, smart meter, or environment monitoring instrument (EMI).</li> <li>If inverters need to be connected, it is recommended that each route be connected to a maximum of 30 inverters.</li> </ul>
	-	
COM2	+	
	-	
COM3	+	
	-	

## 2.4.5 MBUS Port

The MBUS port can be connected to an inverter integrating the MBUS function.

Figure 2-8 MBUS port

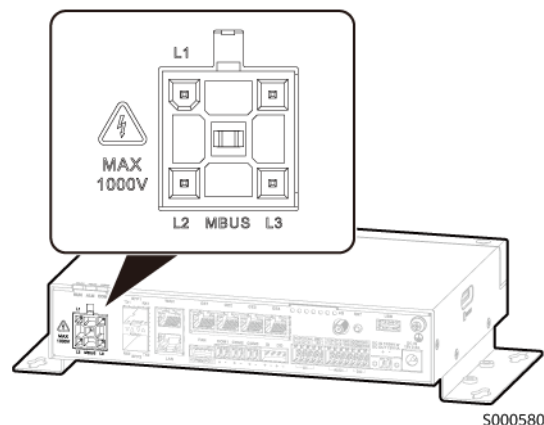

Port		Description
MBUS	L1	<ul style="list-style-type: none"> <li>Supports max. 1000 V AC.</li> <li>Up to 80 inverters can be connected.</li> </ul>
	L2	
	L3	

## 2.4.6 4G/SIM Port

Figure 2-9 4G/SIM port

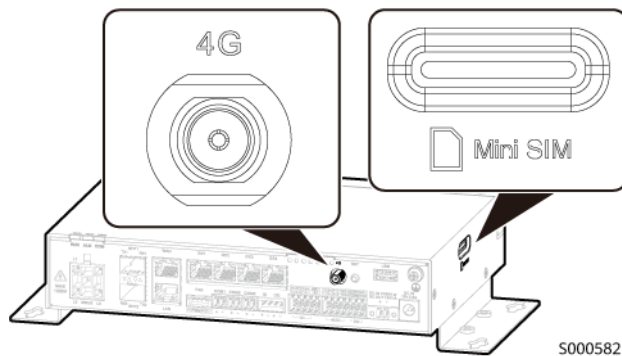

- 4G port: The SmartMGC provides the 4G wireless communication function.

Port	Description
4G	Connects to a 4G antenna.

- SIM card slot: Insert a SIM card of the local carrier to enable dial-up Internet access.

Port	Description
Mini SIM	Supports standard industrial SIM cards (size: 25 mm x 15 mm; capacity: ≥ 64 KB).

## 2.4.7 High-Voltage DI/DO Ports

Figure 2-10 High-voltage DI/DO ports

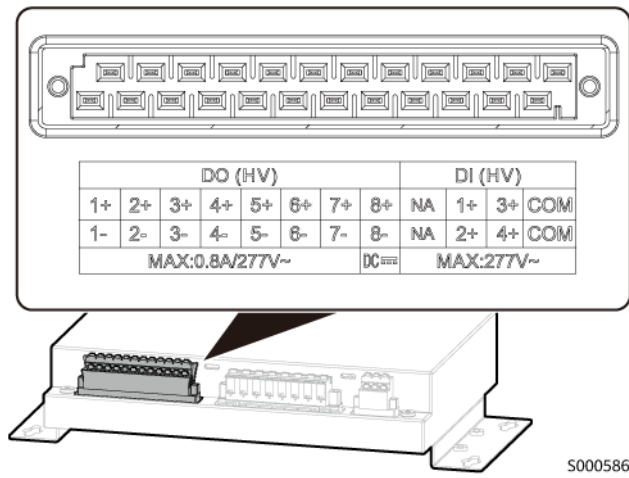

- DO (HV) port: high-voltage digital output

Port		Description
DO (HV)	1+	<ul style="list-style-type: none"> <li>● AC: 100–277 V</li> <li>● DC: 12–30 V</li> <li>● On/Off-grid:                             <ul style="list-style-type: none"> <li>- DO4 (HV): turns off the switch at the grid connection point (common port); supports the DC or AC power supply.</li> <li>- DO5 (HV): starts the genset, or starts the genset at high level.</li> <li>- DO6 (HV): shuts down the genset, or starts the genset at low level.</li> <li>- DO7 (HV): turns on the switch at the grid connection point.</li> </ul> </li> <li>● Off-grid:                             <ul style="list-style-type: none"> <li>- DO1 (HV): turns on the critical load switch.</li> <li>- DO2 (HV): turns off the critical load switch.</li> <li>- DO3 (HV): turns on the minor load switch or the transfer switch.</li> <li>- DO4 (HV): turns off the minor load switch or the transfer switch.</li> <li>- DO5 (HV): turns on the general load switch, starts the genset (control mode: pulse), or (when closed) starts the genset at high level (control mode: level).</li> <li>- DO6 (HV): turns off the general load switch, shuts down the genset (control mode: pulse), or (when open) starts the genset at low level (control mode: level).</li> </ul> </li> </ul>
	1-	
	2+	
	2-	
	3+	
	3-	
	4+	
	4-	
	5+	
	5-	
	6+	
	6-	
	7+	
	7-	
8+	<ul style="list-style-type: none"> <li>● DC: 12–220 V</li> <li>● On/Off-grid:                             <ul style="list-style-type: none"> <li>DO8 (HV): turns off the switch at the grid connection point (fast port); needs to connect to the DC power supply.</li> </ul> </li> </ul> <p><b>NOTE</b> If the working voltage of the I/O control circuit of the switch at the grid connection point is AC, this port must be used together with DO4.</p>	
8-		

- DI (HV) port: high-voltage digital input

Port		Description
DI (HV)	1+	<ul style="list-style-type: none"> <li>AC: 100–277 V</li> <li>DC: 110 V/220 V</li> <li>On/Off-grid:                             <ul style="list-style-type: none"> <li>DI1 (HV): reports the Off state of the grid switch.</li> <li>DI2 (HV): reports the Off state of the genset switch.</li> <li>DI3(HV): reports the state of grid power recovery.</li> <li>DI4 (HV): reports the Off state of the switch at the grid connection point.</li> </ul> </li> <li>Off-grid:                             <ul style="list-style-type: none"> <li>DI1 (HV): reports the Off state of the critical load switch.</li> <li>DI2 (HV): reports the Off state of the minor load switch.</li> <li>DI3 (HV): reports the Off state of the common load switch.</li> <li>DI4 (HV): reports the Off state of the transfer switch.</li> </ul> </li> </ul>
	2+	
	3+	
	4+	
	COM	
	COM	

## 2.4.8 Current/Voltage Detection Ports

Figure 2-11 Current/voltage detection ports

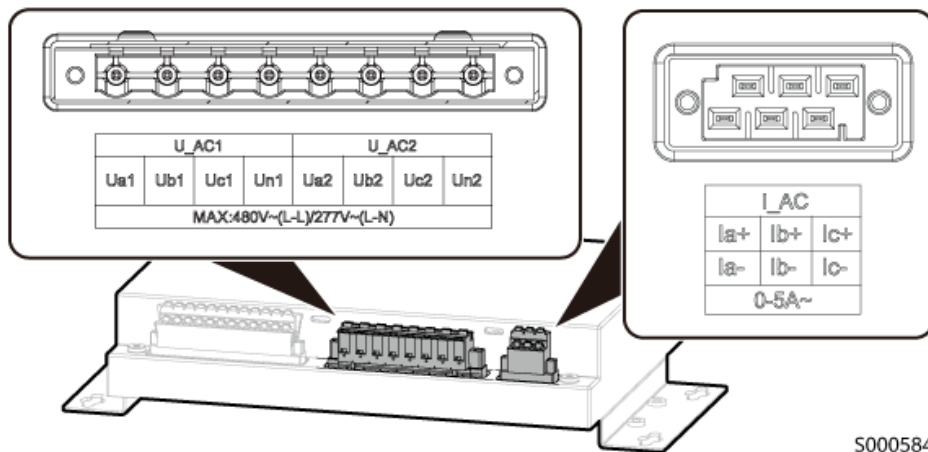

S000584

- I\_AC: current detection

Port		Description
I_AC	Ia+	Detects three routes of current in one group; connects to a current transformer (with a rated current of 5 A on the secondary side). It is recommended that a current transformer with an accuracy class of 0.5 or higher be used. (If the accuracy class is lower than 0.5, the detection precision of the system will be compromised.)
	Ia-	
	Ib+	
	Ib-	
	Ic+	
	Ic-	

- U\_AC port: detects voltage. Three-phase three-wire or three-phase four-wire connection is supported.

Port		Description
U_AC1	Ua1	Detects three routes of voltage in two groups; connects to a potential transformer (with a rated voltage of 100 V on the secondary side) or directly connects to a voltage (Uan/Ubn/Ucn: 57.7–277 V; Uab/Ubc/Uac: 100–480 V).
	Ub1	
	Uc1	
	Un1	
U_AC2	Ua2	
	Ub2	
	Uc2	
	Un2	

## 2.4.9 Power Input/Output Ports

Figure 2-12 Power input/output ports

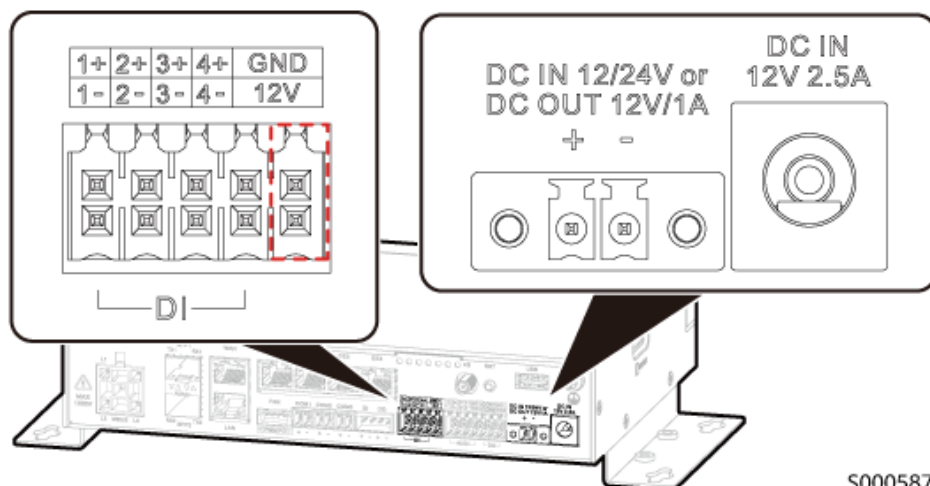

S000587

- 12 V power output port: drives the coil of the intermediate relay (select an intermediate relay with a freewheeling diode for the coil; otherwise, the device may be damaged) for feed-in limitation or audible and visual alarming.

Port	Description
GND	The maximum output current is 0.1 A.
12V	

- Power input port: DC 2.0 input port, which is connected to the power adapter.

Port	Description
DC IN 12V 2.5A	Supports 12 V DC/2.5 A power input.

- Power input/output port: The port can be used as either a power input or output port.

Port		Description
DC IN 12/24V or DC OUT 12V/1A	+	<ul style="list-style-type: none"> <li>• Supports 24 V DC 0.8 A power input and 12 V DC 1.5 A power input.</li> <li>• Supports 12 V DC/1 A power output.</li> </ul>
	-	

## 2.5 Indicators

Figure 2-13 Indicators

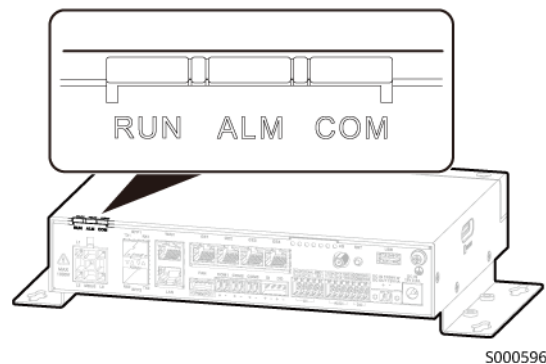

**Table 2-4** Indicator description

Indicator	Status	Description
RUN indicator	Off	The device is not powered on.
	Blinking fast (on for 0.125s and then off for 0.125s)	The device is not registered with the management system or has failed to communicate with the management system.
	Blinking slowly (on for 1s and then off for 1s)	The communication with the management system is normal.
ALM indicator	Off	The system has not raised an alarm.
	Steady on	The system has raised a major alarm.
	Blinking fast (on for 0.5s and then off for 0.5s)	The system has raised a minor alarm.
	Blinking slowly (on for 1s and then off for 4s)	The system has raised a warning.
COM indicator	Steady on	The WLAN module is manually activated locally and is waiting for connecting to an app.
	Off	The 4G networking function is disabled.
	Blinking fast (on for 0.125s and then off for 0.125s)	The 4G network is not registered or 4G communication is interrupted.
	Blinking slowly (on for 1s and then off for 1s)	The 4G communication is normal.

## 2.6 Networking Application

### Functions

The SmartMGC (Logger for short) monitors and manages PV systems and ESSs. It converges all ports, converts protocols, collects and stores data, and centrally monitors and maintains the devices in the systems.

### Networking Scenarios

#### NOTE

The ESS can be connected to the SmartMGC only through the LAN port, GE3/GE4 ring network, or SFP1/SFP2 ring network.

Figure 2-14 Fiber ring network

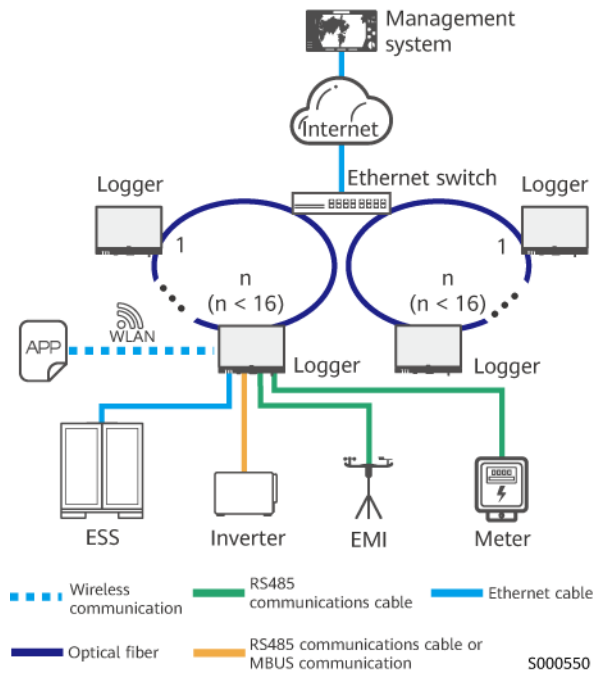

**NOTE**

- The switch must support and enable the standard RSTP, and the bridge priority of the switch must be higher than 0x8000 of the SmartMGC (recommended value: 0x7000; a smaller value indicates a higher bridge priority). For details about how to configure the RSTP and bridge priority of the switch, contact the vendor. If the switch does not support the RSTP, the fiber ring topology must be changed to a chain or star topology.
- If the SmartMGC is connected to an Ethernet switch using a fiber optic cable (single-mode), the communication distance is less than or equal to 12 km (if a 100M optical module is used) or less than or equal to 10 km (if a 1000M optical module is used).

**Figure 2-15** Fiber star network

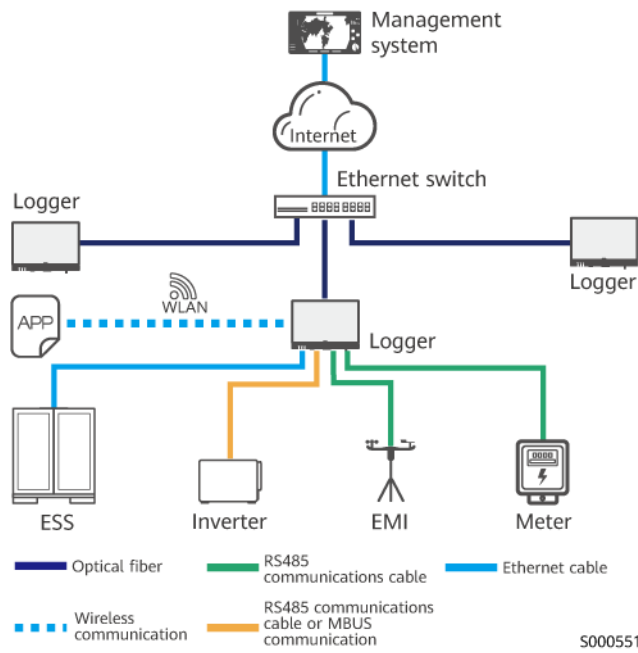

**NOTE**

If the SmartMGC is connected to an Ethernet switch using a fiber optic cable (single-mode), the communication distance is less than or equal to 12 km (if a 100M optical module is used) or less than or equal to 10 km (if a 1000M optical module is used).

**Figure 2-16** Ethernet star network

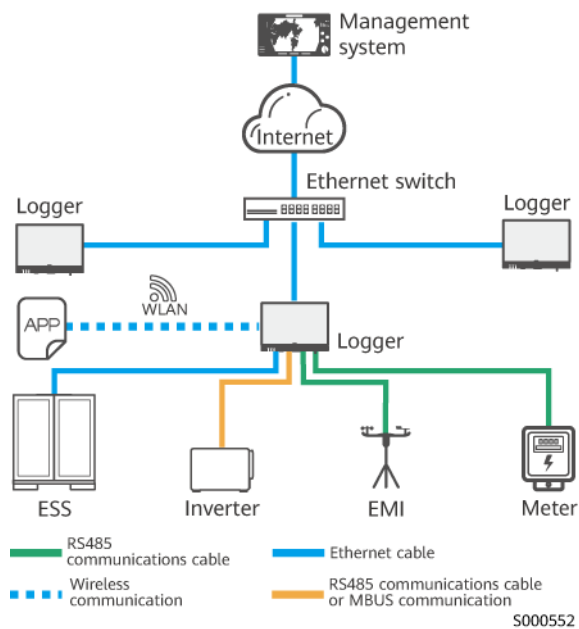

**NOTE**

If the SmartMGC is connected to an Ethernet switch using an Ethernet cable, the communication distance is less than or equal to 100 m.

Figure 2-17 4G network

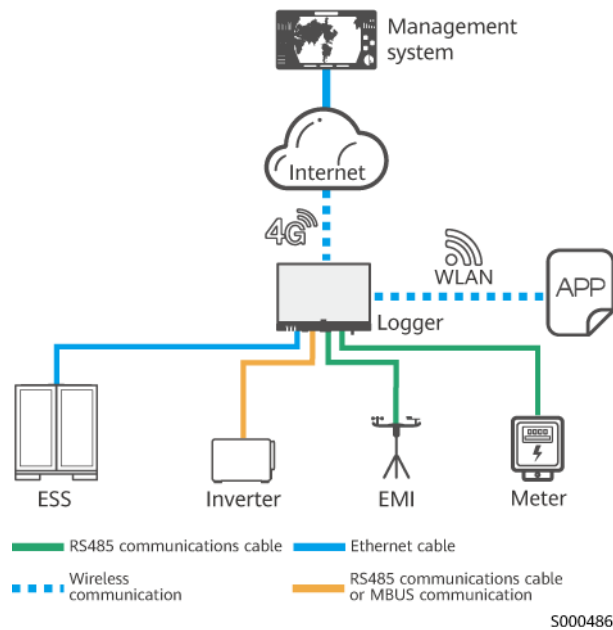

## 2.7 Device Storage

### NOTICE

Store devices according to requirements. Device damage caused by unqualified storage conditions is not covered under the warranty.

If devices will not be put into use immediately, store them according to the requirements specified in this section. Device damage caused by unqualified storage conditions is not covered under the warranty.

- Do not store the devices without outer packaging.
- Do not tilt a packing case or place it upside down.
- Do not remove the outer packaging. Check the packaging regularly (recommended: once every three months). You are advised to remove the outer packaging within 24 hours before installing the device.
- Devices must be stored in a clean and dry environment with appropriate temperature and humidity. The air must not contain corrosive or flammable gases.

**Figure 2-18** Storage temperature and humidity

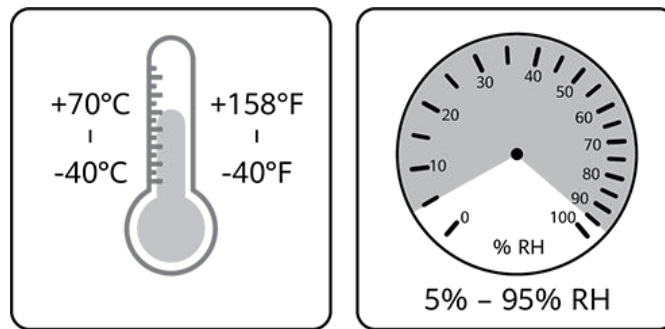

IS07W00011

- When temporarily storing devices outdoors, do not stack them on a pallet. Take rainproof measures such as using tarpaulins to protect devices from rain and water.
- Do not store devices for more than two years. If devices have been stored for two years or longer, they must be checked and tested by professionals before being put into use.

# 3 Product Installation

## 3.1 Installation Requirements

### NOTICE

- Do not install the product in areas with flammable and explosive materials and direct sunlight.
- The product should be installed at an appropriate height to facilitate operations and maintenance.
- If the product is not used in the way specified by the manufacturer, the protection provided by the equipment may be damaged.



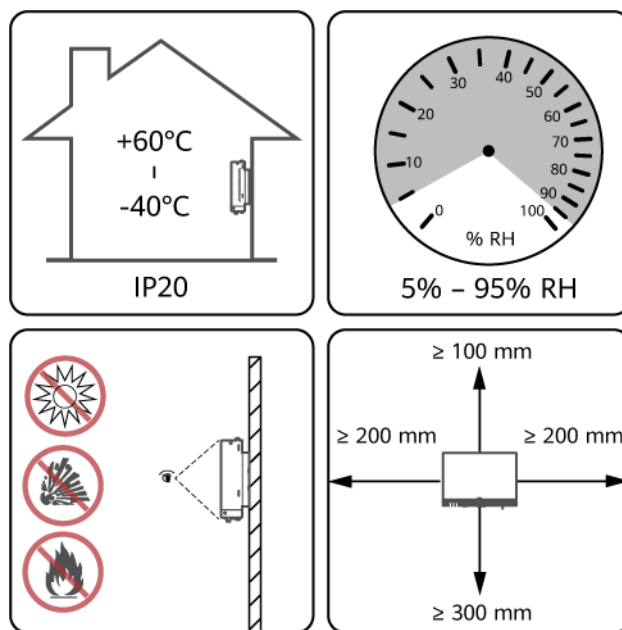

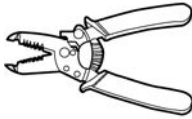

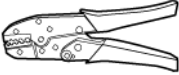
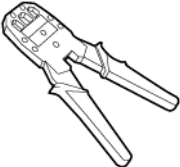

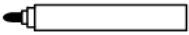
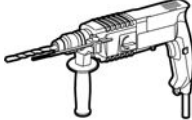









Figure 3-1 Installation position requirements









5000488

## 3.2 Tools

**Table 3-1** Installation tools

Installation Tools			
  <p>Phillips torque screwdriver (M4/ST3.5)</p>	  <p>Flat-head torque screwdriver (Φ2 mm/Φ2.5 mm)</p>	 <p>Wire stripper</p>	 <p>Cable cutter</p>
 <p>Crimping tool</p>	 <p>RJ45 crimping tool</p>	 <p>Heat gun</p>	 <p>Heat shrink tubing</p>
 <p>Marker</p>	 <p>Hammer drill</p>	 <p>Hammer drill bit (Φ6 mm)</p>	 <p>Rubber mallet</p>
 <p>Network tester</p>	 <p>Multimeter</p>	 <p>Cable tie</p>	 <p>Level</p>
 <p>Steel measuring tape</p>	 <p>Vacuum cleaner</p>	 <p>Optical fiber tester (laser pointer)</p>	-

**Table 3-2** Personal protective equipment (PPE)

PPE			
			
Insulated gloves	Safety goggles	Dust mask	Insulated shoes
		-	-
Safety helmet	Reflective vest		

 **NOTE**

- The tool pictures are for reference only.
- This section may not list out some tools required onsite. Onsite installation personnel and the customer need to prepare the tools based on site requirements.

### 3.3 Pre-installation Check

**Table 3-3** Pre-installation check

Check Item	Criteria
Outer packaging	The outer packaging is intact and tidy. If it is damaged or abnormal, do not unpack it, and contact your vendor.
Deliverables	Check the number of deliverables against the packing list in the packing case. If any deliverables are missing or damaged, contact your vendor.

### 3.4 Installing the Product

The SmartMGC can be installed using screws or a guide rail.

## Installation Using Screws

### WARNING

- You are advised to use the tapping screws and expansion tubes delivered with the product.
- When mounting the SmartMGC, ensure that the network port faces downward for easy cable connection and maintenance.

Figure 3-2 Installation using screws

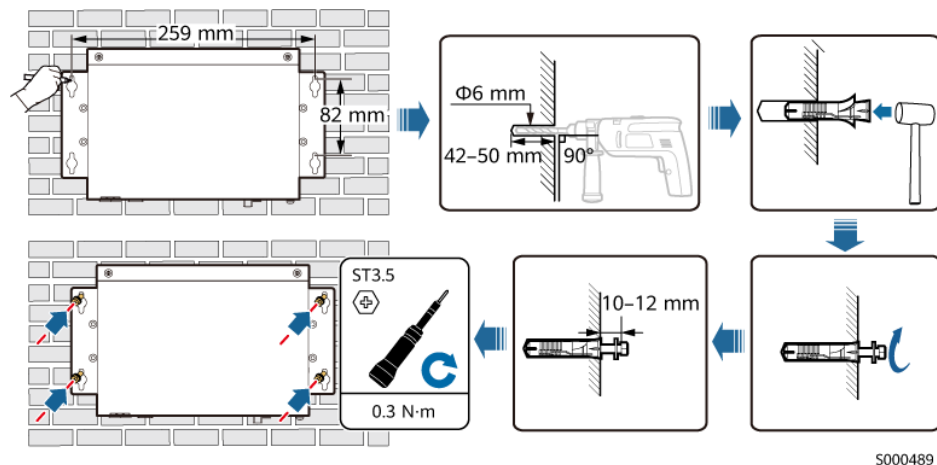

S000489

## Installation on a Guide Rail

### NOTICE

- You need to prepare a 35 mm standard guide rail. The recommended effective length is greater than or equal to 230 mm.
- When mounting the SmartMGC on the guide rail, ensure that the cable connection area faces downward for easy cable connection and maintenance.

Figure 3-3 Installation on a guide rail

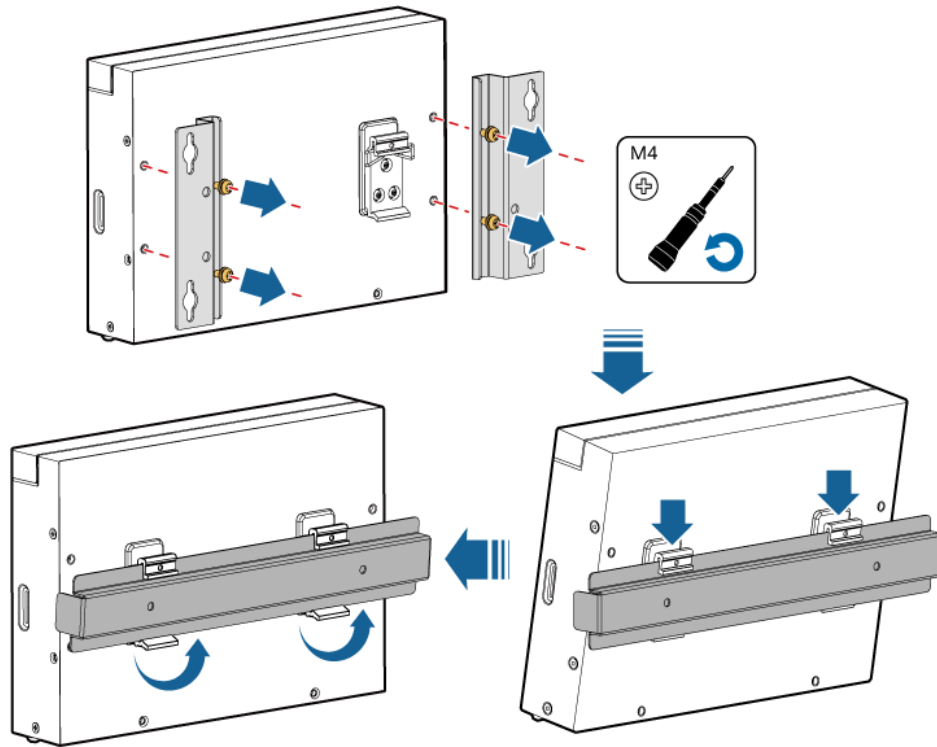

## 3.5 Installing a Power Adapter

Install a power adapter if the SmartMGC requires it. The following to describe how to install a power adapter using screws.

### Installation Using Screws

---

**WARNING**

- You are advised to use the tapping screws and expansion tubes delivered with the product.
  - It is recommended that the power adapter be installed on the right side of the SmartMGC. Keep the AC power cable port upward.
-

Figure 3-4 Installation using screws (method 1)

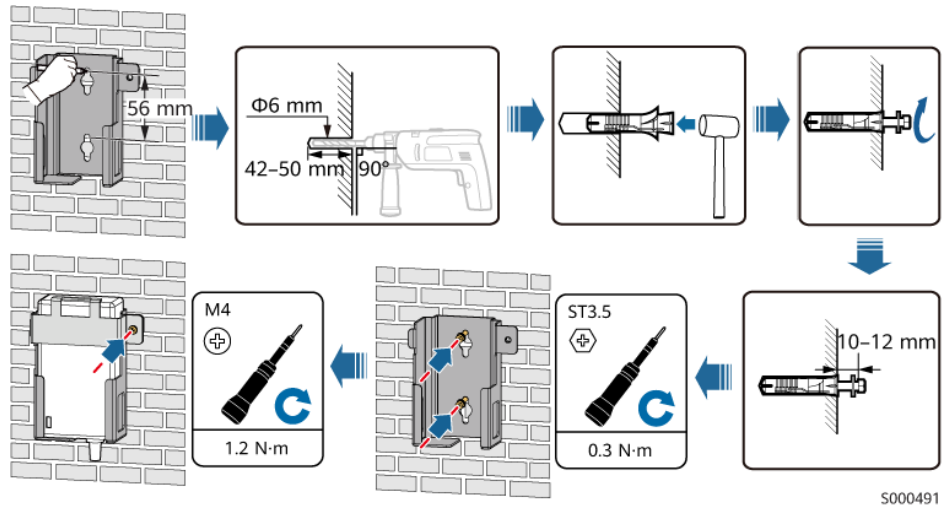
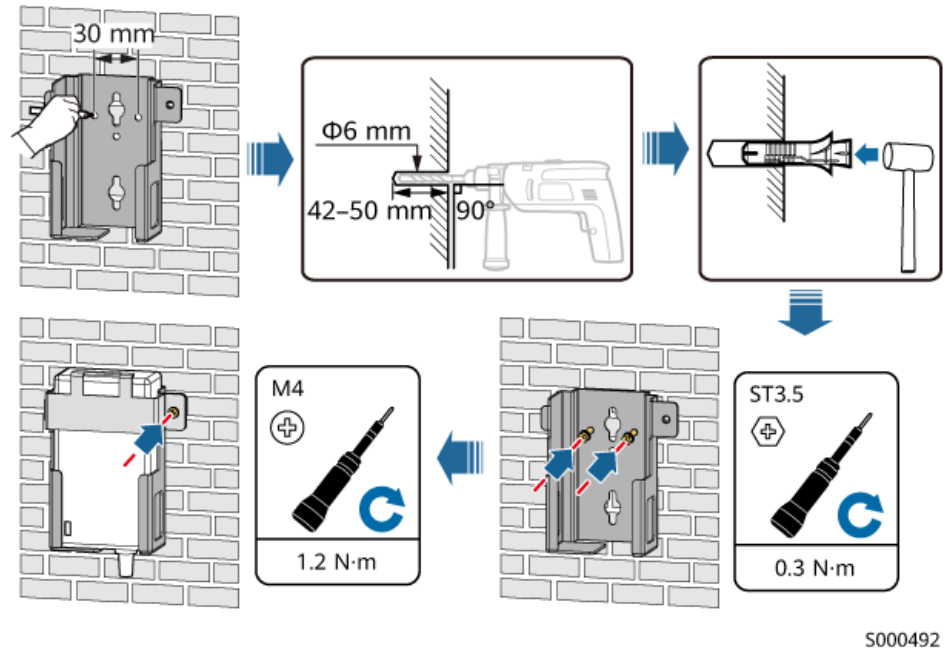

Figure 3-5 Installation using screws (method 2)



# 4 Electrical Connections

## NOTICE

- When connecting cables, see [2.4 Ports](#) to confirm the specifications of each port and the devices to be connected.
- The cable colors shown in cable connection schematic diagrams are for reference only. Select cables according to local cable specifications.
- Avoid scratching the wire core when stripping a cable. Ensure that the stripping length is appropriate so that the stripped wire core can be completely inserted during cable connection.

## 4.1 Preparing Cables

Figure 4-1 Cables

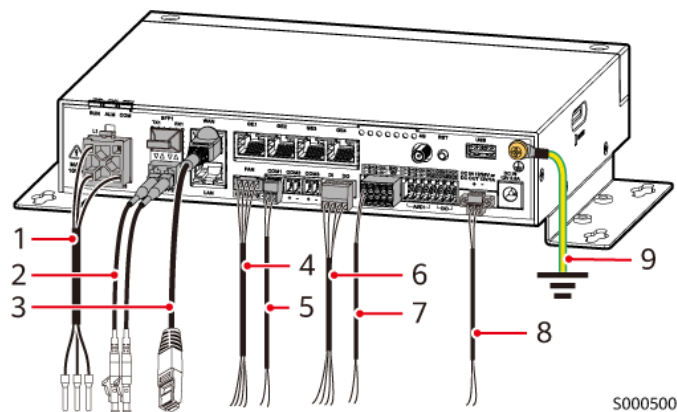
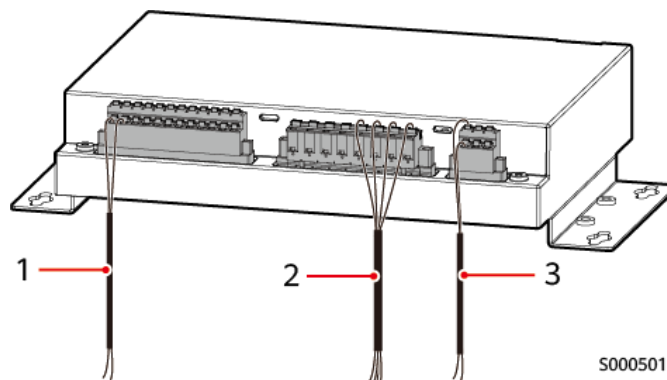

Table 4-1 Cable description

No.	Cable	Type	Cable Specifications	Remarks
1	MBUS cable	Multi-core cable	1.5 m long	Delivered with the product

No.	Cable	Type	Cable Specifications	Remarks
2	Optical cable	Armored optical cable	Single-mode optical fiber (pigtail connector: LC)	Prepared by the customer
3	Ethernet cable	Shielded network cable	Cat 5e or higher (RJ45 connector)	Prepared by the customer
4	FAN signal cable	Multi-core cable	Cross-sectional area: 0.2–0.5 mm <sup>2</sup>	Configured for the fan
5	RS485 signal cable	Outdoor shielded twisted pair cable (Do not use a network cable as a substitute.)	Cross-sectional area: 0.2–2.5 mm <sup>2</sup>	Prepared by the customer
6	Active/ Standby DI/DO signal cable	Multi-core cable	Cross-sectional area: 0.2–1.5 mm <sup>2</sup>	Prepared by the customer
7	DI/DO/AI signal cable	Multi-core cable	Cross-sectional area: 0.2–1.5 mm <sup>2</sup>	Prepared by the customer
8	Power cable	Multi-core cable	Cross-sectional area: 0.2–1.5 mm <sup>2</sup>	Prepared by the customer
9	PE cable	Outdoor copper cable	Cross-sectional area: 4–6 mm <sup>2</sup>	Prepared by the customer

Figure 4-2 Cables

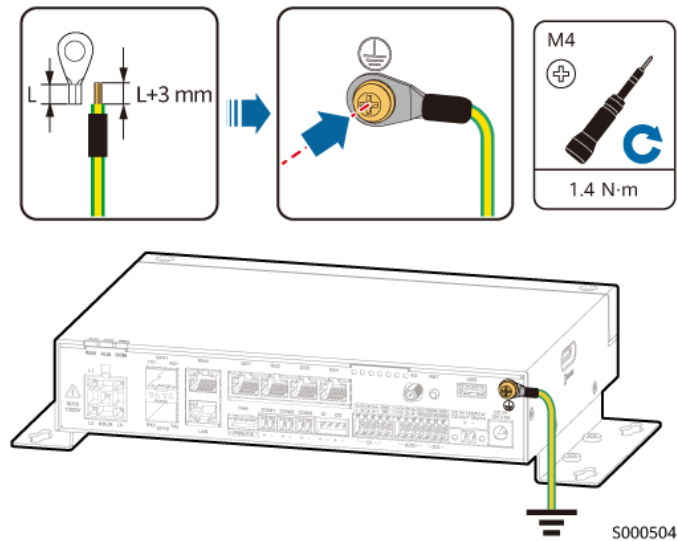

**Table 4-2** Cable description

No.	Cable	Type	Cable Specifications	Remarks
1	High-voltage DI/DO signal cable	Multi-core cable	Cross-sectional area: 0.2–1.5 mm <sup>2</sup> (It is recommended that cord end terminals that match the wire size be used. Otherwise, poor contact may occur. If cord end terminals are used, select a cable with a cross-sectional area of 0.25–1 mm <sup>2</sup> .)	Prepared by the customer
2	Voltage detection signal cable	Copper cable	Cross-sectional area: 0.2–2.5 mm <sup>2</sup> (It is recommended that cord end terminals that match the wire size be used. Otherwise, poor contact may occur. If cord end terminals are used, select a cable with a cross-sectional area of 0.25–1.5 mm <sup>2</sup> .)	Prepared by the customer
3	Current detection signal cable	Copper cable	Cross-sectional area: 0.2–1.5 mm <sup>2</sup> (It is recommended that cord end terminals that match the wire size be used. Otherwise, poor contact may occur. If cord end terminals are used, select a cable with a cross-sectional area of 0.25–1 mm <sup>2</sup> .)	Prepared by the customer

## 4.2 Connecting a PE Cable

Figure 4-3 Connecting a PE cable



## 4.3 Connecting an MBUS Cable

If the SmartMGC and the inverter support MBUS communication, the SmartMGC can be connected to the inverter through an AC power cable.

---

**⚠ DANGER**

When connecting a high-voltage cable, ensure that the cores are completely inserted into the terminals. Any exposed core will cause fatal hazards.

---

**NOTICE**

- A multi-core cable with a cross-sectional area of 4–16 mm<sup>2</sup> is recommended.
- If a multi-core cable is used, it is recommended that the signal transmission distance be less than or equal to 500 m. For other application methods and corresponding communication distances, contact technical support.
- If the SmartMGC uses an AC power cable for communication, a miniature circuit breaker (MCB) or fuse switch disconnecter need to be installed to prevent device damage in the case of short circuits.
- The MBUS communication is applicable to medium-voltage grid connection scenarios and non-low-voltage public grid connection scenarios (industrial environment). The device must be connected to a dedicated step-up transformer or isolation transformer instead of connecting to low-voltage overhead power lines. The total rated power must be > 75 kW. The distance between the device and the residential area shall be > 30 m.
- If the inverter uses both MBUS and RS485 communications, choose **Set > Port Settings > RS485** and set **Protocol Type** to **Modbus-Control** for the corresponding COM port. If this step is not performed, the power grid dispatching function will be affected.

**Figure 4-4** Cable illustration

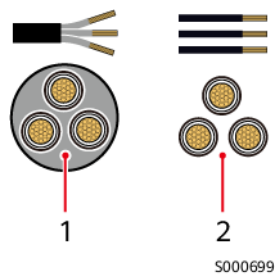

- (1) Multi-core cable (phases A, B, and C within one cable)      (2) Single-core cable (one cable for each of phases A, B, and C)

**Figure 4-5 MBUS networking**

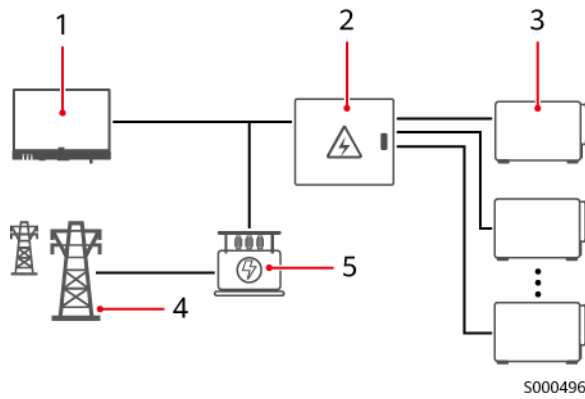

- |                |                           |              |
|----------------|---------------------------|--------------|
| (1) SmartMGC   | (2) AC combiner box       | (3) Inverter |
| (4) Power grid | (5) Isolation transformer | -            |

**Figure 4-6 Connecting an MBUS cable**

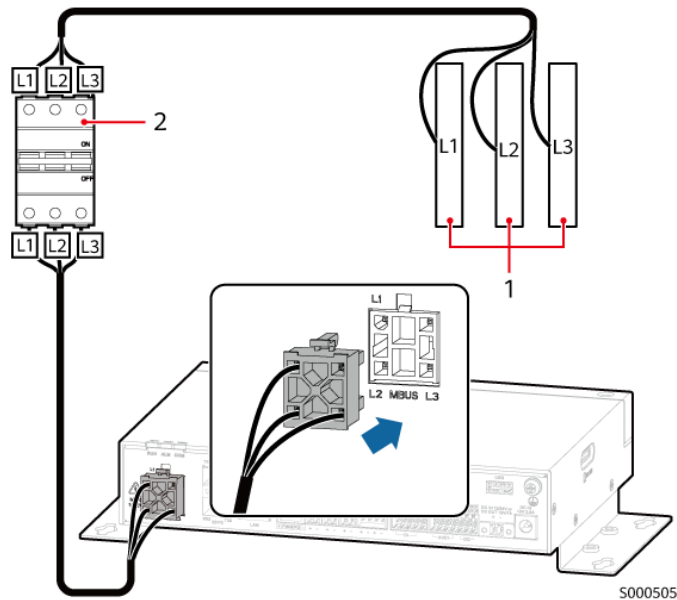

- |            |   |
|------------|---|
| (1) Busbar | (2) Fuse switch disconnector or MCB<br>(6–10 A) |
|------------|---|

**NOTE**

- The rated voltage of the preceding components must match the rated voltage of the system.
- Phases A, B, and C must be respectively connected to L1, L2, and L3.

## 4.4 Connecting Fiber Optic Jumpers

### NOTICE

- You need to configure optical modules by yourself. Select 100M or 1000M SFP optical modules based on the optical switch ports to be connected. A 100M optical module (using single-mode optical fibers) supports a transmission distance of less than or equal to 12 km, whereas a 1000M optical module (using single-mode optical fibers) supports a transmission distance of less than or equal to 10 km.
- The label of the optical module on the SFP1 port faces upwards, whereas the label of the optical module on the SFP2 port faces downwards.
- In dual-plane redundancy networking, both SFP1 and SFP2 can be connected to the northbound monitoring system (IEC104) of the SmartMGC.
- Fiber optic jumper port: LC

Figure 4-7 Connecting fiber optic jumpers

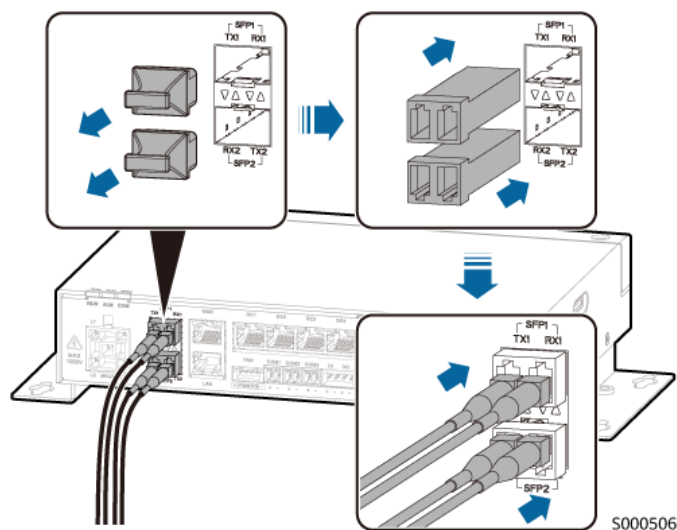

### NOTE

If an armored optical cable needs to be grounded, you are advised to connect it to a ground point nearby.

## 4.5 Connecting an Ethernet Cable

### NOTICE

- It is recommended that the signal transmission distance be less than or equal to 100 m.
- When crimping the network cable, ensure that the shielding layer of the cable is securely connected to the metal shell of the RJ45 connectors.

**Figure 4-8** Connecting an Ethernet cable

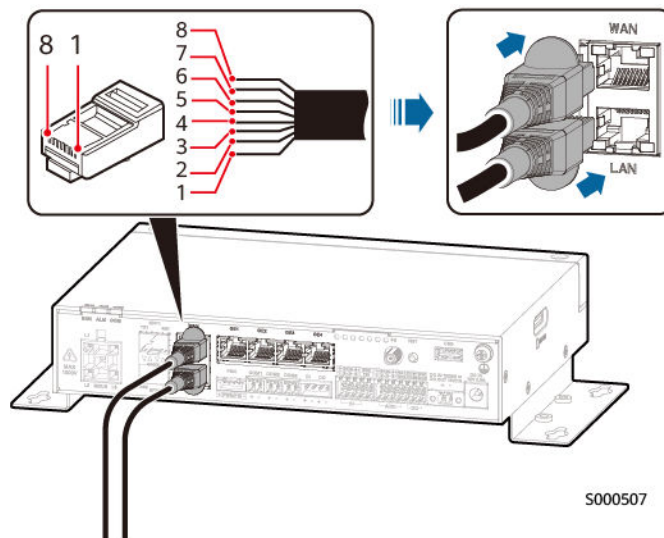

(1) White-and-orange

(2) Orange

(3) White-and-green

(4) Blue

(5) White-and-blue (6) Green

(7) White-and-brown

(8) Brown

## 4.6 Connecting an RS485 Signal Cable

### NOTICE

- Transmission distance:
  - Baud rate 9600 bit/s:  $\leq 1000$  m
  - Baud rate 38,400 bit/s:  $\leq 500$  m
- You are advised to connect fewer than 30 devices to each RS485 route.
- The power meter needs to be connected over a separate RS485 communication line and is not connected to other devices in series.
- The RS485 communications cable must be a shielded twisted pair, and the shield layer must be grounded (you are advised to connect it to a ground point nearby).
- The baud rate, communications protocol, and parity mode of all devices on an RS485 cascading link must be the same as those of the COM port.
- When connecting cables, ensure that RS485+ (RS485A) is connected to COM+ of the SmartMGC and RS485- (RS485B) is connected to COM- of the SmartMGC.

**Figure 4-9** Connecting an RS485 signal cable

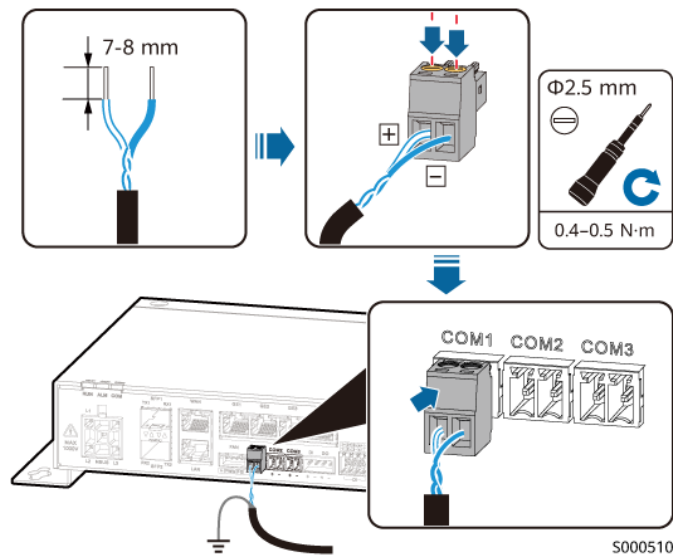
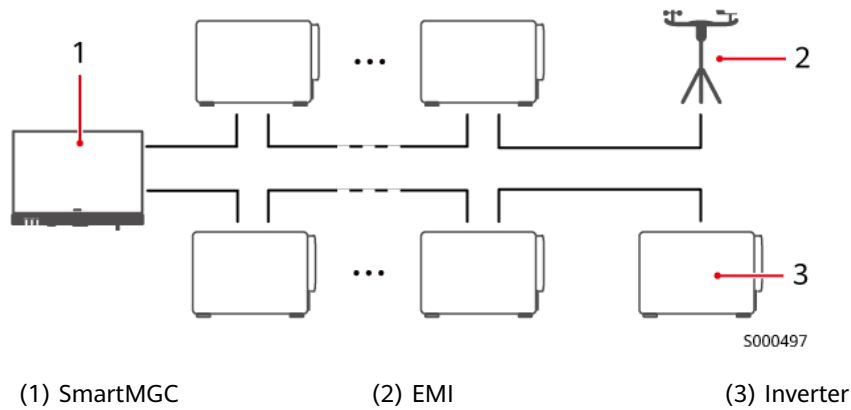

Figure 4-10 Cascading connection



## 4.7 Connecting a DI Signal Cable

### NOTICE

It is recommended that the signal transmission distance be less than or equal to 10 m.

Figure 4-11 Connecting a DI signal cable

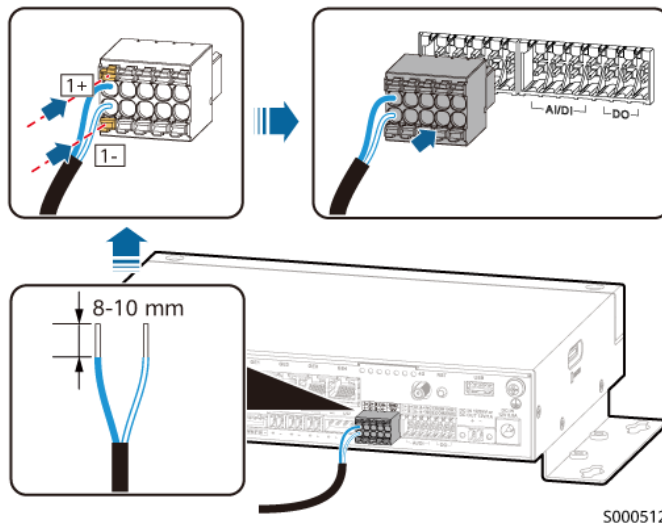

## 4.8 Connecting a DO Signal Cable

### NOTICE

It is recommended that the signal transmission distance be less than or equal to 10 m.

Figure 4-12 Connecting a DO signal cable

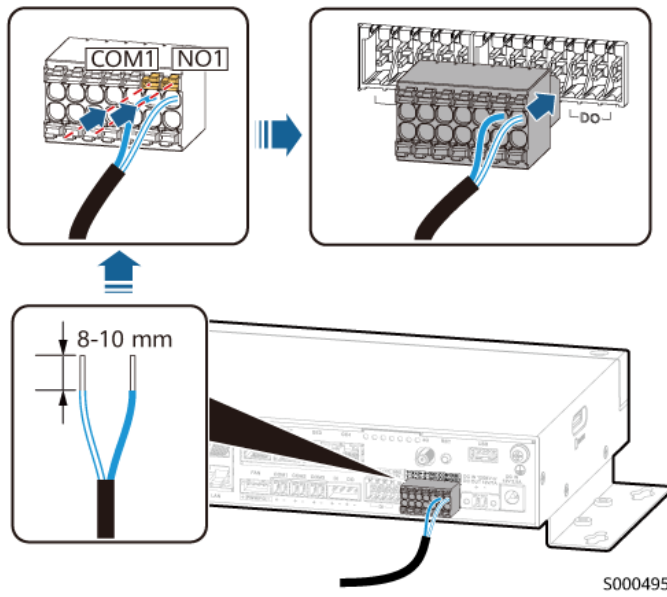

## 4.9 Connecting an AI Signal Cable

### NOTICE

It is recommended that the signal transmission distance be less than or equal to 10 m.

Figure 4-13 Connecting an AI signal cable

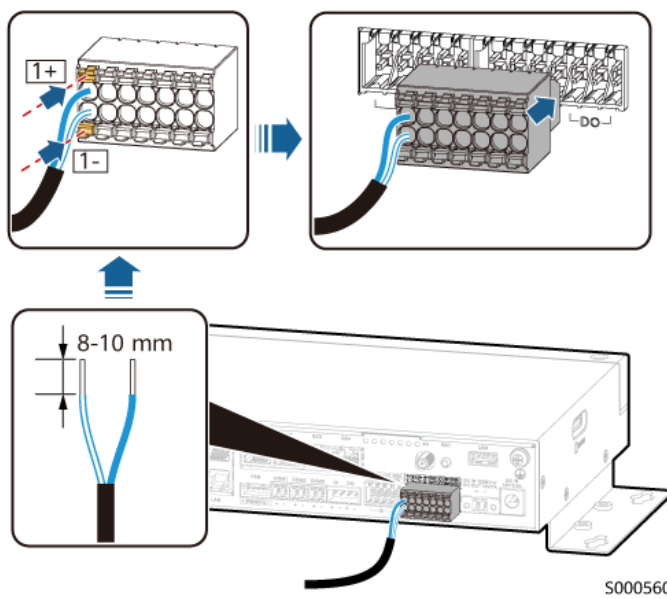

## 4.10 Connecting an Output Power Cable

The SmartMGC drives the coil of the intermediate relay through the 12 V output power port and the DO port for feed-in limitation or audible and visual alarming.

### NOTICE

It is recommended that the signal transmission distance be less than or equal to 10 m.

**Figure 4-14** Connecting an output power cable

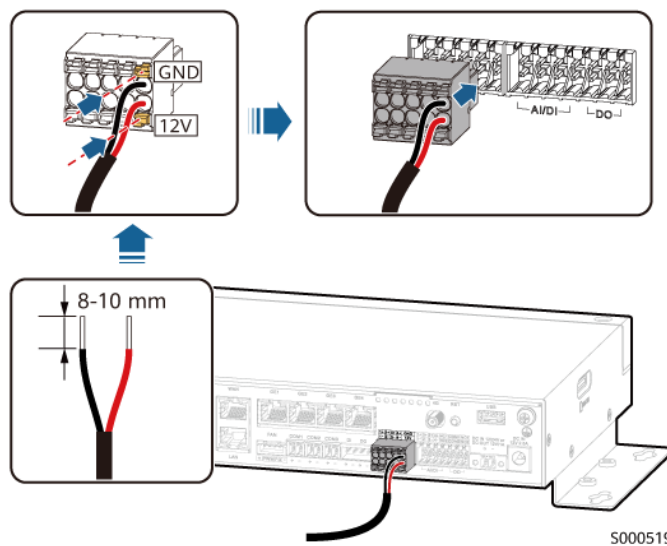

## 4.11 Connecting an Input/Output Power Cable

### NOTICE

- It is recommended that the signal transmission distance be less than or equal to 3 m.
- When the SmartMGC is connected to the power supply through a power adapter, this port can be used as a power output port to supply power to a device.

**Figure 4-15** Connecting an input/output power cable

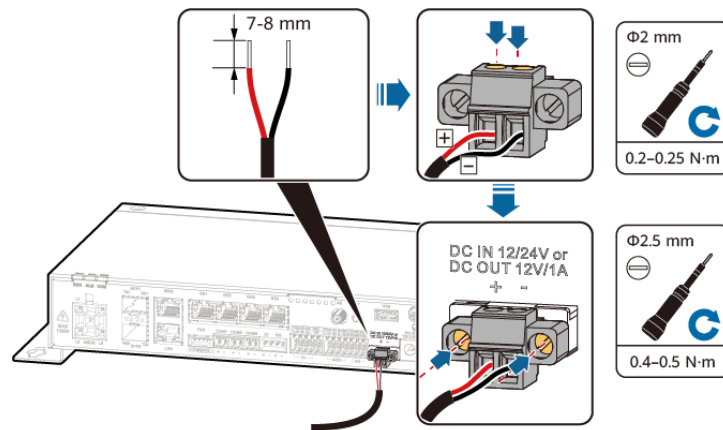

S000514

## 4.12 Connecting a Current Detection Signal Cable

### **⚠ DANGER**

- Ensure that the secondary side has no open circuit for the current transformer (CT) in operation and no short circuit for the potential transformer (PT) in operation. Otherwise, overcurrent or high voltage may occur, which may cause equipment damage and personal injury or even death.
- Before connecting a current detection signal cable, power off the primary circuit of the CT.
- When connecting a high-voltage cable, ensure that the cores are completely inserted into the terminals. Any exposed core will cause fatal hazards.

### **NOTICE**

- For three-phase three-wire connection, phase B does not need to connect to a CT.
- It is recommended that the signal transmission distance be  $\leq 5$  m. For other application scenarios, contact technical support.
- Before replacing the SmartMGC or maintaining the CT loop, ensure that the CT loop is powered off and the jumper bar of the CT loop is correctly connected.
- It is recommended that the cross-sectional area of the cable connected to the secondary side of the CT be  $\geq 1.5$  mm<sup>2</sup>. If a terminal block is available, it is recommended that the cross-sectional area of the cable between the secondary side of the CT and the terminal block be  $\geq 2.5$  mm<sup>2</sup>.

**NOTE**

- Remove the protective cover from the port before connecting the signal cable. You do not need to reinstall the protective cover after the cable is connected.
- It is recommended that cord end terminals be used. Select cord end terminals that match the wire size. Otherwise, poor contact may occur.

**Figure 4-16** Wiring diagram (three-phase three-wire)

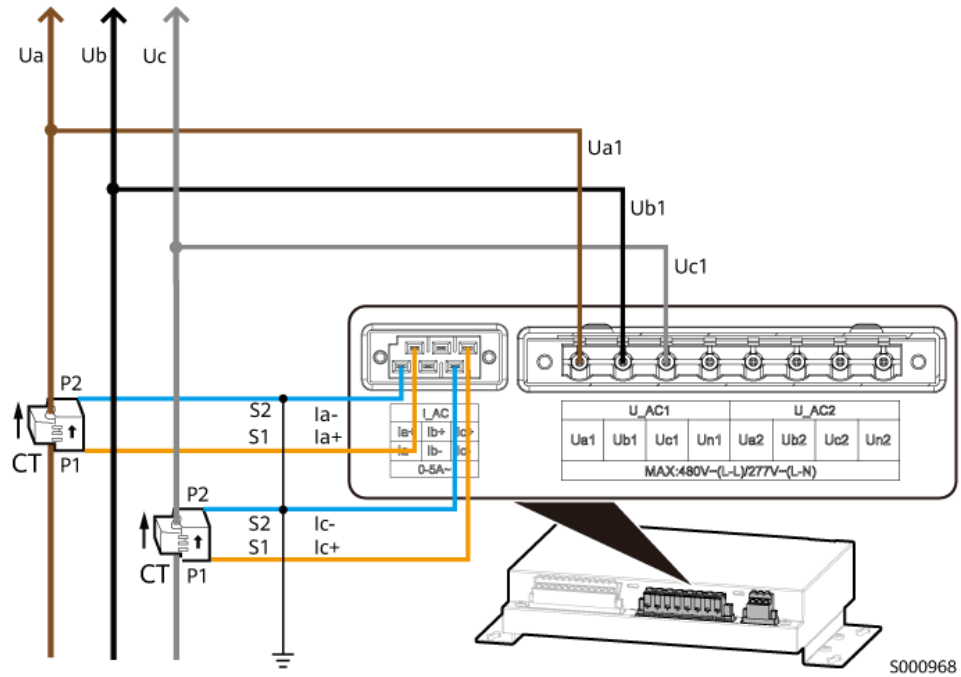

**Figure 4-17** Wiring diagram (three-phase four-wire)

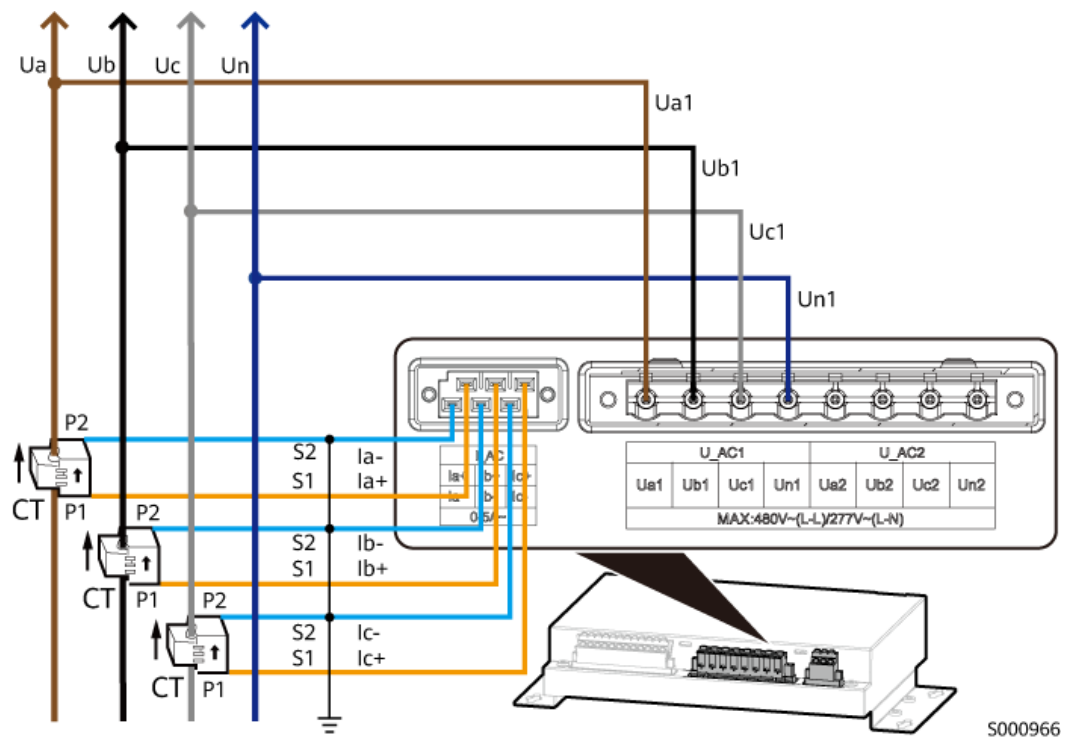

**Figure 4-18** Connecting a current detection signal cable

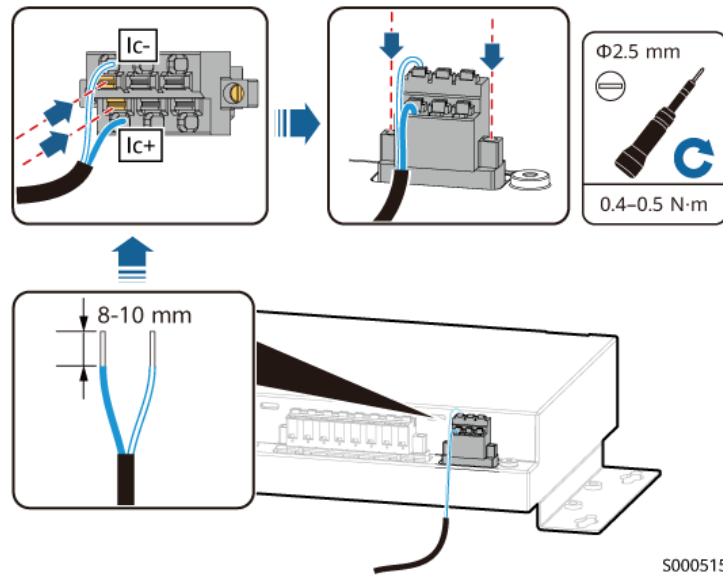

## Selection of CT Secondary Capacity (VA)

**Table 4-3** Selection of CT secondary capacity (VA) (current sampling level: 5 A)

Cable Length	Cable Cross-Sectional Area	CT Rated Load (VA)
1 m	1.5 mm <sup>2</sup>	> 3.62
	2.5 mm <sup>2</sup>	> 3.37
5 m	1.5 mm <sup>2</sup>	> 6.08
	2.5 mm <sup>2</sup>	> 4.85
10 m	1.5 mm <sup>2</sup>	> 9.15
	2.5 mm <sup>2</sup>	> 6.7
50 m	1.5 mm <sup>2</sup>	> 33.75
	2.5 mm <sup>2</sup>	> 21.5
100 m	1.5 mm <sup>2</sup>	> 64.5
	2.5 mm <sup>2</sup>	> 40

 NOTE

- For other application scenarios, contact technical support.
- Example:
  - If the cable length is 5 m and the cable cross-sectional area is 1.5 mm<sup>2</sup>, the rated load of the CT must be > 6.08 VA. A 10 VA CT is recommended.
  - If the cable length is 5 m and the cable cross-sectional area is 2.5 mm<sup>2</sup>, the rated load of the CT must be > 4.85 VA. A 5 VA CT is recommended.

## 4.13 Connecting a Voltage Detection Signal Cable

 DANGER

- Ensure that the secondary side has no open circuit for the CT in operation and no short circuit for the PT in operation. Otherwise, overcurrent or high voltage may occur, which may cause equipment damage and personal injury or even death.
- When connecting a high-voltage cable, ensure that the cores are completely inserted into the terminals. Any exposed core will cause fatal hazards.

NOTICE

It is recommended that the signal transmission distance be less than or equal to 50 m.

 NOTE

- Remove the protective cover from the port before connecting the signal cable. You do not need to reinstall the protective cover after the cable is connected.
- It is recommended that cord end terminals be used. Select cord end terminals that match the wire size. Otherwise, poor contact may occur.

Figure 4-19 Connecting a voltage detection signal cable

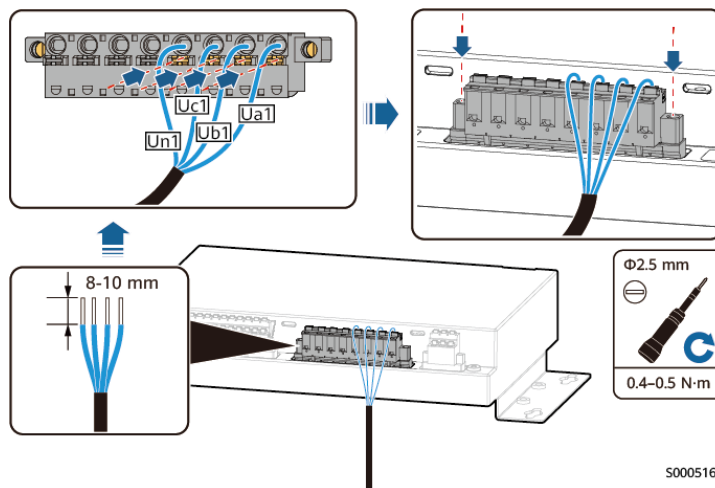

## 4.14 Connecting a High-Voltage DI Signal Cable

### DANGER

When connecting a high-voltage cable, ensure that the cores are completely inserted into the terminals. Any exposed core will cause fatal hazards.

### NOTICE

It is recommended that the signal transmission distance be less than or equal to 50 m.

### NOTE

- Remove the protective cover from the port before connecting the signal cable. You do not need to reinstall the protective cover after the cable is connected.
- It is recommended that cord end terminals be used. Select cord end terminals that match the wire size. Otherwise, poor contact may occur.

Figure 4-20 Connecting a high-voltage DI signal cable

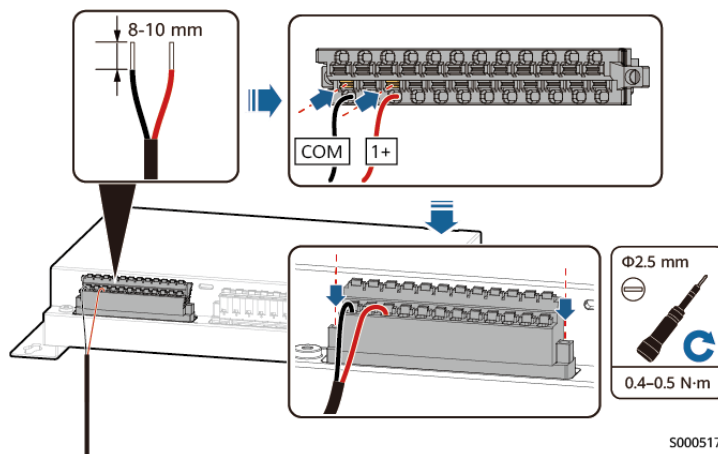

## 4.15 Connecting a High-Voltage DO Signal Cable

### DANGER

When connecting a high-voltage cable, ensure that the cores are completely inserted into the terminals. Any exposed core will cause fatal hazards.

**NOTICE**

It is recommended that the signal transmission distance be less than or equal to 50 m.

**NOTE**

- Remove the protective cover from the port before connecting the signal cable. You do not need to reinstall the protective cover after the cable is connected.
- It is recommended that cord end terminals be used. Select cord end terminals that match the wire size. Otherwise, poor contact may occur.

**Figure 4-21** Connecting a high-voltage DO signal cable

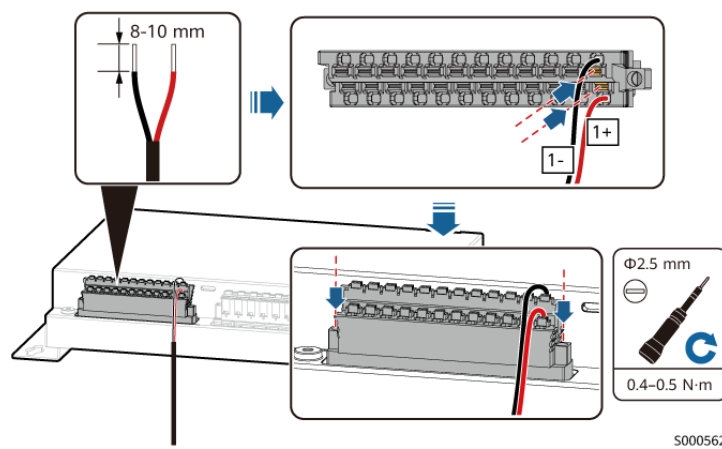

## 4.16 Installing a SIM Card and 4G Antenna

**NOTICE**

- You need to prepare an industrial SIM card.
- Determine the SIM card installation direction based on the silk screen.
- Press the SIM card in place to lock it. In this case, the SIM card is correctly installed.
- When removing the SIM card, push it inwards to eject it.
- If the SIM card is not registered, the total data plan will be limited. You can configure a fixed domain name for dedicated data usage. For details, contact the carrier of your SIM card.
- If the SIM card size is not 25 mm x 15 mm, do not insert it into the SIM card slot. A card holder of the correct size must be used.
- You can prepare an antenna by referring to [9.5 What Standards Must 4G Antennas Prepared by Customers Meet?](#)

**Figure 4-22** Installing a SIM card and 4G antenna

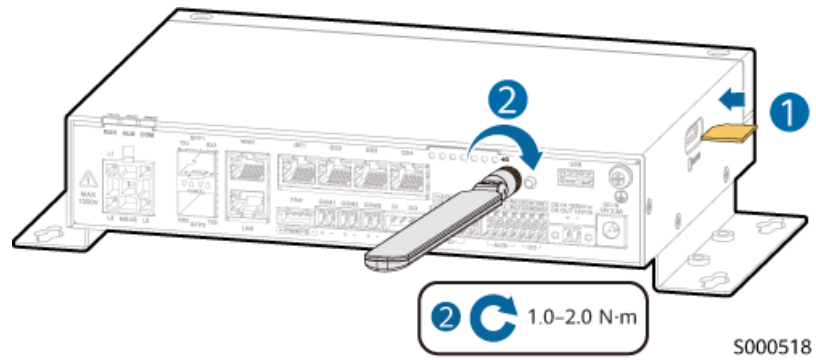

# 5 Power-On

## Check Before Power-On

No.	Expected Result
1	The product is installed correctly and securely.
2	All cables are connected securely. Cables comply with the cable routing requirements and cable routing plan.
3	Cables are bound neatly, and cable ties are spaced evenly, secured properly, and face the same direction. There are no unnecessary adhesive tapes or cable ties on cables.

## Powering On the Product

- Method 1: Use a power adapter. Connect the power adapter cable and insert the plug into the socket.

### NOTE

The rated input voltage of the power adapter must range from 100 V AC to 240 V AC, and the rated input frequency must be 50 Hz/60 Hz. Select a socket that matches the power adapter.

**Figure 5-1** Power supply through a power adapter

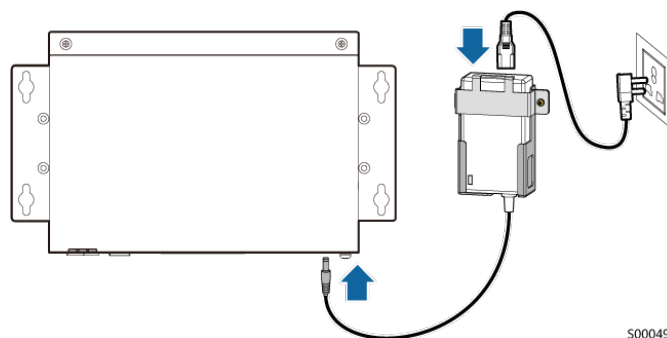

S000494

- Method 2: Use a DC power supply. Check that the input power cables of the SmartMGC are correctly connected (for details, see [4.11 Connecting an](#)

**Input/Output Power Cable**), and turn on the upstream power switch of the DC power supply.

 **NOTE**

When MBUS is used for communication, turn on all the upstream switches of the MBUS port.

# 6 WebUI Operations

## 6.1 Logging In to the WebUI

### Prerequisites

- The operating system of Windows 7 or later is supported.
- An account can be used to log in to only one device at a time. An IP address can be used to log in with only one account at a time. A maximum of two different accounts can be used to log in to the WebUI concurrently.
- You can use Chrome 135, Firefox 137, or a later version to log in. If you use other browsers or versions to log in, functions may be abnormal or cannot be used properly.
- When the same IP address and browser are used to log in to the SmartLogger3000 and SmartMGC5000, you need to clear all browser caches between two logins. Otherwise, the system may be abnormal, affecting normal use.

### Procedure

- Step 1** Connect any network port of the PC to the network port of the SmartMGC using a network cable.
- Step 2** Set the IP address for the PC on the same network segment as the SmartMGC IP address.

Connected Port	IP Setting	Default Value	PC Setting Example
LAN port	IP address	192.168.8.10	192.168.8.11
	Default gateway	192.168.8.1	192.168.8.1
	Subnet mask	255.255.255.0	255.255.255.0
WAN port	IP address	192.168.0.10	192.168.0.11

Connected Port	IP Setting	Default Value	PC Setting Example
	Default gateway	192.168.0.1	192.168.0.1
	Subnet mask	255.255.255.0	255.255.255.0
GE1 port	IP address	192.168.3.10	192.168.3.11
	Default gateway	192.168.3.1	192.168.3.1
	Subnet mask	255.255.255.0	255.255.255.0
GE2 port	IP address	192.168.4.10	192.168.4.11
	Default gateway	192.168.4.1	192.168.4.1
	Subnet mask	255.255.255.0	255.255.255.0
GE3 port	IP address	192.168.5.10	192.168.5.11
	Default gateway	192.168.5.1	192.168.5.1
	Subnet mask	255.255.255.0	255.255.255.0
GE4 port	IP address	192.168.6.10	192.168.6.11
	Default gateway	192.168.6.1	192.168.6.1
	Subnet mask	255.255.255.0	255.255.255.0

 **NOTE**

You can change the **IP address**, **Default Gateway**, and **Subnet Mask** of a network port on the page displayed after you choose **Set > Port Settings > Ethernet**.

**Step 3** Set LAN parameters. **NOTE**

- If the SmartMGC is connected to a LAN and a proxy server has been configured, you need to cancel the proxy server configurations.
- If the SmartMGC is connected to the Internet and the PC is connected to the LAN, do not cancel the proxy server configurations.

1. Open **Control Panel** on the PC and choose **Network and Internet**.
2. Click **Internet Options** and then click the **Connections** tab.
3. Click **LAN settings**.
4. Clear **Use a proxy server for your LAN**.
5. Click **OK**.

**Step 4** Log in to the WebUI. Enter `https://XX.XX.XX.XX` (default IP address of the port connected to the network cable) in the address box of the browser to access the SmartMGC login page.

 **NOTE**

- If you are logging in to the WebUI for the first time, a security warning is displayed. Ignore the warning to continue the login.
- If the WebUI cannot be accessed and the IP address is correct, change the network port and log in again. Alternatively, log in to the app and check whether an Ethernet address conflict alarm is generated. If yes, clear the alarm according to the handling suggestions, and then log in to the WebUI.

**Step 5** Select a desired language.

**Step 6** Enter the username and password, and click **Log In**.

 **NOTE**

- For first-time access, you need to log in to the WebUI using an administrator account. The default username of the administrator account is **installer**, and there is no initial password. Set a password upon the first login.
- You will be locked out for 10 minutes after five consecutive failed password attempts in 5 minutes.
- A non-administrator user logs in to the system using the initial password provided by the administrator. After the login, the user is forced to change the password. If the password of a non-administrator account is lost, you must reset the password using an administrator account.
- If the password of the administrator account is lost, press and hold the RST button for 10s to 20s. The device parameter settings will be retained, but personal privacy and sensitive data (such as the login password and email address) will be cleared.

----End

## 6.2 WebUI Overview

---

**NOTICE**

- Only professionals are allowed to set the parameters on the WebUI. Incorrect parameter settings may affect the energy yield.
  - Historical curves of measurement points cannot be queried on the WebUI of the SmartMGC of the current version.
  - The information (such as signal names, ranges, and default values) displayed on the WebUI may vary depending on the software version or account permission.
  - If an entered signal value is not within the specified range, the signal value will be automatically changed to the minimum or maximum value in the range. (If the entered signal value is less than the minimum value, the signal value will be automatically changed to the minimum value. If the entered signal value is greater than the maximum value, the signal value will be automatically changed to the maximum value.)
-

Figure 6-1 WebUI overview

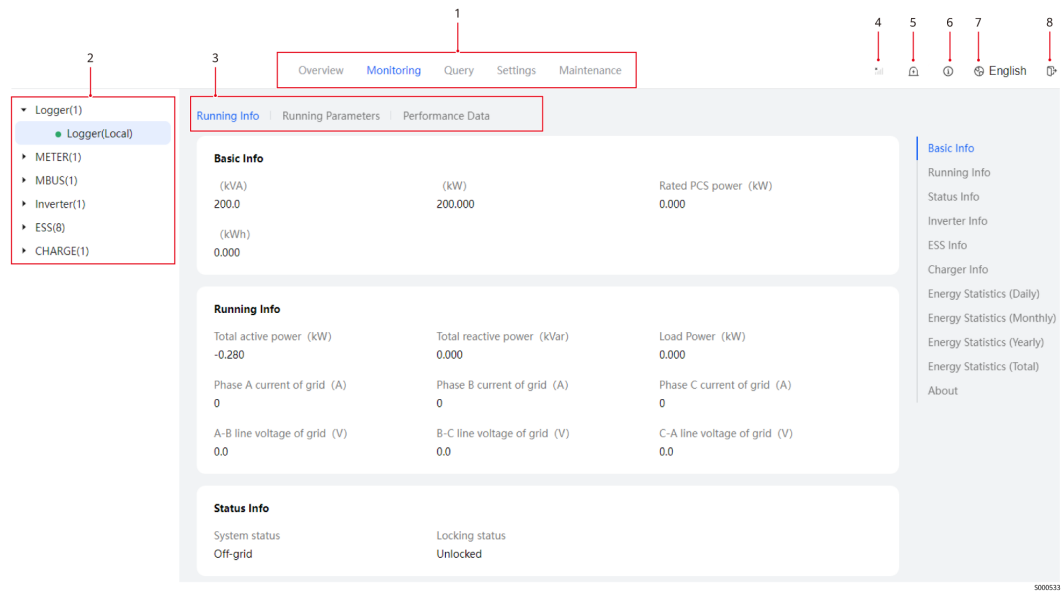

No.	Function	Description
1	First-level menu	Select a first-level menu based on actual operation requirements.
2	Second-level menu	After selecting a first-level menu, select a second-level menu based on actual operation requirements.
3	Third-level menu	After selecting a second-level menu, select a third-level menu based on actual operation requirements. (Certain pages do not have third-level menus.)
4	Signal	Displays the signal strength of the SIM card.
5	Alarm	Displays the number of active alarms.
6	About	Click to view the version information.
7	Language	Click to switch to another language.
8	Log out	Logs out of the system.

## 6.3 Overview

### NOTE

The information displayed on the UI varies depending on the devices connected to the array.

### Array Info

The **Array Info** page displays the array information, including the number, type, and status of devices.

NOTE

Path: **Overview > Array Info**

**Figure 6-2** Array info

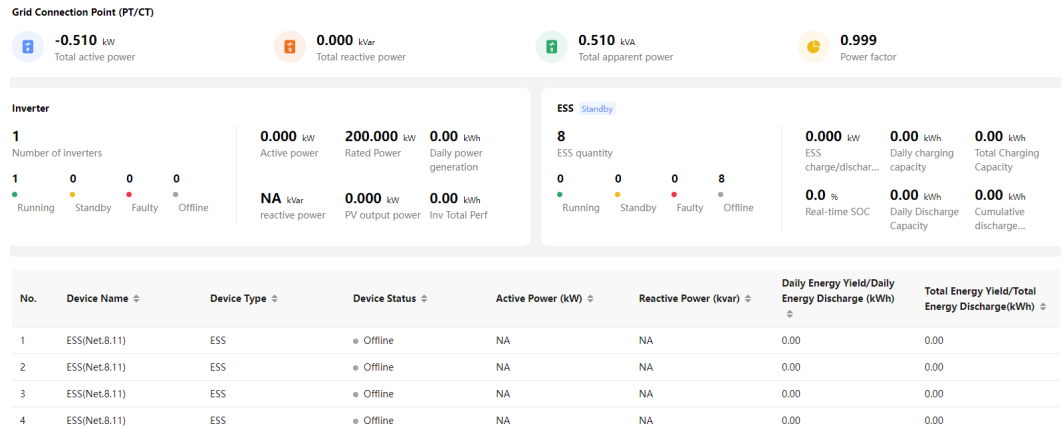

## Active Alarms

The **Active Alarms** page displays the information about active alarms. You can filter alarms by **Device** and **Severity**.

NOTE

Path: **Overview > Active Alarms**

**Figure 6-3** Active alarms

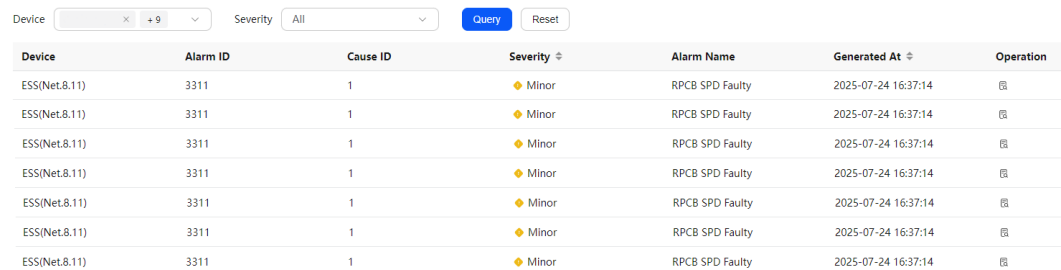

**NOTICE**

Check whether faults have been rectified based on the alarm handling suggestions. Clearing the alarm without rectifying the faults may result in device malfunction or damage.

## Mobile Network

The **Mobile Network** page displays the information about the mobile network.

NOTE

Path: **Overview > Mobile Network**

**Figure 6-4** Mobile network

No.	Signal Name	Value	Unit
1	IMEI	NA	
2	4G module version	NA	
3	4G module status	Card absent	
4	Data used this month	0.00	MB
5	Data available this month	0.00	MB
6	Average daily data usage	0.00	MB
7	Data status	Data plan not configured	

**Table 6-1** Data usage status

Status	Description
<b>Normal</b>	The data usage has not exceeded the monthly data plan, and the balance is sufficient.
<b>Warning</b>	The data usage has exceeded 90% of the monthly data plan, and the balance is insufficient.
<b>Used up</b>	The data usage has exceeded the monthly data plan. Data is used up. Top up the SIM card account immediately.
<b>Data plan not configured</b>	No data plan is configured. You can choose <b>Set &gt; Port Settings &gt; Mobile Network</b> and configure a monthly data plan.

## Sampling Info

The **Sampling Info** page displays digital and analog port information of the SmartMGC.

 **NOTE**

Path: **Overview > Sampling Info**

**Figure 6-5** Sampling info

No.	Signal Name	Value	Unit	Current Usage
1	DI1 (AI) status	Open		Idle
2	DI2 (AI) status	Open		Idle
3	DI3 (AI) status	Open		Idle
4	DI4 (AI) status	Open		Idle
5	DI1 status	Open		Optimizer rapid shutdown
6	DI2 status	Open		Idle
7	DI3 status	Open		Idle
8	DI4 status	Open		Idle
9	DO1 status	Open		Idle
10	DO2 status	Open		Idle

## Grid Connection Point Info

The **Grid Connection Point Info** page displays the information about the grid connection point.

### NOTE

- Path: **Overview > Grid Connection Point Info**
- The page is displayed only when **PT/CT sampling** is set to **Enable** on the page displayed after you choose **Set > Port Settings > PT/CT**.

**Figure 6-6** Grid connection point info

No.	Signal Name	Value	Unit
1	PT/CT wiring mode	Three-phase four-wire	
2	Microgrid Phase A voltage	0.0	V
3	Microgrid Phase B voltage	0.0	V
4	Microgrid Phase C voltage	0.0	V
5	Frequency	NA	Hz
6	Phase A voltage of grid	0.0	V
7	Phase B voltage of grid	0.0	V
8	Phase C voltage of grid	0.0	V
9	Grid frequency	NA	Hz
10	Phase A current	62	A
11	Phase B current	63	A
12	Phase C current	62	A

## Scheduling Info

The **Scheduling Info** page displays the information about remote scheduling.

### NOTE

Path: **Overview > Scheduling Info**

**Figure 6-7** Scheduling info

No.	Signal Name	Value	Unit
1	Remote scheduling-Array active power in fixed value	NA	kW
2	Remote scheduling-Array active power in percentage	NA	%
3	Remote scheduling-Array reactive power in fixed value	NA	kVar
4	Remote scheduling-Array power factor	NA	
5	Remote scheduling-Inverter active power in fixed value	NA	kW
6	Remote scheduling-Inverter active power in percentage	NA	%
7	Remote scheduling-Inverter reactive power in fixed value	NA	kVar
8	Remote scheduling-ESS active power in fixed value	NA	kW
9	Remote scheduling-ESS active power in percentage	NA	%
10	Remote scheduling-ESS reactive power in fixed value	NA	kVar

## Communication Info

The **Communication Info** page displays the information about management system interconnection.

### NOTE

Path: **Overview** > **Communication Info**

**Figure 6-8** Communication info

No.	Signal Name	Value
1	Management system IP address 1	192.168.0.11
2	Management system 1 IP address	192.168.8.11
3	GOOSE communication status	Disabled
4	AVM communication status	N/A
5	IEC104/Master-1	0.0.0.0
6	IEC104/Master-2	0.0.0.0
7	IEC104/Master-3	0.0.0.0
8	IEC104/Master-4	0.0.0.0
9	IEC104/Master-5	0.0.0.0
10	IEC104/Master-6	0.0.0.0
11	IEC104/Master-7	0.0.0.0
12	IEC104/Master-8	0.0.0.0
13	IEC104/Master-9	0.0.0.0

## 6.4 Monitoring

On the monitoring page, you can view the running information of devices and set device parameters.

### NOTE

- You can set different types of parameters separately. Select the modified parameters and click **Set** on the tab page.
- You can synchronize the same parameters for devices of the same type: Click **Batch Sync**. In the dialog box that is displayed, select the target devices and the parameters to be synchronized, and click **OK**.

### 6.4.1 Logger

#### Running Parameters

### NOTE

Path: **Monitoring** > **Logger** > **Running Parameters**

**Table 6-2 Scenario**

Parameter	Description
<b>Scenario</b>	Set this parameter to <b>On-grid</b> , <b>Off-grid</b> , or <b>On/Off-grid</b> as required.
<b>MGCC mode</b>	This parameter is displayed only when <b>Scenario</b> is set to <b>Off-grid</b> or <b>On/Off-grid</b> . <ul style="list-style-type: none"> <li>• <b>Enable</b>: Microgrid control is enabled. The microgrid control parameters are displayed.</li> <li>• <b>Disable</b>: Microgrid control is disabled.</li> </ul>

**Table 6-3 Function settings**

Parameter	Description
<b>Dispatch logging interval</b>	Specifies the interval for logging power dispatching. A shorter interval indicates a higher recording frequency.
<b>Upgrade rollback prevention</b>	Specifies whether to set <b>Upgrade rollback prevention</b> to <b>Enable</b> . If this parameter is set to <b>Enable</b> , the version cannot be rolled back during a software upgrade.
<b>Black start voltage build-up time</b>	Specifies the time for establishing array-level black start voltage. The setting is synchronized to the ESS, and the ESS must establish black start voltage within the specified time. If the ESS does not establish black start voltage within the specified time, an alarm will be generated. You are advised to set this parameter by referring to the corresponding solution manual. The default value is N/A. An incorrect setting may cause black start failure. Exercise caution when setting this parameter. If you have any question, contact technical support.

## Performance Data

On the performance data page, you can click **Export** to export device performance data.

## 6.4.2 Inverter

### Running Parameters

 **NOTE**

Path: **Monitoring > Inverter > Running Parameters**

Table 6-4 Working mode

Parameter	Description
<b>Scenario</b>	Specifies the on/off-grid scenario where the system works.
<b>Working Mode</b>	Specifies the working mode of the device based on the actual scenario.
<b>PQ mode</b>	<ul style="list-style-type: none"><li>● <b>PQ mode 1:</b> The maximum AC output power is equal to the maximum apparent power.</li><li>● <b>PQ mode 2:</b> The maximum AC output power is equal to the rated output power.</li></ul>
<b>Auto switching between working modes</b>	<ul style="list-style-type: none"><li>● <b>Disable:</b> On/Off-grid switching cannot be performed automatically.</li><li>● <b>Enable:</b> On/Off-grid switching can be performed automatically and the device does not need to be shut down before the switching.</li></ul>
<b>Working mode switching interval</b>	Specifies the time for other instructions to take effect during device working mode switching.
<b>Working mode switching delay</b>	Specifies the delay for the working mode switching to take effect.

Table 6-5 Grid parameters

Parameter	Description
<b>Grid code</b>	Set this parameter based on the grid code of the country or region where the device is located and the application scenario of the device.
<b>Voltage level</b>	Specifies the voltage level of the power grid.
<b>Frequency level</b>	Specifies the frequency level of the power grid.
<b>Isolation setting</b>	Set the working mode of the device based on the grounding status on the DC side and the connection to the power grid.
<b>Output mode</b>	Set the output mode based on the actual cable connection.
<b>Auto start upon grid recovery</b>	<ul style="list-style-type: none"><li>● <b>Enable:</b> The inverter automatically starts when the power grid recovers from a fault or outage.</li><li>● <b>Disable:</b> The inverter does not automatically start when the power grid recovers from a fault or outage. The inverter starts only after a startup command is delivered</li></ul>

Parameter	Description
<b>Grid connection delay after grid recovery</b>	Specifies the delay period before device restart following grid recovery.
<b>Short-term power grid interruption and quick start</b>	<ul style="list-style-type: none"><li>• <b>Disable:</b> After the power grid recovers from a short-time disconnection, the system connects to the power grid by following the normal startup process.</li><li>• <b>Enable:</b> After the power grid recovers from a short-time disconnection, certain detection items are skipped to achieve quick connection to the power grid.</li></ul>
<b>Time for determining short-time power grid interruption</b>	This parameter is displayed when <b>Short-term power grid interruption and quick start</b> is set to <b>Enable</b> . The parameter specifies the duration for determining whether the grid is disconnected for a short time. A short-time grid disconnection is determined by checking whether the power grid can recover within the period specified by <b>Time for determining short-time power grid interruption</b> .
<b>Power-on soft start time due to power grid faults</b>	Specifies the time for the power to gradually increase when the device restarts after the power grid recovers.
<b>Restart mode after grid failure</b>	Specifies the restart mode after a power grid failure.
<b>Maximum grid voltage for grid reconnection</b>	After the device is shut down due to a fault, it cannot reconnect to the power grid if the grid voltage is higher than the value of this parameter.
<b>Minimum grid voltage for grid reconnection</b>	After the device is shut down due to a fault, it cannot reconnect to the power grid if the grid voltage is lower than the value of this parameter.
<b>Maximum grid frequency for grid reconnection</b>	After the device is shut down due to a fault, it cannot reconnect to the power grid if the grid frequency is higher than the value of this parameter.
<b>Minimum grid frequency for grid reconnection</b>	After the device is shut down due to a fault, it cannot reconnect to the power grid if the grid frequency is lower than the value of this parameter.
<b>Maximum grid voltage for grid connection</b>	When the device is started for the first time for grid connection, it cannot connect to the power grid if the grid voltage is higher than the value of this parameter.
<b>Minimum grid voltage for grid connection</b>	When the device is started for the first time for grid connection, it cannot connect to the power grid if the grid voltage is lower than the value of this parameter.

Parameter	Description
<b>Maximum grid frequency for grid connection</b>	When the device is started for the first time for grid connection, it cannot connect to the power grid if the grid frequency is higher than the value of this parameter.
<b>Minimum grid frequency for grid connection</b>	When the device is started for the first time for grid connection, it cannot connect to the power grid if the grid frequency is lower than the value of this parameter.
<b>Power grid automatic reconnection time</b>	Specifies the delay period before device restart following grid recovery.

**Table 6-6** Parameter setting

Parameter	Description
<b>Altitude</b>	Set this parameter as required.
<b>shutdown gradient</b>	Specifies the power change rate until the device shuts down.
<b>PV module type</b>	<p>Specifies the type of PV modules supported by the inverter. This parameter is used to set the shutdown time for concentrating PV (CPV) modules, but not for crystalline silicon or thin-film PV modules. If the CPV modules are shaded, the power drops drastically to 0 and the inverter shuts down. The energy yield would be affected since it takes too long for the power to resume and the inverter to restart.</p> <ul style="list-style-type: none"> <li>● <b>Crystalline silicon</b> or <b>Thin film</b>: When PV modules are shaded, the inverter automatically detects the module power. If the power is insufficient, the inverter automatically shuts down.</li> <li>● When CPV modules are used: <ul style="list-style-type: none"> <li>– <b>CPV 1</b>: When the input power from PV modules drops sharply due to shading, the inverter can quickly restart within 60 minutes.</li> <li>– <b>CPV 2</b>: When the input power from PV modules drops sharply due to shading, the inverter can quickly restart within 10 minutes.</li> </ul> </li> </ul>
<b>String connection mode</b>	<ul style="list-style-type: none"> <li>● When each PV string is separately connected to an inverter (all separated), you do not need to set this parameter. The inverter can automatically detect and identify the PV string connection mode.</li> <li>● When the inverter is connected to all parallel PV strings (all connected in parallel), set this parameter to <b>All connected in parallel</b>.</li> </ul>

Parameter	Description
Soft start time	Specifies the duration for the power to gradually increase until the device starts.
RS485-2 communication	Specifies whether to set <b>RS485-2 communication</b> to <b>Enable</b> .
RS485-1 port mode	Specifies the mode of the RS485-1 port.
RS485-2 port mode	Specifies the mode of the RS485-2 port.

Table 6-7 Function configuration

Parameter	Description
V-phase grounded	Specifies whether to set <b>V-phase grounded</b> to <b>Enable</b> . The default value is <b>Disable</b> . Set this parameter to <b>Enable</b> when the phase wire from the transformer to the inverter is grounded.
Hibernate at night	Specifies whether to set <b>Hibernate at night</b> to <b>Enable</b> . The device can keep monitoring at night. If this parameter is set to <b>Enable</b> , the device hibernates at night to reduce energy consumption.
Anti-freezing at night	Specifies whether to set <b>Anti-freezing at night</b> to <b>Enable</b> .
I-V curve scanning	Specifies whether to start I-V curve scanning.
Microgrid compatibility	<ul style="list-style-type: none"><li>• <b>Disable</b>: Set this parameter to <b>Disable</b> when <b>Working Mode</b> is set to <b>VSG</b> or <b>Scenario</b> is set to <b>On-grid</b>.</li><li>• <b>Enable</b>: If <b>Working Mode</b> is set to <b>PQ</b> for the device and the device works in a microgrid that uses a diesel generator or other voltage sources, set this parameter to <b>Enable</b>. If this parameter is set to <b>Enable</b>, the device adaptively changes the output power based on the original grid code and the grid voltage and frequency to support a higher ratio of current sources to voltage sources (that is, PV-to-ESS ratio).</li></ul>
PID protection at night	Specifies whether to set <b>PID protection at night</b> to <b>Enable</b> . When the inverter outputs reactive power at night and this parameter is set to <b>Enable</b> , the inverter will shut down automatically if it detects abnormal status of the PID voltage compensation.
Grounding exception detection	Specifies whether to set <b>Grounding exception detection</b> to <b>Enable</b> .

Parameter	Description
<b>Shutdown on abnormal grounding</b>	Specifies whether to set <b>Shutdown on abnormal grounding</b> to <b>Enable</b> .
<b>Harmonic optimization type</b>	Specifies the object of power quality optimization. You can set this parameter to <b>Harmonic voltage</b> or <b>Harmonic current</b> .
<b>Physical location</b>	Specifies the physical location.
<b>Shutdown at 0% power limit</b>	Specifies whether to set <b>Shutdown at 0% power limit</b> to <b>Enable</b> . If this parameter is set to <b>Enable</b> , the device shuts down when it receives a command for limiting power to 0%.
<b>OVGR linked shutdown</b>	Specifies whether to set <b>OVGR linked shutdown</b> to <b>Enable</b> . If this parameter is set to <b>Enable</b> , the device shuts down when receiving an OVGR signal.
<b>Nighttime off-grid recovery</b>	Specifies whether to set <b>Nighttime off-grid recovery</b> to <b>Enable</b> . This parameter is displayed when <b>Built-in PID running mode</b> is set to <b>Recovery</b> or <b>Suppression +Recovery</b> .
<b>Daytime off-grid recovery</b>	Specifies whether to set <b>Daytime off-grid recovery</b> to <b>Enable</b> . This parameter is displayed when <b>Built-in PID running mode</b> is set to <b>Recovery</b> or <b>Suppression +Recovery</b> .
<b>Built-in PID running mode</b>	Specifies the built-in PID running mode.
<b>Power quality optimization mode</b>	Specifies whether to set <b>Power quality optimization mode</b> to <b>Enable</b> . If this parameter is set to <b>Enable</b> , the output current harmonics of the device are optimized.
<b>Auto recovery from string-to-ground short-circuit protection</b>	Specifies whether to set <b>Auto recovery from string-to-ground short-circuit protection</b> to <b>Enable</b> .

Table 6-8 Protection configuration

Parameter	Description
<b>Phase protection threshold</b>	The Japanese standard requires that during passive islanding, protection be triggered if an abrupt voltage phase change is detected.

Parameter	Description
<b>Phase angle offset protection</b>	Specifies whether to set <b>Auto recovery from string-to-ground short-circuit protection</b> to <b>Enable</b> . Protection is triggered if the phase angle offset of the three phases of the power grid exceeds a certain value.
<b>Active Islanding Protection</b>	Specifies whether to set <b>Active Islanding Protection</b> to <b>Enable</b> .
<b>Passive island protection</b>	Specifies whether to set <b>Enable</b> to <b>Enable</b> .
<b>Insulation resistance protection threshold</b>	To ensure device safety, the device detects the insulation resistance of the DC side to the ground when it starts a self-check. If the detected value is less than the preset value, the device does not start.
<b>Voltage imbalance protection threshold</b>	Specifies the threshold for device protection when the power grid voltage is unbalanced.
<b>Frequency Rate Change Protection</b>	Specifies whether to set <b>Frequency Rate Change Protection</b> to <b>Enable</b> . If the function is enabled, the device triggers protection when the power grid frequency changes too fast.
<b>Frequency change rate protection threshold</b>	This parameter is displayed when <b>Frequency Rate Change Protection</b> is set to <b>Enable</b> . It specifies the frequency change rate protection threshold.
<b>Duration threshold for frequency change rate protection</b>	This parameter is displayed when <b>Frequency Rate Change Protection</b> is set to <b>Enable</b> . It specifies the frequency change rate protection duration.

**Table 6-9** Overvoltage protection

Parameter	Description
<b>10-minute overvoltage protection threshold</b>	Specifies the 10-minute overvoltage protection threshold.
<b>Duration threshold for 10-minute overvoltage protection</b>	Specifies the duration threshold for 10-minute overvoltage protection.

Parameter	Description
<b>Level <math>\alpha</math> overvoltage protection threshold<sup>[1]</sup></b>	Level $\alpha$ overvoltage protection threshold $\leq$ Level $\alpha+1$ overvoltage protection threshold
<b>Duration threshold for level <math>\alpha</math> overvoltage protection<sup>[1]</sup></b>	Duration threshold for level $\alpha$ overvoltage protection $\geq$ Duration threshold for level $\alpha+1$ overvoltage protection
[1]: $\alpha = 1-6$	

**Table 6-10** Undervoltage protection

Parameter	Description
<b>Ten-minute undervoltage protection threshold</b>	Specifies the 10-minute undervoltage protection threshold.
<b>10 minutes undervoltage protection time</b>	Specifies the duration threshold for 10-minute undervoltage protection.
<b>Level <math>\alpha</math> undervoltage protection threshold<sup>[1]</sup></b>	Level $\alpha$ undervoltage protection threshold $\geq$ Level $\alpha+1$ undervoltage protection threshold
<b>Duration threshold for level <math>\alpha</math> undervoltage protection<sup>[1]</sup></b>	Duration threshold for level $\alpha$ undervoltage protection $\geq$ Duration threshold for level $\alpha+1$ undervoltage protection
[1]: $\alpha = 1-6$	

**Table 6-11** Overfrequency protection

Parameter	Description
<b>Level <math>\alpha</math> overfrequency protection threshold<sup>[1]</sup></b>	Level $\alpha$ overfrequency protection threshold $\leq$ Level $\alpha+1$ overfrequency protection threshold

Parameter	Description
<b>Duration threshold for level <math>\alpha</math> overfrequency protection<sup>[1]</sup></b>	Duration threshold for level $\alpha$ overfrequency protection $\geq$ Duration threshold for level $\alpha+1$ overfrequency protection
[1]: $\alpha = 1-6$	

**Table 6-12** Underfrequency protection

Parameter	Description
<b>Level <math>\alpha</math> underfrequency protection threshold<sup>[1]</sup></b>	Level $\alpha$ underfrequency protection threshold $\geq$ Level $\alpha+1$ underfrequency protection threshold
<b>Duration threshold for level <math>\alpha</math> underfrequency protection<sup>[1]</sup></b>	Duration threshold for level $\alpha$ underfrequency protection $\geq$ Duration threshold for level $\alpha+1$ underfrequency protection
[1]: $\alpha = 1-6$	

**Table 6-13** Grid forming control

Parameter	Description
<b>On-grid VSG inertia time constant</b>	Specifies the time required for the virtual rotor of the GFM-related virtual synchronous generator to reach the rated speed from the static state under the rated torque.
<b>Active power frequency regulation coefficient in grid forming mode</b>	This parameter is displayed when <b>Working Mode</b> is set to <b>VSG</b> . It specifies the ratio of the per unit value of the active power variation to the per unit value of the frequency variation for the frequency regulation.
<b>Reactive power voltage regulation coefficient in grid forming mode</b>	This parameter is displayed when <b>Working Mode</b> is set to <b>VSG</b> . It specifies the ratio of the per unit value of the reactive power variation to the per unit value of the root mean square voltage variation for the voltage regulation.
<b>Active power frequency regulation deadband in grid forming mode</b>	This parameter is displayed when <b>Working Mode</b> is set to <b>VSG</b> . It specifies the active power frequency regulation deadband in grid forming mode.

Parameter	Description
<b>Reactive power voltage regulation deadband in grid forming mode</b>	This parameter is displayed when <b>Working Mode</b> is set to <b>VSG</b> . It specifies the reactive power voltage regulation deadband in grid forming mode.
<b>Upper limit of active power variation for frequency regulation in grid forming mode</b>	This parameter is displayed when <b>Working Mode</b> is set to <b>VSG</b> . It specifies the maximum percentage of the active power variation for the frequency regulation. The upper limit can be set to the per unit value of <b>Active power reference</b> .
<b>Lower limit of active power variation for frequency regulation in grid forming mode</b>	This parameter is displayed when <b>Working Mode</b> is set to <b>VSG</b> . It specifies the minimum percentage of the active power variation for the frequency regulation. The lower limit can be set to the per unit value of <b>Active power reference</b> .
<b>Upper limit of reactive power variation for voltage regulation in grid forming mode</b>	This parameter is displayed when <b>Working Mode</b> is set to <b>VSG</b> . It specifies maximum percentage of the reactive power variation for the voltage regulation. The upper limit can be set to three times the per unit value of <b>apparent power reference</b> .
<b>Lower limit of reactive power variation for voltage regulation in grid forming mode</b>	This parameter is displayed when <b>Working Mode</b> is set to <b>VSG</b> . It specifies the minimum percentage of the reactive power variation for the frequency regulation. The lower limit can be set to three times the per unit value of <b>apparent power reference</b> .
<b>Grid forming mode certificate</b>	Specifies whether to enable the certificate for grid forming mode.
<b>Grid-Forming Control Frequency Damping Dead Band</b>	This parameter is displayed when <b>Grid forming mode certificate</b> is set to <b>Started</b> . It specifies the frequency damping deadband.
<b>Grid-Forming Control Frequency Damping Coefficient</b>	This parameter is displayed when <b>Grid forming mode certificate</b> is set to <b>Started</b> . It specifies the frequency damping coefficient.
<b>Grid-Forming Control Power Damping Coefficient</b>	This parameter is displayed when <b>Grid forming mode certificate</b> is set to <b>Started</b> . It specifies the power damping coefficient.

Parameter	Description
<b>Reactive power voltage regulation baseline in grid forming mode</b>	This parameter is displayed when <b>Grid forming mode certificate</b> is set to <b>Started</b> . It specifies the reactive power voltage regulation baseline in grid forming mode.
<b>Active power frequency regulation baseline in grid forming mode</b>	This parameter is displayed when <b>Grid forming mode certificate</b> is set to <b>Started</b> . It specifies the active power voltage regulation baseline in grid forming mode.
<b>Virtual impedance excitation control in grid forming mode</b>	This parameter is displayed when <b>Grid forming mode certificate</b> is set to <b>Started</b> . It specifies whether to set <b>Virtual impedance excitation control in grid forming mode</b> to <b>Enable</b> .
<b>Excitation virtual impedance in grid forming mode</b>	This parameter is displayed when <b>Virtual impedance excitation control in grid forming mode</b> is set to <b>Enable</b> . It specifies the excitation virtual impedance in grid forming mode.
<b>Automatic voltage control for extremely weak grid</b>	Specifies whether to set <b>Automatic voltage control for extremely weak grid</b> to <b>Enable</b> .
<b>Excitation compensation impedance in extremely weak grid</b>	This parameter is displayed when <b>Automatic voltage control for extremely weak grid</b> is set to <b>Enable</b> . It specifies the excitation compensation impedance in an extremely weak grid.
<b>Reserve power for grid forming control</b>	Specifies whether to set <b>Reserve power for grid forming control</b> to <b>Enable</b> .
<b>Power reserved for grid forming control</b>	This parameter is displayed when <b>Reserve power for grid forming control</b> is set to <b>Enable</b> . It specifies the power reserved for grid forming control.
<b>Component exception detection and protection</b>	Specifies whether to enable component exception detection and protection.

Table 6-14 Off-grid control

Parameter	Description
<b>P-F adjustment coefficient</b>	This parameter is displayed when <b>Working Mode</b> is set to <b>VSG</b> . It specifies the frequency deviation corresponding to the rated active power of the virtual synchronous generator.
<b>Q-F adjustment coefficient</b>	This parameter is displayed when <b>Working Mode</b> is set to <b>VSG</b> . It specifies the frequency deviation corresponding to the rated reactive power of the virtual synchronous generator.
<b>P-V adjustment coefficient</b>	This parameter is displayed when <b>Working Mode</b> is set to <b>VSG</b> . It specifies the voltage deviation corresponding to the rated active power of the virtual synchronous generator.
<b>Q-V adjustment coefficient</b>	This parameter is displayed when <b>Working Mode</b> is set to <b>VSG</b> . It specifies the voltage deviation corresponding to the rated reactive power of the virtual synchronous generator.
<b>VSG frequency damping coefficient</b>	This parameter is displayed when <b>Working Mode</b> is set to <b>VSG</b> . It specifies the power factor that prevents the frequency change of the virtual synchronous generator.
<b>VSG excitation time constant</b>	This parameter is displayed when <b>Working Mode</b> is set to <b>VSG</b> . It specifies the time required for the excitation of the virtual synchronous generator to reach the rated voltage.
<b>VSG excitation damping coefficient</b>	This parameter is displayed when <b>Working Mode</b> is set to <b>VSG</b> . It specifies the power factor that prevents the voltage change of the virtual synchronous generator.
<b>VSG output voltage correction coefficient</b>	This parameter is displayed when <b>Working Mode</b> is set to <b>VSG</b> . It corrects the deviation caused by the transformer ratio error.
<b>VSG output frequency correction coefficient</b>	This parameter is displayed when <b>Working Mode</b> is set to <b>VSG</b> . It corrects the inverter output frequency deviation.
<b>Per unit armature resistance</b>	This parameter is displayed when <b>Working Mode</b> is set to <b>VSG</b> . It specifies the resistance per unit value for armature windings of the virtual synchronous generator.
<b>Per unit armature inductive reactance</b>	This parameter is displayed when <b>Working Mode</b> is set to <b>VSG</b> . It specifies the inductive reactance per unit value for armature windings of the virtual synchronous generator.
<b>Wired carrier synchronization</b>	This parameter is displayed when <b>Working Mode</b> is set to <b>VSG</b> . Specifies whether to set <b>Wired carrier synchronization</b> to <b>Enable</b> .

Parameter	Description
<b>Delay compensation for wired carrier synchronization</b>	This parameter is displayed when <b>Wired carrier synchronization</b> is set to <b>Enable</b> . It specifies the value of delay compensation for wired carrier synchronization.
<b>Wired power frequency synchronization</b>	This parameter is displayed when <b>Working Mode</b> is set to <b>VSG</b> . It specifies whether to set <b>Wired power frequency synchronization</b> to <b>Enable</b> .
<b>Delay compensation for wired power frequency synchronization</b>	This parameter is displayed when <b>Wired power frequency synchronization</b> is set to <b>Enable</b> . It specifies the value of delayed compensation for wired power frequency synchronization.
<b>Off-grid VSG inertia time constant</b>	This parameter is displayed when <b>Working Mode</b> is set to <b>VSG</b> . It specifies the time required for the virtual rotor of the virtual synchronous generator to reach the rated speed from the static state under the rated torque.

Table 6-15 VRT configuration

Parameter	Description
<b>Zero-current mode on power grid fault</b>	Specifies whether to set <b>Zero-current mode on power grid fault</b> to <b>Enable</b> .
<b>Grid voltage trip triggering threshold</b>	This parameter is displayed when <b>LVRT</b> or <b>HVRT</b> is set to <b>Enable</b> . If the grid voltage exceeds the value of this parameter, <b>LVRT</b> or <b>HVRT</b> will be triggered.
<b>VRT exit hysteresis threshold</b>	This parameter is displayed when <b>LVRT</b> or <b>HVRT</b> is set to <b>Enable</b> . It specifies the LVRT/HVRT recovery threshold. <ul style="list-style-type: none"> <li>• LVRT recovery threshold = LVRT triggering threshold + VRT exit hysteresis threshold</li> <li>• HVRT recovery threshold = HVRT triggering threshold - VRT exit hysteresis threshold</li> </ul>
<b>VRT active power recovery gradient</b>	This parameter is displayed when <b>LVRT</b> or <b>HVRT</b> is set to <b>Enable</b> . It specifies the gradient for the active current to restore to the value at the moment before fault ride-through.
<b>Deactivate grid voltage protection during VRT</b>	This parameter is displayed when <b>LVRT</b> or <b>HVRT</b> is set to <b>Enable</b> . It specifies whether to set <b>Deactivate grid voltage protection during VRT</b> to <b>Enable</b> .
<b>VRT active current limiting (%)</b>	This parameter is displayed when <b>LVRT</b> or <b>HVRT</b> is set to <b>Enable</b> . It specifies the percentage of the maximum active current to the rated current during fault ride-through.

**Table 6-16 HVRT**

<b>Parameter</b>	<b>Description</b>
<b>HVRT</b>	HVRT is short for high voltage ride-through. When the grid voltage is abnormally high for a short time, the device shall not disconnect from the power grid immediately and has to work for some time.
<b>HVRT triggering threshold</b>	This parameter is displayed when <b>HVRT</b> is set to <b>Enable</b> . It specifies the threshold for triggering HVRT. The value must comply with the local power grid standard.
<b>HVRT zero current trigger voltage</b>	Specifies the HVRT zero current trigger voltage.
<b>Positive-sequence reactive power compensation factor in HVRT</b>	This parameter is displayed when <b>HVRT</b> is set to <b>Enable</b> . During HVRT, the inverter needs to generate positive-sequence reactive power to support the power grid. This parameter is used to set the positive-sequence reactive power generated by the inverter.  For example, if you set this parameter to <b>2</b> , the increment of positive-sequence reactive current generated by the inverter is 20% of the rated current when the AC voltage increases by 10% during HVRT.
<b>Negative-sequence reactive power compensation factor in HVRT</b>	This parameter is displayed when <b>HVRT</b> is set to <b>Enable</b> . During HVRT, the inverter needs to generate negative-sequence reactive power to support the power grid. This parameter is used to set the negative-sequence reactive power generated by the inverter.  For example, if you set this parameter to <b>2</b> , the increment of negative-sequence reactive current generated by the inverter is 20% of the rated current when the AC voltage increases by 10% during HVRT.
<b>Power dispatching hold time after HVRT</b>	This parameter is displayed when <b>HVRT</b> is set to <b>Enable</b> . It specifies the delay for the device to stop the power dispatching response after HVRT. After the stopping state ends, the device starts to respond to the dispatching command.
<b>Reactive current compensation bias during HVRT</b>	This parameter is displayed when <b>HVRT</b> is set to <b>Enable</b> . Specifies the percentage of the reactive compensation current in the rated current during HVRT.
<b>Reactive current limit during HVRT (%)</b>	This parameter is displayed when <b>HVRT</b> is set to <b>Enable</b> . During HVRT, the device needs to limit the reactive current.

Parameter	Description
<b>HVRT in grid forming mode</b>	This parameter is displayed when <b>HVRT</b> is set to <b>Enable</b> , <b>Working Mode</b> is set to <b>VSG</b> , and <b>Scenario</b> is set to <b>On-grid</b> . It specifies whether to set <b>HVRT in grid forming mode</b> to <b>Enable</b> .
<b>HVRT priority in grid forming mode</b>	This parameter is displayed when <b>HVRT in grid forming mode</b> is set to <b>Enable</b> . It specifies the HVRT priority in grid forming mode.
<b>Voltage regulation type of HVRT in grid forming mode</b>	This parameter is displayed when <b>HVRT in grid forming mode</b> is set to <b>Enable</b> . It specifies the voltage regulation type of HVRT in grid forming mode.
<b>Voltage regulation coefficient of HVRT in grid forming mode</b>	This parameter is displayed when <b>HVRT in grid forming mode</b> is set to <b>Enable</b> . It specifies the voltage regulation coefficient of HVRT in grid forming mode.
<b>Minimum HVRT duration in grid forming mode</b>	This parameter is displayed when <b>HVRT in grid forming mode</b> is set to <b>Enable</b> . It specifies the minimum duration of HVRT.

Table 6-17 LVRT

Parameter	Description
<b>LVRT</b>	LVRT is short for low voltage ride-through. When the grid voltage is abnormally low for a short time, the device shall not disconnect from the power grid immediately and has to work for some time.
<b>LVRT mode</b>	This parameter is displayed when <b>LVRT</b> is set to <b>Enable</b> . It specifies the LVRT mode.
<b>LVRT triggering threshold</b>	This parameter is displayed when <b>LVRT</b> is set to <b>Enable</b> . It specifies the threshold for triggering LVRT. The value must meet the requirements of the local power grid standard.
<b>Threshold of LVRT zero-current mode</b>	This parameter is displayed when <b>LVRT</b> is set to <b>Enable</b> . If <b>Zero-current mode on power grid fault</b> is set to <b>Enable</b> and the grid voltage is lower than the value of this parameter during LVRT, the zero current mode is used. Otherwise, the mode specified by <b>LVRT mode</b> is used.

Parameter	Description
<b>Positive-sequence reactive power compensation factor in LVRT</b>	<p>This parameter is displayed when <b>LVRT</b> is set to <b>Enable</b>. During LVRT, the inverter needs to generate positive-sequence reactive power to support the power grid. This parameter is used to set the positive-sequence reactive power generated by the inverter.</p> <p>For example, if you set this parameter to <b>2</b>, the increment of positive-sequence reactive current generated by the inverter is 20% of the rated current when the AC voltage decreases by 10% during LVRT.</p>
<b>Negative-sequence reactive power compensation factor in LVRT</b>	<p>This parameter is displayed when <b>LVRT</b> is set to <b>Enable</b>. During LVRT, the inverter needs to generate negative-sequence reactive power to support the power grid. This parameter is used to set the negative-sequence reactive power generated by the inverter.</p> <p>For example, if you set this parameter to <b>2</b>, the increment of negative-sequence reactive current generated by the inverter is 20% of the rated current when the AC voltage decreases by 10% during LVRT.</p>
<b>LVRT active current maintenance coefficient</b>	<p>This parameter is displayed when <b>LVRT</b> is set to <b>Enable</b>. It specifies the proportional coefficient of the active current during LVRT to the active current before LVRT.</p>
<b>Power dispatching hold time after LVRT</b>	<p>This parameter is displayed when <b>LVRT</b> is set to <b>Enable</b>. It specifies the delay for the device to stop the power dispatching response after LVRT. After the stopping state ends, the device starts to respond to the dispatching command.</p>
<b>Reactive current compensation bias during LVRT</b>	<p>This parameter is displayed when <b>LVRT</b> is set to <b>Enable</b>. Specifies the percentage of the reactive compensation current in the rated current during LVRT.</p>
<b>Compensation angle during ZVRT</b>	<p>This parameter is displayed when <b>LVRT</b> is set to <b>Enable</b>. It specifies the compensation angle during ZVRT.</p>
<b>LVRT reactive current limiting (%)</b>	<p>This parameter is displayed when <b>LVRT</b> is set to <b>Enable</b>. During LVRT, the inverter needs to limit the reactive current.</p> <p>For example, if this parameter is set to <b>50</b>, the upper limit of the reactive current of the inverter is 50% of the rated current during LVRT.</p>
<b>Positive-sequence reactive current limit during asymmetric LVRT (%)</b>	<p>This parameter is displayed when <b>LVRT</b> is set to <b>Enable</b>. During asymmetric LVRT, the device needs to limit the positive-sequence reactive current.</p>

Parameter	Description
<b>LVRT in grid forming mode</b>	This parameter is displayed when <b>LVRT</b> is set to <b>Enable</b> , <b>Working Mode</b> is set to <b>VSG</b> , and <b>Scenario</b> is set to <b>On-grid</b> . It specifies whether to set <b>LVRT in grid forming mode</b> to <b>Enable</b> .
<b>LVRT priority in grid forming mode</b>	This parameter is displayed when <b>LVRT in grid forming mode</b> is set to <b>Enable</b> . It specifies the LVRT priority in grid forming mode.
<b>Voltage regulation type of LVRT in grid forming mode</b>	This parameter is displayed when <b>LVRT in grid forming mode</b> is set to <b>Enable</b> . It specifies the voltage regulation type of LVRT in grid forming mode.
<b>Voltage regulation coefficient of LVRT in grid forming mode</b>	This parameter is displayed when <b>LVRT in grid forming mode</b> is set to <b>Enable</b> . It specifies the voltage regulation coefficient of LVRT in grid forming mode.
<b>Minimum LVRT duration in grid forming mode</b>	This parameter is displayed when <b>LVRT in grid forming mode</b> is set to <b>Enable</b> . It specifies the minimum duration of LVRT.

Table 6-18 Frequency regulation control

Parameter	Description
<b>Frequency regulation control</b>	Specifies whether to set <b>Frequency regulation control</b> to <b>Enable</b> .
<b>Adjustment ratio for frequency regulation control</b>	This parameter is displayed when <b>Frequency regulation control</b> is set to <b>Enable</b> . According to the standards of certain countries or regions, if the power grid frequency fluctuates around the rated value, the device needs to fine-tune the active power output based on <b>Adjustment ratio for frequency regulation control</b> to help stabilize the grid frequency.
<b>Response deadband for frequency regulation control</b>	This parameter is displayed when <b>Frequency regulation control</b> is set to <b>Enable</b> . It specifies the threshold for triggering frequency regulation. For example, if this parameter is set to 0.1 Hz, frequency regulation is not triggered when the frequency is within reference frequency $\pm$ 0.1 Hz.
<b>Power change gradient for frequency regulation control</b>	This parameter is displayed when <b>Frequency regulation control</b> is set to <b>Enable</b> . It specifies the power change gradient for frequency regulation control.

Parameter	Description
<b>Power change limit for frequency regulation control</b>	This parameter is displayed when <b>Frequency regulation control</b> is set to <b>Enable</b> . It specifies the power change limit for frequency regulation control.
<b>Delay of frequency regulation control</b>	This parameter is displayed when <b>Frequency regulation control</b> is set to <b>Enable</b> . It specifies the delay of frequency regulation control.
<b>Upper power change limit of frequency-based control</b>	This parameter is displayed when <b>Frequency regulation control</b> is set to <b>Enable</b> . It specifies the upper power change limit for frequency regulation control.
<b>Lower power change limit of frequency-based control</b>	This parameter is displayed when <b>Frequency regulation control</b> is set to <b>Enable</b> . It specifies the lower power change limit for frequency regulation control.
<b>Frequency detection filter time</b>	This parameter is displayed when <b>Frequency regulation control</b> , <b>Underfrequency-caused power raising</b> , or <b>Overfrequency-caused power derating</b> is set to <b>Enable</b> . It specifies the frequency detection filter time.
<b>Hysteresis of frequency-based active power derating</b>	This parameter is displayed when <b>Frequency regulation control</b> , <b>Underfrequency-caused power raising</b> , or <b>Overfrequency-caused power derating</b> is set to <b>Enable</b> . It specifies whether to set <b>Hysteresis of frequency-based active power derating</b> to <b>Enable</b> .
<b>Transition frequency in overfrequency-caused power derating</b>	This parameter is displayed when <b>Overfrequency-caused power derating</b> is set to <b>Enable</b> . It specifies the transition frequency in overfrequency-caused power derating.
<b>Recovery delay of frequency-based active power derating</b>	This parameter is displayed when <b>Frequency regulation control</b> , <b>Underfrequency-caused power raising</b> , or <b>Overfrequency-caused power derating</b> is set to <b>Enable</b> . It specifies the delay time for exiting overfrequency-caused power derating after the frequency reaches the specified threshold. It specifies the recovery delay of frequency-based active power derating.
<b>Execution delay of frequency-based active power derating</b>	This parameter is displayed when <b>Frequency regulation control</b> , <b>Underfrequency-caused power raising</b> , or <b>Overfrequency-caused power derating</b> is set to <b>Enable</b> . It specifies the execution delay of frequency-based active power derating.

**Table 6-19** Overfrequency-caused power derating

Parameter	Description
<b>Overfrequency-caused power derating</b>	Specifies whether to set <b>Overfrequency-caused power derating</b> to <b>Enable</b> .
<b>Frequency threshold for triggering overfrequency-caused power derating</b>	This parameter is displayed when <b>Overfrequency-caused power derating</b> is set to <b>Enable</b> . When the power grid frequency exceeds the <b>Frequency threshold for triggering overfrequency-caused power derating</b> , the active power of the device is derated based on a certain gradient. When setting this parameter, ensure that the following condition is met: <b>Frequency threshold for exiting overfrequency-caused power derating</b> $\leq$ <b>Frequency threshold for triggering overfrequency-caused power derating</b> $<$ <b>Frequency threshold for stopping overfrequency-caused power derating</b> .
<b>Frequency threshold for exiting overfrequency-caused power derating</b>	This parameter is displayed when <b>Overfrequency-caused power derating</b> is set to <b>Enable</b> . When setting this parameter, ensure that the following condition is met: <b>Frequency threshold for exiting overfrequency-caused power derating</b> $\leq$ <b>Frequency threshold for triggering overfrequency-caused power derating</b> $<$ <b>Frequency threshold for stopping overfrequency-caused power derating</b> .
<b>Frequency threshold for stopping overfrequency-caused power derating</b>	This parameter is displayed when <b>Overfrequency-caused power derating</b> is set to <b>Enable</b> . When setting this parameter, ensure that the following condition is met: <b>Frequency threshold for exiting overfrequency-caused power derating</b> $\leq$ <b>Frequency threshold for triggering overfrequency-caused power derating</b> $<$ <b>Frequency threshold for stopping overfrequency-caused power derating</b> .
<b>Power threshold for stopping overfrequency-caused power derating</b>	This parameter is displayed when <b>Overfrequency-caused power derating</b> is set to <b>Enable</b> . It specifies the power threshold for stopping overfrequency-caused power derating.
<b>Response time of overfrequency-caused power derating</b>	This parameter is displayed when <b>Overfrequency-caused power derating</b> is set to <b>Enable</b> . Specifies the response time of overfrequency-caused power derating.
<b>Gradient of power recovery from overfrequency-caused derating</b>	This parameter is displayed when <b>Overfrequency-caused power derating</b> is set to <b>Enable</b> . It specifies the gradient of power recovery from overfrequency-caused derating.

Parameter	Description
<b>Gradient of overfrequency-caused power derating</b>	This parameter is displayed when <b>Overfrequency-caused power derating</b> is set to <b>Enable</b> . It specifies the gradient of overfrequency-caused power derating.

**Table 6-20** Underfrequency-caused power raising

Parameter	Description
<b>Underfrequency-caused power raising</b>	Specifies whether to set <b>Underfrequency-caused power raising</b> to <b>Enable</b> .
<b>Frequency threshold for triggering underfrequency-caused power raising</b>	This parameter is displayed when <b>Underfrequency-caused power raising</b> is set to <b>Enable</b> . The standards of certain countries and regions require that if the power grid frequency is lower than <b>Frequency threshold for triggering underfrequency-caused power raising</b> , the device needs to increase the active power output to raise the power grid frequency.
<b>Transition frequency in underfrequency-caused power raising</b>	This parameter is displayed when <b>Underfrequency-caused power raising</b> is set to <b>Enable</b> . It specifies the transition frequency in underfrequency-caused power raising.
<b>Frequency threshold for exiting underfrequency-caused power raising</b>	This parameter is displayed when <b>Underfrequency-caused power raising</b> is set to <b>Enable</b> . It specifies the frequency threshold for exiting underfrequency-caused power raising.
<b>Frequency threshold for stopping underfrequency-caused power raising</b>	This parameter is displayed when <b>Underfrequency-caused power raising</b> is set to <b>Enable</b> . It specifies the frequency threshold for stopping underfrequency-caused power raising.
<b>Power threshold for stopping underfrequency-caused power raising</b>	This parameter is displayed when <b>Underfrequency-caused power raising</b> is set to <b>Enable</b> . It specifies the power threshold for stopping underfrequency-caused power raising.
<b>Gradient of underfrequency-caused power raising</b>	This parameter is displayed when <b>Underfrequency-caused power raising</b> is set to <b>Enable</b> . It specifies the gradient of underfrequency-caused power raising.

Parameter	Description
<b>Delay of underfrequency-caused power raising</b>	This parameter is displayed when <b>Underfrequency-caused power raising</b> is set to <b>Enable</b> . It specifies the delay of underfrequency-caused power raising.

**Table 6-21** On/Off-grid switching

Parameter	Description
<b>Off-grid mode</b>	Specifies whether to set <b>Off-grid mode</b> to <b>Enable</b> . If this parameter is set to <b>Enable</b> , the Backup Box switches to the off-grid mode after the grid fails.
<b>Backup power SOC</b>	This parameter is displayed when <b>Off-grid mode</b> is set to <b>Enable</b> . If the battery SOC reaches the value of this parameter, the batteries stop discharging to ensure that the SOC is higher than the threshold.
<b>Off-grid operating voltage</b>	This parameter is displayed when <b>Off-grid mode</b> is set to <b>Enable</b> . It specifies the operating voltage level on the AC side of the inverter in off-grid mode.
<b>On/Off-grid switching mode</b>	This parameter is displayed when <b>Off-grid mode</b> is set to <b>Enable</b> . <ul style="list-style-type: none"> <li>• <b>Automatic:</b> After the grid power fails, the device switches to the off-grid mode. After the grid power recovers, the device switches to the on-grid mode.</li> <li>• <b>Manual:</b> The device is manually switched between the on-grid mode and the off-grid mode.</li> </ul>
<b>Switch to off-grid</b>	This parameter is displayed when <b>On/Off-grid switching mode</b> is set to <b>Manual</b> . It specifies whether to enable manual switching to the off-grid mode.

**Table 6-22** Power adjustment

Parameter	Description
<b>Remote power scheduling</b>	Specifies whether to set <b>Remote power scheduling</b> to <b>Enable</b> . If this parameter is set to <b>Enable</b> , the inverter responds to the scheduling command from the remote port. If this parameter is set to <b>Disable</b> , the inverter does not respond to the scheduling command from the remote port.
<b>Power Factor</b>	This parameter is displayed when <b>Remote power scheduling</b> is set to <b>Enable</b> . It specifies the power factor of the inverter.

Parameter	Description
<b>Active power (%)</b>	This parameter is displayed when <b>Remote power scheduling</b> is set to <b>Enable</b> . It specifies the active power (%).
<b>Active power derating (%)</b>	This parameter is displayed when <b>Remote power scheduling</b> is set to <b>Enable</b> . It is used to adjust the active output power of the inverter by percentage.
<b>Active power (kW)</b>	This parameter is displayed when <b>Remote power scheduling</b> is set to <b>Enable</b> . It specifies the active power (kW).
<b>Fixed active power derated</b>	This parameter is displayed when <b>Remote power scheduling</b> is set to <b>Enable</b> . It is used to adjust the active power output of the inverter by fixed value.
<b>Reactive power change gradient</b>	This parameter is displayed when <b>Remote power scheduling</b> is set to <b>Enable</b> . It specifies the reactive power change gradient.
<b>Active power change gradient</b>	This parameter is displayed when <b>Remote power scheduling</b> is set to <b>Enable</b> . It specifies the active power change gradient.
<b>Reactive power compensation (Q/S)</b>	This parameter is displayed when <b>Remote power scheduling</b> is set to <b>Enable</b> . It specifies the reactive power output by the inverter.
<b>Reactive power percentage (Q/S) (0.01%)</b>	This parameter is displayed when <b>Remote power scheduling</b> is set to <b>Enable</b> . It specifies the reactive power (%).
<b>Fast power scheduling</b>	Specifies whether to set <b>Fast power scheduling</b> to <b>Enable</b> .
<b>No-load power calibration</b>	Specifies the energy source for the standby loss in the scenario with no power under grid dispatching.
<b>Schedule instruction valid duration</b>	Specifies the validity period of the scheduling instruction. If this parameter is set to <b>0</b> , the scheduling instruction is effective permanently.
<b>Plant active power gradient</b>	Specifies the rate of active power rise due to irradiance changes.
<b>Filtering time of the average active power of the plant</b>	Specifies the period of active power rise due to irradiance changes.

Parameter	Description
<b>Night-time reactive power</b>	This parameter is displayed when <b>Isolation setting</b> is set to <b>Input not grounded, with a transformer</b> . It specifies whether to set <b>Night-time reactive power</b> to <b>Enable</b> . In some specific application scenarios, a power grid company requires that the device can perform reactive power compensation at night to ensure that the power factor of the local power grid meets requirements.
<b>Apply nighttime reactive power parameters</b>	This parameter is displayed when <b>Night-time reactive power</b> is set to <b>Enable</b> . It specifies whether to set <b>Apply nighttime reactive power parameters</b> to <b>Enable</b> .
<b>Fixed nighttime reactive power</b>	This parameter is displayed when <b>Apply nighttime reactive power parameters</b> is set to <b>Enable</b> . If no remote scheduling instruction is received, the reactive power is supplied based on this parameter.
<b>Insulation resistance inspection during reactive power output at night</b>	This parameter is displayed when <b>Night-time reactive power</b> is set to <b>Enable</b> . It specifies whether to set <b>Insulation resistance inspection during reactive power output at night</b> to <b>Enable</b> . If this parameter is set to <b>Enable</b> , the device automatically detects the status every night. During the detection, the device automatically resets.
<b>Reactive power compensation at night (Q/S)</b>	During the reactive power compensation at night, the reactive power is scheduled by percentage.

Table 6-23 Voltage rise suppression

Parameter	Description
<b>Voltage rise suppression</b>	Specifies whether to set <b>Voltage rise suppression</b> to <b>Enable</b> . The standards of certain countries and regions require that the inverter suppress voltage rise by outputting reactive power and reducing active power when the output voltage exceeds a certain value.
<b>Reactive power adjustment threshold for voltage rise suppression</b>	This parameter is displayed when <b>Voltage rise suppression</b> is set to <b>Enable</b> . It specifies the reactive power adjustment threshold for voltage rise suppression.
<b>Active power derating threshold for voltage rise suppression</b>	This parameter is displayed when <b>Voltage rise suppression</b> is set to <b>Enable</b> . It specifies the active power adjustment threshold for voltage rise suppression.

**Table 6-24** Power baseline

Parameter	Description
<b>apparent power reference</b>	Specifies the apparent power baseline for power scheduling. The value cannot be greater than <b>Maximum apparent power</b> .
<b>Active power reference</b>	Specifies the active power baseline for power scheduling. The value cannot be greater than <b>Maximum active power</b> .
<b>Maximum apparent power</b>	Specifies the output upper threshold for the maximum apparent power to adapt to the capacity requirements of standard and customized inverters.
<b>Maximum active power</b>	Specifies the output upper threshold for the maximum active power to adapt to different market requirements.
<b>Maximum overload active power</b>	Specifies the maximum overload active power for grid forming.
<b>Maximum overload apparent power</b>	Specifies the maximum overload apparent power for grid forming.

**Table 6-25** AFCI

Parameter	Description
<b>AFCI</b>	The North American standard requires that the device provide the DC arc detection function. The parameter specifies whether to set <b>AFCI</b> to <b>Enable</b> .
<b>AFCI detection mode</b>	This parameter is displayed when <b>AFCI</b> is set to <b>Enable</b> . The parameter is used to adjust the sensitivity of arc detection.
<b>AFCI self-check</b>	Starts an AFCI self-check.

**Table 6-26** MPPT configuration

Parameter	Description
<b>MPPT multi-peak scanning</b>	Specifies whether to set <b>MPPT multi-peak scanning</b> to <b>Enable</b> . When the inverter is used in scenarios where PV strings are obviously shaded, set this parameter to <b>Enable</b> , and then the inverter will perform global MPPT scanning at regular intervals to locate the maximum power.

Parameter	Description
<b>MPPT scanning interval</b>	This parameter is displayed when <b>MPPT multi-peak scanning</b> is set to <b>Enable</b> . It specifies the MPPT scanning interval.

**Table 6-27** RCD configuration

Parameter	Description
<b>RCD enhancement</b>	Specifies whether to set <b>RCD enhancement</b> to <b>Enable</b> . If an AC switch with a residual current detection function is installed outside the inverter, set this function to <b>Enable</b> to reduce the residual current generated when the inverter is running, thereby preventing the AC switch from misoperations.
<b>RCD current limit</b>	This parameter is displayed when <b>RCD enhancement</b> is set to <b>Enable</b> . It specifies the RCD current limit.
<b>Current threshold for triggering RCD protection</b>	An RCD is an electrical safety device that detects leakage current in a circuit and quickly cuts off the circuit when an exception is detected. If this parameter is set to a small value, the device may frequently trigger the protection mechanism. Set this parameter with caution. If you have any question, contact technical support.

**Table 6-28** Output impedance enhancement

Parameter	Description
<b>Output impedance enhancement</b>	Specifies whether to set <b>Output impedance enhancement</b> to <b>Enable</b> .
<b>Frequency to which output impedance enhancement applies</b>	This parameter is displayed when <b>Output impedance enhancement</b> is set to <b>Enable</b> . It specifies the frequency to which output impedance enhancement applies.

Table 6-29 PV string detection

Parameter	Description
<b>Smart string monitoring</b>	Specifies whether to set <b>Smart string monitoring</b> to <b>Enable</b> . The inverter monitors PV strings in real time. If any PV string is abnormal (for example, the PV string is shaded or the energy yield decreases), the inverter generates an alarm to remind maintenance personnel to maintain the PV string in a timely manner. If PV strings are often shaded, you are advised to set <b>Smart string monitoring</b> to <b>Disable</b> to prevent false alarms.
<b>Reference asymmetric coefficient for string detection</b>	This parameter is displayed when <b>Smart string monitoring</b> is set to <b>Enable</b> . It specifies the threshold for determining PV string abnormalities to control false alarms caused by fixed shading.
<b>Startup power percentage for string detection</b>	This parameter is displayed when <b>Smart string monitoring</b> is set to <b>Enable</b> . It specifies the threshold for starting to detect PV string abnormalities to control false alarms caused by fixed shading.

Table 6-30 JET parameters

Parameter	Description
<b>Frequency feedback module</b>	Specifies whether to set <b>Frequency feedback module</b> to <b>Enable</b> .
<b>Step injection module</b>	Specifies whether to set <b>Step injection module</b> to <b>Enable</b> .
<b>AC overvoltage protection</b>	Specifies whether to set <b>AC overvoltage protection</b> to <b>Enable</b> .
<b>K1 value of frequency feedback module</b>	Specifies the K1 value of the frequency feedback module.
<b>K2 value of frequency feedback module</b>	Specifies the K2 value of the frequency feedback module.
<b>Reactive power oscillation damping</b>	Specifies whether to set <b>Reactive power oscillation damping</b> to <b>Enable</b> .
<b>Normal/Standby state switching</b>	This parameter is displayed when <b>Reactive power oscillation damping</b> is set to <b>Enable</b> . You can manually switches between <b>Normal</b> and <b>Standby</b> .
<b>Restart delay after grid failure</b>	Specifies the restart delay after grid failure.

Parameter	Description
<b>Reactive control voltage for voltage rise suppression</b>	Specifies the reactive control voltage for voltage rise suppression.
<b>Active control voltage for voltage rise suppression</b>	Specifies the active control voltage for voltage rise suppression.

**Table 6-31** Protection upon communication failure

Parameter	Description
<b>Shutdown upon communication failure</b>	Specifies whether to set <b>Shutdown upon communication failure</b> to <b>Enable</b> . The device will shut down when communication has been interrupted beyond the duration specified by <b>Shutdown duration during communication failure</b> .
<b>Startup upon communication recovery</b>	This parameter is displayed when <b>Shutdown upon communication failure</b> is set to <b>Enable</b> . It specifies whether to set <b>Startup upon communication recovery</b> to <b>Enable</b> . If this parameter is set to <b>Enable</b> , the device automatically starts after the communication recovers.
<b>Shutdown duration during communication failure</b>	The device will shut down when communication has been interrupted beyond the duration specified by <b>Shutdown duration during communication failure</b> .
<b>Protection upon Communication Failure</b>	Specifies whether to set <b>Protection upon Communication Failure</b> to <b>Enable</b> . If this parameter is set to <b>Enable</b> , the device performs protection based on the preset power when it fails to communicate with the SmartMGC.
<b>Communication disconnection duration</b>	This parameter is displayed when <b>Protection upon Communication Failure</b> is set to <b>Enable</b> . If communication between the inverter and the SmartMGC is interrupted beyond the duration specified by this parameter, it is considered as a failure.
<b>Failure protection active power mode</b>	This parameter is displayed when <b>Protection upon Communication Failure</b> is set to <b>Enable</b> . It specifies the active power mode adopted when communication fails.
<b>Active power limit when communication fails</b>	Specifies the active power limit when communication fails.

Parameter	Description
<b>Failure protection reactive power mode</b>	This parameter is displayed when <b>Protection upon Communication Failure</b> is set to <b>Enable</b> . It specifies the reactive power mode adopted when communication fails.
<b>Reactive power limit when communication fails</b>	Specifies the reactive power limit when communication fails.
<b>Rapid shutdown if inverter communication fails</b>	Specifies whether to set <b>Rapid shutdown if inverter communication fails</b> to <b>Enable</b> .
<b>Duration for triggering rapid shutdown if communication fails</b>	Specifies the duration for triggering rapid shutdown if communication fails.

**Table 6-32** PV string access detection

Parameter	Description
<b>PV string access detection</b>	Specifies whether to set <b>PV string access detection</b> to <b>Enable</b> .
<b>Startup current</b>	<p>When the current of all connected PV strings reaches the preset value, the PV string access detection function is enabled.</p> <p><b>NOTE</b> Startup current setting rules:</p> <ul style="list-style-type: none"> <li>Startup current = <math>I_{sc} (S_{TC}) \times 0.6</math> (rounded up). For details about <math>I_{sc} (S_{TC})</math>, see the PV module nameplate.</li> <li>Default startup current (5 A): applicable to the scenarios where the short-circuit current <math>I_{sc} (S_{TC})</math> is greater than 8 A for the monocrystalline and polycrystalline PV modules.</li> </ul>
<b>Startup current for 2-in-1 detection</b>	The default value is recommended. When the current of a PV string reaches the threshold specified by this parameter, the PV string is automatically identified as 2-in-1.
<b>PV module nameplate short-circuit current</b>	Specifies the short-circuit current on the PV module nameplate.

Parameter	Description
<b>PV string <math>a</math> access type<sup>[1]</sup></b>	Set this parameter based on the type of the PV string connected to DC input terminal $a$ of the inverter. The default value is recommended. If the value is incorrectly set, the PV string access type may be incorrectly identified and false alarms may be generated for the PV string access status.
[1]: $a$ is the DC input terminal number of the inverter.	

**Table 6-33** Energy adjustment

Parameter	Description
<b>Adjusted total energy yield</b>	A calibrating coefficient for the total energy yield to ensure that the reported energy yield is consistent with the actual energy yield at the grid-connection point
<b>Adjusted total power supply from grid</b>	A calibrating coefficient for the total power supply from the grid to ensure that the reported amount of power supplied from the grid is consistent with the actual power supply at the grid connection point

**Table 6-34** O&M configuration

Parameter	Description
<b>Safe mode</b>	Specifies whether to enable the safe mode.
<b>Update via USB</b>	Specifies whether to set <b>Update via USB</b> to <b>Enable</b> .
<b>USB Wakeup</b>	Used to remotely wake up the USB O&M port. After being idle for 4 hours, the port is automatically disabled.
<b>O&amp;M via USB connection</b>	Specifies the policy of O&M via USB connection.
<b>Delayed upgrade</b>	Specifies whether to set <b>Delayed upgrade</b> to <b>Enable</b> . This parameter is mainly used in the upgrade scenarios where the PV power supply is disconnected at night due to no sunlight or is unstable at dawn or dusk due to weak sunlight. If this parameter is set to <b>Enable</b> , the device loads the upgrade package after the upgrade starts. After the PV power supply becomes normal and the activation conditions are met, the device automatically completes the activation process.
<b>Upgrade rollback prevention</b>	Specifies whether to set <b>Upgrade rollback prevention</b> to <b>Enable</b> . If this parameter is set to <b>Enable</b> , the version cannot be rolled back during a software upgrade.

Parameter	Description
<b>WLAN wakeup</b>	Wakes up the WLAN.
<b>O&amp;M via WLAN connection</b>	Specifies the policy of O&M via WLAN connection.
<b>Fault recording</b>	Specifies whether to set <b>Fault recording</b> to <b>Enable</b> .
<b>Recording by Command</b>	Specifies whether to set <b>Recording by Command</b> to <b>Enable</b> .
<b>Validity period of recording by command</b>	After a remote scheduling command is received within the specified period, the 2s waveform data is recorded immediately.

## Characteristic curve

If the remote reactive power control command is unavailable, the SmartMGC provides the characteristic curve configuration function as a substitute. After the SmartMGC delivers the characteristic curve configuration to the device, the device executes the configuration, and the SmartMGC does not implement adjustment.

### NOTE

Path: **Monitoring > Inverter > Characteristic Curve**

- **Q-U characteristic curve**

In the Q-U characteristic curve control mode, the device dynamically adjusts the ratio  $Q/S$  of output reactive power to apparent power in accordance with the ratio  $U/U_n$  of the actual grid voltage to the rated grid voltage.

**Table 6-35** Q-U characteristic curve

Parameter	Description
<b>Q-U characteristic curve mode</b>	Specifies the Q-U characteristic curve mode.
<b>Reactive power adjustment time</b>	Specifies the change interval of the reactive power at the grid connection point.
<b>Q-U scheduling triggering power percentage</b>	Under a specific grid code, the characteristic curve takes effect only when the actual output active power of the device is greater than the specified value.
<b>Q-U Scheduling Exit Power Percentage</b>	Under a specific grid code, the characteristic curve becomes invalid only when the actual output active power of the device is less than the specified value.

Parameter	Description
<b>Q-U characteristic curve minimum PF limit</b>	Limits the actual minimum PF when the Q-U characteristic curve takes effect.
<b>Q-U curve delay time</b>	Specifies the delay time for the Q-U characteristic curve to take effect.
<b>Q-U characteristic curve setting</b>	Set this parameter as required. When configuring the curve, ensure that the <b>U/Un</b> value of a point is greater than the <b>U/Un</b> value of the previous point.
<b>U/Un</b>	
<b>Q/S</b>	

- **cosφ-P/Pn characteristic curve**

In the cosφ-P/Pn characteristic curve control mode, the device dynamically adjusts the power factor **cosφ** in accordance with the **P/Pn** based on the VDE-4105 and BDEW German standards.

**Table 6-36** cosφ-P/Pn characteristic curve

Parameter	Description
<b>Reactive power adjustment time</b>	Time for the reactive power to reach the target value.
<b>cosφ-P/Pn trigger voltage</b>	Specifies the voltage for triggering the cosφ-P/Pn characteristic curve.
<b>cosφ-P/Pn exit voltage</b>	Specifies the voltage for exiting the cosφ-P/Pn characteristic curve.
<b>cosφ-P/Pn characteristic curve setting</b>	Set this parameter as required. When configuring the curve, ensure that the <b>P/Pn</b> value of a point is greater than the <b>P/Pn</b> value of the previous point.
<b>P/Pn</b>	
<b>cosφ</b>	

- **PF-U characteristic curve**

In the PF-U characteristic curve control mode, the device dynamically adjusts the **U/Un** at the device port based on the ratio **U/Un** of the actual grid voltage to the rated grid voltage.

**Table 6-37** PF-U characteristic curve

Parameter	Description
<b>PF-U characteristic curve setting</b>	Set this parameter as required. When configuring the curve, ensure that the <b>U/Un</b> value of a point is greater than the <b>U/Un</b> value of the previous point.
<b>U/Un</b>	
<b>French Polynesia</b>	

- **Q-P characteristic curve**

In the Q-P characteristic curve control mode, the device adjusts the ratio **Q/Pn** of the output reactive power to the rated power based on the ratio **P/Pn** of the current active power to the rated power.

**Table 6-38** Q-P characteristic curve

Parameter	Description
<b>Reactive power adjustment time</b>	Time for the reactive power to reach the target value.
<b>Q-P characteristic curve setting</b>	Set this parameter as required. When configuring the curve, ensure that the <b>P/Pn</b> value of a point is greater than the <b>P/Pn</b> value of the previous point.
<b>P/Pn</b>	
<b>Q/Pn</b>	

- **LVRT characteristic curve**

**Table 6-39** LVRT characteristic curve

Parameter	Description
<b>LVRT Characteristic Curve</b>	Set these parameters as required. When configuring the curve, ensure that the <b>t</b> value of a point is greater than the <b>t</b> value of the previous point.
<b>t</b>	
<b>U/Uc</b>	

- **HVRT characteristic curve**

**Table 6-40** HVRT characteristic curve

Parameter	Description
HVRT Characteristic Curve	Set these parameters as required. When configuring the curve, ensure that the <b>t</b> value of a point is greater than the <b>t</b> value of the previous point.
t	
U/Uc	

## Performance Data

On the performance data page, you can click **Export** to export device performance data.

### 6.4.3 ESS

#### Running Parameters

 NOTE

Path: **Monitoring > ESS > Running Parameters**

**Table 6-41** System configuration

Parameter	Description
Microgrid compatibility	<ul style="list-style-type: none"> <li><b>Disable:</b> Set this parameter to <b>Disable</b> when <b>Working Mode</b> is set to <b>VSG</b> or <b>Scenario</b> is set to <b>On-grid</b>.</li> <li><b>Enable:</b> If <b>Working Mode</b> is set to <b>PQ</b> for the device and the device works in a microgrid that uses a diesel generator or other voltage sources, set this parameter to <b>Enable</b>. If this parameter is set to <b>Enable</b>, the device adaptively changes the output power based on the original grid code and the grid voltage and frequency to support a higher ratio of current sources to voltage sources (that is, PV-to-ESS ratio).</li> </ul>
shutdown gradient	Specifies the power change rate until the device shuts down.
Dust removal by reverse rotation	Specifies whether to enable dust removal by reverse rotation based on site requirements.
Dust removal interval	Specifies the dust removal interval.
Harmonic optimization type	Specifies the object of power quality optimization. You can set this parameter to <b>Harmonic voltage</b> or <b>Harmonic current</b> .

Parameter	Description
<b>Activate balancing module</b>	Specifies whether to activate the balancing module.
<b>Forced dehumidification control</b>	Start forced dehumidification. You are advised to start forced dehumidification when starting the device for the first time or after the device has been stored for a long time to reduce the risk of device damage due to condensation.
<b>Burglar alarm horn/strobe</b>	Specifies whether to set <b>Burglar alarm horn/strobe</b> to <b>Enable</b> . If this parameter is set to <b>Enable</b> , the burglar alarm function of the ESS is enabled. Opening the ESS door will trigger the alarm horn/strobe.
<b>Exhaust function self-test</b>	After the self-test is started, the exhaust fan will be running for a period of time to check its exhaust function. If the exhaust fan does not meet the requirements, the system cannot start.
<b>Exhaust fan control</b>	<ul style="list-style-type: none"> <li>● <b>Start:</b> Start the exhaust fan. It will run for at least one hour and then stop automatically.</li> <li>● <b>Stop:</b> Stop the exhaust fan. If a flammable gas alarm is generated, the exhaust fan cannot be stopped.</li> </ul> <p><b>NOTE</b> The exhaust fan cannot be manually started within 24 hours after the fire response is triggered (unless the fire alarm is cleared).</p>
<b>Soft start time</b>	Specifies the duration for the power to gradually increase until the device starts.
<b>Alarm horn/strobe control</b>	<ul style="list-style-type: none"> <li>● <b>Stop:</b> The alarm horn/strobe of the ESS is disabled.</li> <li>● <b>Start:</b> The alarm horn/strobe of the ESS is enabled.</li> </ul>
<b>Threshold for active balancing</b>	When the cell pressure difference between packs reaches the threshold, the active balancing management logic is triggered.
<b>Exhaust function self-test time</b>	Specifies the time when the exhaust function is self-tested every day.
<b>Battery rack insulation resistance protection threshold</b>	Specifies the insulation resistance protection threshold.

Parameter	Description
<b>TRSD backup power supply</b>	This parameter is displayed only when the TRSD backup power supply is available. It specifies whether to set <b>TRSD backup power supply</b> to <b>Enable</b> . The thermal runaway suppression device (TRSD) uses lead-acid batteries as the backup power supply. If the primary power supply is disconnected and switched to the backup power supply, the energy of the lead-acid batteries may be exhausted. To reduce the probability of this risk, an external port for operating the backup power switch is added.
<b>Replace end-of-life sensor</b>	Set this parameter after sensor replacement is completed.

**Table 6-42** Cooling system

Parameter	Description
<b>Silent mode</b>	If the silent mode is enabled, the noise of the entire cabinet can be reduced.
<b>Maintenance mode</b>	<ul style="list-style-type: none"> <li>• <b>Standby:</b> Wait for refilling coolant into or draining coolant from the liquid cooling pipe system.</li> <li>• <b>Filling coolant:</b> Fill coolant into the liquid cooling pipe system.</li> <li>• <b>Draining coolant:</b> Drain coolant from the liquid cooling pipe system.</li> </ul>
<b>Diagnostic mode</b>	<ul style="list-style-type: none"> <li>• <b>Manual:</b> Some components of the LTMS are manually controlled.</li> <li>• <b>Automatic:</b> The status of the LTMS is checked automatically.</li> </ul>
<b>Maximum diagnostic mode duration</b>	The system automatically exits the diagnostic mode when the specified duration is reached.
<b>Battery temperature control mode for diagnosis</b>	This parameter is displayed when <b>Diagnostic mode</b> is set to <b>Manual</b> . It is used to diagnose the functions of the components involved in different battery temperature control modes.
<b>Internal environment dehumidifying control mode for diagnosis</b>	This parameter is displayed when <b>Diagnostic mode</b> is set to <b>Manual</b> . If this parameter is set to <b>Started</b> , the dehumidification function is enabled to diagnose the functions of components involved in the dehumidification function.

Parameter	Description
<b>Internal environment temperature control mode for diagnosis</b>	This parameter is displayed when <b>Diagnostic mode</b> is set to <b>Manual</b> . <ul style="list-style-type: none"><li>● <b>Passive cooling</b>: The passive cooling function is enabled to diagnose the functions of components involved in passive cooling.</li><li>● <b>Active cooling</b>: The active cooling function is enabled to diagnose the functions of components involved in active cooling.</li></ul>
<b>Liquid cooling mode</b>	<ul style="list-style-type: none"><li>● <b>Automatic mode</b>: Automatically control the running of the LTMS.</li><li>● <b>Diagnostic mode</b>: Diagnose the LTMS running status.</li><li>● <b>Maintenance mode</b>: Choose this mode when coolant needs to be refilled or drained.</li></ul>
<b>Battery temperature adjustment</b>	Specifies the battery temperature adjustment mode.
<b>Confirm coolant replacement</b>	If the coolant needs to be replaced, set this parameter and click <b>Submit</b> .
<b>Coolant replacement interval</b>	Specifies the coolant replacement interval.
<b>Power limit function for liquid cooling</b>	If the power limit function for liquid cooling is enabled, the operating power of the LMTS can be limited.
<b>Setting status of electric heater</b>	This parameter is displayed when <b>Liquid cooling mode</b> is set to <b>Diagnostic mode</b> , <b>Diagnostic mode</b> is set to <b>Manual</b> , and <b>Battery temperature control mode for diagnosis</b> is set to <b>Hybrid heating</b> or <b>Electric heating</b> . It specifies whether to set <b>Setting status of electric heater</b> to <b>Enable</b> .
<b>Setting status of compressor 1</b>	Controls the compressor speed.
<b>Dehumidification fan setting status</b>	Controls the dehumidification fan speed.
<b>Setting status of outdoor fan 1</b>	Controls the outdoor fan speed.
<b>Setting status of outdoor fan 2</b>	Controls the outdoor fan speed.
<b>Setting status of circulating pump 1</b>	Controls the circulating pump speed.

Parameter	Description
Setting status of circulating pump 2	Controls the circulating pump speed.
Clear total runtime of electric heater	To recalculate the total runtime of the electric heater, set this parameter and click <b>Submit</b> .
Clear total air filter usage duration	To recalculate the total usage duration of the air filter, set this parameter and click <b>Submit</b> .
Clear total switching times of multi-way valve	To recalculate the total switching times of the multi-way valve, set this parameter and click <b>Submit</b> .
Clear total runtime of compressor 1	To recalculate the total runtime of the compressor, set this parameter and click <b>Submit</b> .
Clear total runtime of dehumidifying fan	To recalculate the total runtime of the dehumidifying fan, set this parameter and click <b>Submit</b> .
Clear total runtime of circulating pump 1	To recalculate the total runtime of the circulating pump, set this parameter and click <b>Submit</b> .
Clear total runtime of circulating pump 2	To recalculate the total runtime of the circulating pump, set this parameter and click <b>Submit</b> .
Clear total runtime of outdoor fan 1	To recalculate the total runtime of the outdoor fan, set this parameter and click <b>Submit</b> .
Clear total runtime of outdoor fan 2	To recalculate the total runtime of the outdoor fan, set this parameter and click <b>Submit</b> .
Clear total runtime of EEV 1	To recalculate the total runtime of the EEV, set this parameter and click <b>Submit</b> .
Clear total runtime of EEV 2	To recalculate the total runtime of the EEV, set this parameter and click <b>Submit</b> .

Table 6-43 Working mode

Parameter	Description
Working Mode	Specifies the working mode of the device based on the actual scenario.

Parameter	Description
<b>Auto switching between working modes</b>	<ul style="list-style-type: none"> <li>• <b>Disable:</b> On/Off-grid switching cannot be performed automatically.</li> <li>• <b>Enable:</b> On/Off-grid switching can be performed automatically and the device does not need to be shut down before the switching.</li> </ul>
<b>Working mode switching interval</b>	Specifies the time for other instructions to take effect during device working mode switching.
<b>Working mode switching delay</b>	Specifies the delay for the working mode switching to take effect.
<b>Zero-sequence overvoltage threshold for grid-tied and off-grid switching</b>	Specifies the zero-sequence overvoltage threshold for on/off-grid switching.
<b>PQ/VSG auto switching interval</b>	Specifies the time during which the device is not allowed to automatically switch to the VSG mode after it is manually switched to the PQ mode.
<b>Voltage drop for auto switching to level-1 working mode</b>	Specifies the voltage drop threshold for triggering automatic working mode switching.
<b>Voltage drop delay for auto switching to level-1 working mode</b>	Specifies the duration during which the voltage drop must be maintained after the voltage drop reaches the level-1 voltage drop threshold. The working mode will be switched if the requirement is met.
<b>Voltage drop for auto switching to level-1 working mode</b>	Specifies the voltage drop threshold for triggering automatic working mode switching.

**Table 6-44** Grid parameters

Parameter	Description
<b>Grid code</b>	Set this parameter based on the grid code of the country or region where the device is located and the application scenario of the device.
<b>Voltage level</b>	Specifies the voltage level of the power grid.
<b>Frequency level</b>	Specifies the frequency level of the power grid.

Parameter	Description
<b>Isolation setting</b>	Set the working mode of the device based on the grounding status on the DC side and the connection to the power grid.
<b>Output mode</b>	Set the output mode based on the actual cable connection.
<b>Auto start upon grid recovery</b>	<ul style="list-style-type: none"> <li>• <b>Enable:</b> The inverter automatically starts when the power grid recovers from a fault or outage.</li> <li>• <b>Disable:</b> The inverter does not automatically start when the power grid recovers from a fault or outage. The inverter starts only after a startup command is delivered</li> </ul>
<b>Grid connection delay after grid recovery</b>	Specifies the delay period before device restart following grid recovery.
<b>Short-term power grid interruption and quick start</b>	<ul style="list-style-type: none"> <li>• <b>Disable:</b> After the power grid recovers from a short-time disconnection, the system connects to the power grid by following the normal startup process.</li> <li>• <b>Enable:</b> After the power grid recovers from a short-time disconnection, certain detection items are skipped to achieve quick connection to the power grid.</li> </ul>
<b>Time for determining short-time power grid interruption</b>	This parameter is displayed when <b>Short-term power grid interruption and quick start</b> is set to <b>Enable</b> . The parameter specifies the duration for determining whether the grid is disconnected for a short time. A short-time grid disconnection is determined by checking whether the power grid can recover within the period specified by <b>Time for determining short-time power grid interruption</b> .
<b>Power-on soft start time due to power grid faults</b>	Specifies the time for the power to gradually increase when the device restarts after the power grid recovers.
<b>Automatic voltage control for extremely weak grid</b>	Specifies whether to set <b>Automatic voltage control for extremely weak grid</b> to <b>Enable</b> . If this parameter is set to <b>Enable</b> , the device can run stably in an extremely weak power grid. However, the power response speed will decrease, affecting the closed-loop control effect of the array. Set this parameter with caution.
<b>Maximum grid voltage for grid reconnection</b>	After the device is shut down due to a fault, it cannot reconnect to the power grid if the grid voltage is higher than the value of this parameter.
<b>Minimum grid voltage for grid reconnection</b>	After the device is shut down due to a fault, it cannot reconnect to the power grid if the grid voltage is lower than the value of this parameter.

Parameter	Description
<b>Maximum grid frequency for grid reconnection</b>	After the device is shut down due to a fault, it cannot reconnect to the power grid if the grid frequency is higher than the value of this parameter.
<b>Minimum grid frequency for grid reconnection</b>	After the device is shut down due to a fault, it cannot reconnect to the power grid if the grid frequency is lower than the value of this parameter.
<b>Maximum grid voltage for grid connection</b>	When the device is started for the first time for grid connection, it cannot connect to the power grid if the grid voltage is higher than the value of this parameter.
<b>Minimum grid voltage for grid connection</b>	When the device is started for the first time for grid connection, it cannot connect to the power grid if the grid voltage is lower than the value of this parameter.
<b>Maximum grid frequency for grid connection</b>	When the device is started for the first time for grid connection, it cannot connect to the power grid if the grid frequency is higher than the value of this parameter.
<b>Minimum grid frequency for grid connection</b>	When the device is started for the first time for grid connection, it cannot connect to the power grid if the grid frequency is lower than the value of this parameter.
<b>Power grid automatic reconnection time</b>	Specifies the delay period before device restart following grid recovery.
<b>Voltage rise suppression</b>	Specifies whether to set <b>Voltage rise suppression</b> to <b>Enable</b> . The standards of certain countries and regions require that the inverter suppress voltage rise by outputting reactive power and reducing active power when the output voltage exceeds a certain value.
<b>Reactive power adjustment threshold for voltage rise suppression</b>	This parameter is displayed when <b>Voltage rise suppression</b> is set to <b>Enable</b> . It specifies the reactive power adjustment threshold for voltage rise suppression.
<b>Active power derating threshold for voltage rise suppression</b>	This parameter is displayed when <b>Voltage rise suppression</b> is set to <b>Enable</b> . It specifies the active power adjustment threshold for voltage rise suppression.

**Table 6-45** Protection configuration

Parameter	Description
<b>Phase protection threshold</b>	The Japanese standard requires that during passive islanding, protection be triggered if an abrupt voltage phase change is detected.

Parameter	Description
<b>Phase angle offset protection</b>	Specifies whether to set <b>Auto recovery from string-to-ground short-circuit protection</b> to <b>Enable</b> . Protection is triggered if the phase angle offset of the three phases of the power grid exceeds a certain value.
<b>Active Islanding Protection</b>	Specifies whether to set <b>Active Islanding Protection</b> to <b>Enable</b> .
<b>Passive island protection</b>	Specifies whether to set <b>Enable</b> to <b>Enable</b> .
<b>Voltage imbalance protection threshold</b>	Specifies the threshold for device protection when the power grid voltage is unbalanced.
<b>PCS insulation resistance protection threshold</b>	To ensure device safety, the device detects the insulation resistance of the DC side to the ground when it starts a self-check. If the detected value is less than the preset value, the device does not start.
<b>Frequency Rate Change Protection</b>	Specifies whether to set <b>Frequency Rate Change Protection</b> to <b>Enable</b> . If the function is enabled, the device triggers protection when the power grid frequency changes too fast.
<b>Frequency change rate protection threshold</b>	This parameter is displayed when <b>Frequency Rate Change Protection</b> is set to <b>Enable</b> . It specifies the frequency change rate protection threshold.
<b>Duration threshold for frequency change rate protection</b>	This parameter is displayed when <b>Frequency Rate Change Protection</b> is set to <b>Enable</b> . It specifies the frequency change rate protection duration.

Table 6-46 Overvoltage protection

Parameter	Description
<b>10-minute overvoltage protection threshold</b>	Specifies the 10-minute overvoltage protection threshold.
<b>Duration threshold for 10-minute overvoltage protection</b>	Specifies the duration threshold for 10-minute overvoltage protection.

Parameter	Description
<b>Level <math>\alpha</math> overvoltage protection threshold<sup>[1]</sup></b>	Level $\alpha$ overvoltage protection threshold $\leq$ Level $\alpha+1$ overvoltage protection threshold
<b>Duration threshold for level <math>\alpha</math> overvoltage protection<sup>[1]</sup></b>	Duration threshold for level $\alpha$ overvoltage protection $\geq$ Duration threshold for level $\alpha+1$ overvoltage protection
<b>Off-grid level-<math>\beta</math> overvoltage protection threshold<sup>[2]</sup></b>	Specifies the off-grid overvoltage protection threshold.
<b>Duration threshold for off-grid level-<math>\beta</math> overvoltage protection<sup>[2]</sup></b>	Specifies the duration threshold for off-grid $\beta$ -level overvoltage protection.
[1]: $\alpha = 1-6$ [2]: $\beta = 1-4$	

**Table 6-47** Undervoltage protection

Parameter	Description
<b>Ten-minute undervoltage protection threshold</b>	Specifies the 10-minute undervoltage protection threshold.
<b>10 minutes undervoltage protection time</b>	Specifies the duration threshold for 10-minute undervoltage protection.
<b>Level <math>\alpha</math> undervoltage protection threshold<sup>[1]</sup></b>	Level $\alpha$ undervoltage protection threshold $\geq$ Level $\alpha+1$ undervoltage protection threshold
<b>Duration threshold for level <math>\alpha</math> undervoltage protection<sup>[1]</sup></b>	Duration threshold for level $\alpha$ undervoltage protection $\geq$ Duration threshold for level $\alpha+1$ undervoltage protection

Parameter	Description
<b>Off-grid level-β undervoltage protection threshold<sup>[2]</sup></b>	Specifies the off-grid undervoltage protection threshold.
<b>Duration threshold for off-grid level-β undervoltage protection<sup>[2]</sup></b>	Specifies the duration threshold for off-grid undervoltage protection.
[1]: α = 1-6 [2]: β = 1-4	

**Table 6-48** Overfrequency protection

Parameter	Description
<b>Level α overfrequency protection threshold<sup>[1]</sup></b>	Level α overfrequency protection threshold ≤ Level α+1 overfrequency protection threshold
<b>Duration threshold for level α overfrequency protection<sup>[1]</sup></b>	Duration threshold for level α overfrequency protection ≥ Duration threshold for level α+1 overfrequency protection
<b>Off-grid level-β overfrequency protection threshold<sup>[2]</sup></b>	Specifies the off-grid overfrequency protection threshold.
<b>Duration threshold for off-grid level-β overfrequency protection<sup>[2]</sup></b>	Specifies the duration threshold for off-grid overfrequency protection.
[1]: α = 1-6 [2]: β = 1-4	

**Table 6-49** Underfrequency protection

Parameter	Description
<b>Level <math>\alpha</math> underfrequency protection threshold<sup>[1]</sup></b>	Level $\alpha$ underfrequency protection threshold $\geq$ Level $\alpha+1$ underfrequency protection threshold
<b>Duration threshold for level <math>\alpha</math> underfrequency protection<sup>[1]</sup></b>	Duration threshold for level $\alpha$ underfrequency protection $\geq$ Duration threshold for level $\alpha+1$ underfrequency protection
<b>Off-grid level-<math>\beta</math> underfrequency protection threshold<sup>[2]</sup></b>	Specifies the off-grid underfrequency protection threshold.
<b>Duration threshold for off-grid level-<math>\beta</math> underfrequency protection<sup>[2]</sup></b>	Specifies the duration threshold for off-grid underfrequency protection.
[1]: $\alpha = 1-6$ [2]: $\beta = 1-4$	

**Table 6-50** Grid forming control

Parameter	Description
<b>On-grid VSG inertia time constant</b>	Specifies the time required for the virtual rotor of the GFM-related virtual synchronous generator to reach the rated speed from the static state under the rated torque.
<b>Active power frequency regulation coefficient in grid forming mode</b>	This parameter is displayed when <b>Working Mode</b> is set to <b>VSG</b> . It specifies the ratio of the per unit value of the active power variation to the per unit value of the frequency variation for the frequency regulation.
<b>Reactive power voltage regulation coefficient in grid forming mode</b>	This parameter is displayed when <b>Working Mode</b> is set to <b>VSG</b> . It specifies the ratio of the per unit value of the reactive power variation to the per unit value of the root mean square voltage variation for the voltage regulation.
<b>Active power frequency regulation deadband in grid forming mode</b>	This parameter is displayed when <b>Working Mode</b> is set to <b>VSG</b> . It specifies the active power frequency regulation deadband in grid forming mode.

Parameter	Description
<b>Reactive power voltage regulation deadband in grid forming mode</b>	This parameter is displayed when <b>Working Mode</b> is set to <b>VSG</b> . It specifies the reactive power voltage regulation deadband in grid forming mode.
<b>Upper limit of active power variation for frequency regulation in grid forming mode</b>	This parameter is displayed when <b>Working Mode</b> is set to <b>VSG</b> . It specifies the maximum percentage of the active power variation for the frequency regulation. The upper limit can be set to the per unit value of <b>Active power reference</b> .
<b>Lower limit of active power variation for frequency regulation in grid forming mode</b>	This parameter is displayed when <b>Working Mode</b> is set to <b>VSG</b> . It specifies the minimum percentage of the active power variation for the frequency regulation. The lower limit can be set to the per unit value of <b>Active power reference</b> .
<b>Upper limit of reactive power variation for voltage regulation in grid forming mode</b>	This parameter is displayed when <b>Working Mode</b> is set to <b>VSG</b> . It specifies maximum percentage of the reactive power variation for the voltage regulation. The upper limit can be set to three times the per unit value of <b>apparent power reference</b> .
<b>Lower limit of reactive power variation for voltage regulation in grid forming mode</b>	This parameter is displayed when <b>Working Mode</b> is set to <b>VSG</b> . It specifies the minimum percentage of the reactive power variation for the frequency regulation. The lower limit can be set to three times the per unit value of <b>apparent power reference</b> .

Table 6-51 Off-grid control

Parameter	Description
<b>P-F adjustment coefficient</b>	This parameter is displayed when <b>Working Mode</b> is set to <b>VSG</b> . It specifies the frequency deviation corresponding to the rated active power of the virtual synchronous generator.
<b>Q-F adjustment coefficient</b>	This parameter is displayed when <b>Working Mode</b> is set to <b>VSG</b> . It specifies the frequency deviation corresponding to the rated reactive power of the virtual synchronous generator.
<b>P-V adjustment coefficient</b>	This parameter is displayed when <b>Working Mode</b> is set to <b>VSG</b> . It specifies the voltage deviation corresponding to the rated active power of the virtual synchronous generator.

Parameter	Description
<b>Q-V adjustment coefficient</b>	This parameter is displayed when <b>Working Mode</b> is set to <b>VSG</b> . It specifies the voltage deviation corresponding to the rated reactive power of the virtual synchronous generator.
<b>VSG frequency damping coefficient</b>	This parameter is displayed when <b>Working Mode</b> is set to <b>VSG</b> . It specifies the power factor that prevents the frequency change of the virtual synchronous generator.
<b>VSG excitation time constant</b>	This parameter is displayed when <b>Working Mode</b> is set to <b>VSG</b> . It specifies the time required for the excitation of the virtual synchronous generator to reach the rated voltage.
<b>VSG excitation damping coefficient</b>	This parameter is displayed when <b>Working Mode</b> is set to <b>VSG</b> . It specifies the power factor that prevents the voltage change of the virtual synchronous generator.
<b>VSG output voltage correction coefficient</b>	This parameter is displayed when <b>Working Mode</b> is set to <b>VSG</b> . It corrects the deviation caused by the transformer ratio error.
<b>VSG output frequency correction coefficient</b>	This parameter is displayed when <b>Working Mode</b> is set to <b>VSG</b> . It corrects the inverter output frequency deviation.
<b>Gain for VSG sub-synchronous oscillation damping</b>	This parameter is displayed when <b>Working Mode</b> is set to <b>VSG</b> . It specifies the gain for VSG sub-synchronous oscillation damping.
<b>Frequency band for VSG sub-synchronous oscillation damping</b>	This parameter is displayed when <b>Working Mode</b> is set to <b>VSG</b> . It specifies the frequency band for VSG sub-synchronous oscillation damping.
<b>Per unit armature resistance</b>	This parameter is displayed when <b>Working Mode</b> is set to <b>VSG</b> . It specifies the resistance per unit value for armature windings of the virtual synchronous generator.
<b>Per unit armature inductive reactance</b>	This parameter is displayed when <b>Working Mode</b> is set to <b>VSG</b> . It specifies the inductive reactance per unit value for armature windings of the virtual synchronous generator.
<b>Off-grid VSG inertia time constant</b>	This parameter is displayed when <b>Working Mode</b> is set to <b>VSG</b> . It specifies the time required for the virtual rotor of the virtual synchronous generator to reach the rated speed from the static state under the rated torque.

Table 6-52 VRT

Parameter	Description
<b>Zero-current mode on power grid fault</b>	Specifies whether to set <b>Zero-current mode on power grid fault</b> to <b>Enable</b> .
<b>Grid voltage trip triggering threshold</b>	This parameter is displayed when <b>LVRT</b> or <b>HVRT</b> is set to <b>Enable</b> . If the grid voltage exceeds the value of this parameter, <b>LVRT</b> or <b>HVRT</b> will be triggered.
<b>VRT exit hysteresis threshold</b>	This parameter is displayed when <b>LVRT</b> or <b>HVRT</b> is set to <b>Enable</b> . It specifies the LVRT/HVRT recovery threshold. <ul style="list-style-type: none"> <li>• LVRT recovery threshold = LVRT triggering threshold + VRT exit hysteresis threshold</li> <li>• HVRT recovery threshold = HVRT triggering threshold - VRT exit hysteresis threshold</li> </ul>
<b>VRT active power recovery gradient</b>	This parameter is displayed when <b>LVRT</b> or <b>HVRT</b> is set to <b>Enable</b> . It specifies the gradient for the active current to restore to the value at the moment before fault ride-through.
<b>Deactivate grid voltage protection during VRT</b>	This parameter is displayed when <b>LVRT</b> or <b>HVRT</b> is set to <b>Enable</b> . It specifies whether to set <b>Deactivate grid voltage protection during VRT</b> to <b>Enable</b> .
<b>VRT active current limiting (%)</b>	This parameter is displayed when <b>LVRT</b> or <b>HVRT</b> is set to <b>Enable</b> . It specifies the percentage of the maximum active current to the rated current during fault ride-through.

Table 6-53 HVRT

Parameter	Description
<b>HVRT</b>	HVRT is short for high voltage ride-through. When the grid voltage is abnormally high for a short time, the device shall not disconnect from the power grid immediately and has to work for some time.
<b>HVRT triggering threshold</b>	This parameter is displayed when <b>HVRT</b> is set to <b>Enable</b> . It specifies the threshold for triggering HVRT. The value must comply with the local power grid standard.

Parameter	Description
<b>Positive-sequence reactive power compensation factor in HVRT</b>	<p>This parameter is displayed when <b>HVRT</b> is set to <b>Enable</b>. During HVRT, the inverter needs to generate positive-sequence reactive power to support the power grid. This parameter is used to set the positive-sequence reactive power generated by the inverter.</p> <p>For example, if you set this parameter to <b>2</b>, the increment of positive-sequence reactive current generated by the inverter is 20% of the rated current when the AC voltage increases by 10% during HVRT.</p>
<b>Negative-sequence reactive power compensation factor in HVRT</b>	<p>This parameter is displayed when <b>HVRT</b> is set to <b>Enable</b>. During HVRT, the inverter needs to generate negative-sequence reactive power to support the power grid. This parameter is used to set the negative-sequence reactive power generated by the inverter.</p> <p>For example, if you set this parameter to <b>2</b>, the increment of negative-sequence reactive current generated by the inverter is 20% of the rated current when the AC voltage increases by 10% during HVRT.</p>
<b>HVRT in grid forming mode</b>	<p>This parameter is displayed when <b>HVRT</b> is set to <b>Enable</b>, <b>Working Mode</b> is set to <b>VSG</b>, and <b>Scenario</b> is set to <b>On-grid</b>. It specifies whether to set <b>HVRT in grid forming mode</b> to <b>Enable</b>.</p>
<b>HVRT priority in grid forming mode</b>	<p>This parameter is displayed when <b>HVRT in grid forming mode</b> is set to <b>Enable</b>. It specifies the HVRT priority in grid forming mode.</p>
<b>Voltage regulation type of HVRT in grid forming mode</b>	<p>This parameter is displayed when <b>HVRT in grid forming mode</b> is set to <b>Enable</b>. It specifies the voltage regulation type of HVRT in grid forming mode.</p>
<b>Voltage regulation coefficient of HVRT in grid forming mode</b>	<p>This parameter is displayed when <b>HVRT in grid forming mode</b> is set to <b>Enable</b>. It specifies the voltage regulation coefficient of HVRT in grid forming mode.</p>
<b>Minimum HVRT duration in grid forming mode</b>	<p>This parameter is displayed when <b>HVRT in grid forming mode</b> is set to <b>Enable</b>. It specifies the minimum duration of HVRT.</p>

Table 6-54 LVRT

Parameter	Description
<b>LVRT</b>	LVRT is short for low voltage ride-through. When the grid voltage is abnormally low for a short time, the device shall not disconnect from the power grid immediately and has to work for some time.
<b>LVRT mode</b>	This parameter is displayed when <b>LVRT</b> is set to <b>Enable</b> . It specifies the LVRT mode.
<b>LVRT triggering threshold</b>	This parameter is displayed when <b>LVRT</b> is set to <b>Enable</b> . It specifies the threshold for triggering LVRT. The value must meet the requirements of the local power grid standard.
<b>Threshold of LVRT zero-current mode</b>	This parameter is displayed when <b>LVRT</b> is set to <b>Enable</b> . If <b>Zero-current mode on power grid fault</b> is set to <b>Enable</b> and the grid voltage is lower than the value of this parameter during LVRT, the zero current mode is used. Otherwise, the mode specified by <b>LVRT mode</b> is used.
<b>Positive-sequence reactive power compensation factor in LVRT</b>	This parameter is displayed when <b>LVRT</b> is set to <b>Enable</b> . During LVRT, the inverter needs to generate positive-sequence reactive power to support the power grid. This parameter is used to set the positive-sequence reactive power generated by the inverter.  For example, if you set this parameter to <b>2</b> , the increment of positive-sequence reactive current generated by the inverter is 20% of the rated current when the AC voltage decreases by 10% during LVRT.
<b>Negative-sequence reactive power compensation factor in LVRT</b>	This parameter is displayed when <b>LVRT</b> is set to <b>Enable</b> . During LVRT, the inverter needs to generate negative-sequence reactive power to support the power grid. This parameter is used to set the negative-sequence reactive power generated by the inverter.  For example, if you set this parameter to <b>2</b> , the increment of negative-sequence reactive current generated by the inverter is 20% of the rated current when the AC voltage decreases by 10% during LVRT.
<b>LVRT active current maintenance coefficient</b>	This parameter is displayed when <b>LVRT</b> is set to <b>Enable</b> . It specifies the proportional coefficient of the active current during LVRT to the active current before LVRT.
<b>LVRT reactive current limiting (%)</b>	This parameter is displayed when <b>LVRT</b> is set to <b>Enable</b> . During LVRT, the inverter needs to limit the reactive current.  For example, if this parameter is set to <b>50</b> , the upper limit of the reactive current of the inverter is 50% of the rated current during LVRT.

Parameter	Description
<b>LVRT in grid forming mode</b>	This parameter is displayed when <b>LVRT</b> is set to <b>Enable</b> , <b>Working Mode</b> is set to <b>VSG</b> , and <b>Scenario</b> is set to <b>On-grid</b> . It specifies whether to set <b>LVRT in grid forming mode</b> to <b>Enable</b> .
<b>LVRT priority in grid forming mode</b>	This parameter is displayed when <b>LVRT in grid forming mode</b> is set to <b>Enable</b> . It specifies the LVRT priority in grid forming mode.
<b>Voltage regulation type of LVRT in grid forming mode</b>	This parameter is displayed when <b>LVRT in grid forming mode</b> is set to <b>Enable</b> . It specifies the voltage regulation type of LVRT in grid forming mode.
<b>Voltage regulation coefficient of LVRT in grid forming mode</b>	This parameter is displayed when <b>LVRT in grid forming mode</b> is set to <b>Enable</b> . It specifies the voltage regulation coefficient of LVRT in grid forming mode.
<b>Minimum LVRT duration in grid forming mode</b>	This parameter is displayed when <b>LVRT in grid forming mode</b> is set to <b>Enable</b> . It specifies the minimum duration of LVRT.

Table 6-55 Frequency regulation control

Parameter	Description
<b>Frequency regulation control</b>	Specifies whether to set <b>Frequency regulation control</b> to <b>Enable</b> .
<b>Adjustment ratio for frequency regulation control</b>	This parameter is displayed when <b>Frequency regulation control</b> is set to <b>Enable</b> . According to the standards of certain countries or regions, if the power grid frequency fluctuates around the rated value, the device needs to fine-tune the active power output based on <b>Adjustment ratio for frequency regulation control</b> to help stabilize the grid frequency.
<b>Response deadband for frequency regulation control</b>	This parameter is displayed when <b>Frequency regulation control</b> is set to <b>Enable</b> . It specifies the threshold for triggering frequency regulation. For example, if this parameter is set to 0.1 Hz, frequency regulation is not triggered when the frequency is within reference frequency $\pm$ 0.1 Hz.
<b>Power change gradient for frequency regulation control</b>	This parameter is displayed when <b>Frequency regulation control</b> is set to <b>Enable</b> . It specifies the power change gradient for frequency regulation control.

Parameter	Description
<b>Power change limit for frequency regulation control</b>	This parameter is displayed when <b>Frequency regulation control</b> is set to <b>Enable</b> . It specifies the power change limit for frequency regulation control.
<b>Delay of frequency regulation control</b>	This parameter is displayed when <b>Frequency regulation control</b> is set to <b>Enable</b> . It specifies the delay of frequency regulation control.
<b>Upper power change limit of frequency-based control</b>	This parameter is displayed when <b>Frequency regulation control</b> is set to <b>Enable</b> . It specifies the upper power change limit for frequency regulation control.
<b>Lower power change limit of frequency-based control</b>	This parameter is displayed when <b>Frequency regulation control</b> is set to <b>Enable</b> . It specifies the lower power change limit for frequency regulation control.
<b>Frequency detection filter time</b>	This parameter is displayed when <b>Frequency regulation control</b> , <b>Underfrequency-caused power raising</b> , or <b>Overfrequency-caused power derating</b> is set to <b>Enable</b> . It specifies the frequency detection filter time.
<b>Hysteresis of frequency-based active power derating</b>	This parameter is displayed when <b>Frequency regulation control</b> , <b>Underfrequency-caused power raising</b> , or <b>Overfrequency-caused power derating</b> is set to <b>Enable</b> . It specifies whether to set <b>Hysteresis of frequency-based active power derating</b> to <b>Enable</b> .
<b>Recovery delay of frequency-based active power derating</b>	This parameter is displayed when <b>Frequency regulation control</b> , <b>Underfrequency-caused power raising</b> , or <b>Overfrequency-caused power derating</b> is set to <b>Enable</b> . It specifies the delay time for exiting overfrequency-caused power derating after the frequency reaches the specified threshold. It specifies the recovery delay of frequency-based active power derating.
<b>Execution delay of frequency-based active power derating</b>	This parameter is displayed when <b>Frequency regulation control</b> , <b>Underfrequency-caused power raising</b> , or <b>Overfrequency-caused power derating</b> is set to <b>Enable</b> . It specifies the execution delay of frequency-based active power derating.

Table 6-56 Overfrequency-caused power derating

Parameter	Description
<b>Overfrequency-caused power derating</b>	Specifies whether to set <b>Overfrequency-caused power derating</b> to <b>Enable</b> .

Parameter	Description
<b>Frequency threshold for triggering overfrequency-caused power derating</b>	This parameter is displayed when <b>Overfrequency-caused power derating</b> is set to <b>Enable</b> . When the power grid frequency exceeds the <b>Frequency threshold for triggering overfrequency-caused power derating</b> , the active power of the device is derated based on a certain gradient. When setting this parameter, ensure that the following condition is met: <b>Frequency threshold for exiting overfrequency-caused power derating</b> $\leq$ <b>Frequency threshold for triggering overfrequency-caused power derating</b> $<$ <b>Frequency threshold for stopping overfrequency-caused power derating</b> .
<b>Frequency threshold for exiting overfrequency-caused power derating</b>	This parameter is displayed when <b>Overfrequency-caused power derating</b> is set to <b>Enable</b> . When setting this parameter, ensure that the following condition is met: <b>Frequency threshold for exiting overfrequency-caused power derating</b> $\leq$ <b>Frequency threshold for triggering overfrequency-caused power derating</b> $<$ <b>Frequency threshold for stopping overfrequency-caused power derating</b> .
<b>Frequency threshold for stopping overfrequency-caused power derating</b>	This parameter is displayed when <b>Overfrequency-caused power derating</b> is set to <b>Enable</b> . When setting this parameter, ensure that the following condition is met: <b>Frequency threshold for exiting overfrequency-caused power derating</b> $\leq$ <b>Frequency threshold for triggering overfrequency-caused power derating</b> $<$ <b>Frequency threshold for stopping overfrequency-caused power derating</b> .
<b>Gradient of power recovery from overfrequency-caused derating</b>	This parameter is displayed when <b>Overfrequency-caused power derating</b> is set to <b>Enable</b> . It specifies the gradient of power recovery from overfrequency-caused derating.
<b>Gradient of overfrequency-caused power derating</b>	This parameter is displayed when <b>Overfrequency-caused power derating</b> is set to <b>Enable</b> . It specifies the gradient of overfrequency-caused power derating.
<b>PCS power threshold for stopping overfrequency-caused power derating</b>	This parameter is displayed when <b>Overfrequency-caused power derating</b> is set to <b>Enable</b> . It specifies the power threshold for stopping overfrequency-caused power derating.

Table 6-57 Underfrequency-caused power raising

Parameter	Description
<b>Underfrequency-caused power raising</b>	Specifies whether to set <b>Underfrequency-caused power raising</b> to <b>Enable</b> .
<b>Frequency threshold for triggering underfrequency-caused power raising</b>	This parameter is displayed when <b>Underfrequency-caused power raising</b> is set to <b>Enable</b> . The standards of certain countries and regions require that if the power grid frequency is lower than <b>Frequency threshold for triggering underfrequency-caused power raising</b> , the device needs to increase the active power output to raise the power grid frequency.
<b>Frequency threshold for exiting underfrequency-caused power raising</b>	This parameter is displayed when <b>Underfrequency-caused power raising</b> is set to <b>Enable</b> . It specifies the frequency threshold for exiting underfrequency-caused power raising.
<b>Frequency threshold for stopping underfrequency-caused power raising</b>	This parameter is displayed when <b>Underfrequency-caused power raising</b> is set to <b>Enable</b> . It specifies the frequency threshold for stopping underfrequency-caused power raising.
<b>Gradient of underfrequency-caused power raising</b>	This parameter is displayed when <b>Underfrequency-caused power raising</b> is set to <b>Enable</b> . It specifies the gradient of underfrequency-caused power raising.
<b>Delay of underfrequency-caused power raising</b>	This parameter is displayed when <b>Underfrequency-caused power raising</b> is set to <b>Enable</b> . It specifies the delay of underfrequency-caused power raising.
<b>PCS power threshold for stopping underfrequency-caused power raising</b>	This parameter is displayed when <b>Underfrequency-caused power raising</b> is set to <b>Enable</b> . It specifies the PCS power threshold for stopping underfrequency-caused power raising.

Table 6-58 Power adjustment

Parameter	Description
<b>Remote power scheduling</b>	Specifies whether to set <b>Remote power scheduling</b> to <b>Enable</b> . If this parameter is set to <b>Enable</b> , the inverter responds to the scheduling command from the remote port. If this parameter is set to <b>Disable</b> , the inverter does not respond to the scheduling command from the remote port.
<b>Power Factor</b>	This parameter is displayed when <b>Remote power scheduling</b> is set to <b>Enable</b> . It specifies the power factor of the inverter.
<b>Reactive power change gradient</b>	This parameter is displayed when <b>Remote power scheduling</b> is set to <b>Enable</b> . It specifies the reactive power change gradient.
<b>Active power change gradient</b>	This parameter is displayed when <b>Remote power scheduling</b> is set to <b>Enable</b> . It specifies the active power change gradient.
<b>Active power (kW)</b>	This parameter is displayed when <b>Remote power scheduling</b> is set to <b>Enable</b> . It specifies the active power (kW).
<b>Active power (%) [high precision]</b>	This parameter is displayed when <b>Remote power scheduling</b> is set to <b>Enable</b> . It specifies the active power (%).
<b>Reactive power compensation (Q/S) [high precision]</b>	This parameter is displayed when <b>Remote power scheduling</b> is set to <b>Enable</b> . It specifies the reactive power output by the inverter.
<b>Power control priority</b>	<ul style="list-style-type: none"><li>● <b>Active power first</b>: The device preferentially ensures the active output.</li><li>● <b>Reactive power first</b>: The device preferentially ensures the reactive output.</li></ul>
<b>Schedule instruction valid duration</b>	Specifies the validity period of the scheduling instruction. If this parameter is set to <b>0</b> , the scheduling instruction is effective permanently.
<b>Plant active power gradient</b>	Specifies the rate of active power rise due to irradiance changes.
<b>Filtering time of the average active power of the plant</b>	Specifies the period of active power rise due to irradiance changes.

**Table 6-59** Power baseline

Parameter	Description
<b>apparent power reference</b>	Specifies the apparent power baseline for power scheduling. The value cannot be greater than <b>Maximum apparent power</b> .
<b>Active power reference</b>	Specifies the active power baseline for power scheduling. The value cannot be greater than <b>Maximum active power</b> .
<b>Maximum apparent power</b>	Specifies the output upper threshold for the maximum apparent power to adapt to the capacity requirements of standard and customized inverters.
<b>Maximum active power</b>	Specifies the output upper threshold for the maximum active power to adapt to different market requirements.

**Table 6-60** Protection upon communication failure

Parameter	Description
<b>Shutdown upon communication failure</b>	Specifies whether to set <b>Shutdown upon communication failure</b> to <b>Enable</b> . The device will shut down when communication has been interrupted beyond the duration specified by <b>Shutdown duration during communication failure</b> .
<b>Startup upon communication recovery</b>	This parameter is displayed when <b>Shutdown upon communication failure</b> is set to <b>Enable</b> . It specifies whether to set <b>Startup upon communication recovery</b> to <b>Enable</b> . If this parameter is set to <b>Enable</b> , the device automatically starts after the communication recovers.
<b>Shutdown duration during communication failure</b>	The device will shut down when communication has been interrupted beyond the duration specified by <b>Shutdown duration during communication failure</b> .
<b>Protection upon Communication Failure</b>	Specifies whether to set <b>Protection upon Communication Failure</b> to <b>Enable</b> . If this parameter is set to <b>Enable</b> , the device performs protection based on the preset power when it fails to communicate with the SmartMGC.
<b>Communication disconnection duration</b>	This parameter is displayed when <b>Protection upon Communication Failure</b> is set to <b>Enable</b> . If communication between the inverter and the SmartMGC is interrupted beyond the duration specified by this parameter, it is considered as a failure.

Parameter	Description
<b>Failure protection active power mode</b>	This parameter is displayed when <b>Protection upon Communication Failure</b> is set to <b>Enable</b> . It specifies the active power mode adopted when communication fails.
<b>Active power limit (kW) when communication fails [high precision]</b>	This parameter is displayed when <b>Failure protection active power mode</b> is set to <b>Fixed value</b> . It specifies the active power limit when communication fails.
<b>Active power limit (%) when communication fails [high precision]</b>	This parameter is displayed when <b>Failure protection active power mode</b> is set to <b>Percentage</b> . It specifies the active power limit when communication fails.
<b>Failure protection reactive power mode</b>	This parameter is displayed when <b>Protection upon Communication Failure</b> is set to <b>Enable</b> . It specifies the reactive power mode adopted when communication fails.
<b>Reactive power limit (PF) when communication fails</b>	This parameter is displayed when <b>Failure protection reactive power mode</b> is set to <b>Power Factor</b> . It specifies the reactive power limit when communication fails.
<b>Reactive power limit (Q/S) when communication fails [high precision]</b>	This parameter is displayed when <b>Failure protection reactive power mode</b> is set to <b>Q/S</b> . It specifies the reactive power limit when communication fails.

Table 6-61 Energy adjustment

Parameter	Description
<b>Adjusted total energy yield</b>	A calibrating coefficient for the total energy yield to ensure that the reported energy yield is consistent with the actual energy yield at the grid-connection point
<b>Adjusted total power supply from grid</b>	A calibrating coefficient for the total power supply from the grid to ensure that the reported amount of power supplied from the grid is consistent with the actual power supply at the grid connection point
<b>Clear historical yield</b>	Clears historical yield records.

Table 6-62 O&amp;M parameters

Parameter	Description
<b>Upgrade rollback prevention</b>	Specifies whether to set <b>Upgrade rollback prevention</b> to <b>Enable</b> . If this parameter is set to <b>Enable</b> , the version cannot be rolled back during a software upgrade.
<b>Display module brightness</b>	Specifies the display module brightness.
<b>[WLAN] Wakeup</b>	Wakes up the WLAN.
<b>Location of pack <math>\alpha</math><sup>[1]</sup></b>	Specifies the location ID of a battery pack.
[1]: $\alpha = 1-4$	

Table 6-63 Startup authorization

Parameter	Description
<b>Startup authorization code</b>	Set <b>Startup authorization code</b> . Otherwise, the ESS cannot be started. Contact the ESS supplier or installer to obtain the startup authorization code.

Table 6-64 RCD configuration

Parameter	Description
<b>Current threshold for triggering RCD protection</b>	An RCD is an electrical safety device that detects leakage current in a circuit and quickly cuts off the circuit when an exception is detected. If this parameter is set to a small value, the device may frequently trigger the protection mechanism. Set this parameter with caution. If you have any question, contact technical support.

## Characteristic Curve

If the remote reactive power control command is unavailable, the SmartMGC provides the characteristic curve configuration function as a substitute. After the SmartMGC delivers the characteristic curve configuration to the device, the device executes the configuration, and the SmartMGC does not implement adjustment.

### NOTE

Path: **Monitoring > ESS > Characteristic Curve**

- **Q-U characteristic curve**

In the Q-U characteristic curve control mode, the device dynamically adjusts the ratio  $Q/S$  of output reactive power to apparent power in accordance with the ratio  $U/U_n$  of the actual grid voltage to the rated grid voltage.

**Table 6-65** Q-U characteristic curve

Parameter	Description
Q-U characteristic curve mode	Specifies the Q-U characteristic curve mode.
Reactive power adjustment time	Specifies the change interval of the reactive power at the grid connection point.
Q-U scheduling triggering power percentage	Under a specific grid code, the characteristic curve takes effect only when the actual output active power of the device is greater than the specified value.
Q-U Scheduling Exit Power Percentage	Under a specific grid code, the characteristic curve becomes invalid only when the actual output active power of the device is less than the specified value.
Q-U characteristic curve minimum PF limit	Limits the actual minimum PF when the Q-U characteristic curve takes effect.
Q-U curve delay time	Specifies the delay time for the Q-U characteristic curve to take effect.
Q-U characteristic curve setting	Set this parameter as required. When configuring the curve, ensure that the $U/U_n$ value of a point is greater than the $U/U_n$ value of the previous point.
U/ $U_n$	
Q/S	

- **$\cos\phi$ -P/ $P_n$  characteristic curve**

In the  $\cos\phi$ -P/ $P_n$  characteristic curve control mode, the device dynamically adjusts the power factor  $\cos\phi$  in accordance with the  $P/P_n$  based on the VDE-4105 and BDEW German standards.

**Table 6-66**  $\cos\phi$ -P/ $P_n$  characteristic curve

Parameter	Description
Reactive power adjustment time	Time for the reactive power to reach the target value.
$\cos\phi$ -P/ $P_n$ trigger voltage	Specifies the voltage for triggering the $\cos\phi$ -P/ $P_n$ characteristic curve.

Parameter	Description
<b>cosφ-P/Pn exit voltage</b>	Specifies the voltage for exiting the cosφ-P/Pn characteristic curve.
<b>cosφ-P/Pn characteristic curve setting</b>	Set this parameter as required. When configuring the curve, ensure that the <b>P/Pn</b> value of a point is greater than the <b>P/Pn</b> value of the previous point.
<b>P/Pn</b>	
<b>cosφ</b>	

- **PF-U characteristic curve**

In the PF-U characteristic curve control mode, the device dynamically adjusts the **U/Un** at the device port based on the ratio **U/Un** of the actual grid voltage to the rated grid voltage.

**Table 6-67** PF-U characteristic curve

Parameter	Description
<b>PF-U characteristic curve setting</b>	Set this parameter as required. When configuring the curve, ensure that the <b>U/Un</b> value of a point is greater than the <b>U/Un</b> value of the previous point.
<b>U/Un</b>	
<b>French Polynesia</b>	

- **Q-P characteristic curve**

In the Q-P characteristic curve control mode, the device adjusts the ratio **Q/Pn** of the output reactive power to the rated power based on the ratio **P/Pn** of the current active power to the rated power.

**Table 6-68** Q-P characteristic curve

Parameter	Description
<b>Reactive power adjustment time</b>	Time for the reactive power to reach the target value.
<b>Q-P characteristic curve setting</b>	Set this parameter as required. When configuring the curve, ensure that the <b>P/Pn</b> value of a point is greater than the <b>P/Pn</b> value of the previous point.
<b>P/Pn</b>	
<b>Q/Pn</b>	

- **LVRT characteristic curve**

**Table 6-69** LVRT characteristic curve

Parameter	Description
<b>LVRT Characteristic Curve</b>	Set these parameters as required. When configuring the curve, ensure that the <b>t</b> value of a point is greater than the <b>t</b> value of the previous point.
<b>t</b>	
<b>U/Uc</b>	

- **HVRT characteristic curve**

**Table 6-70** HVRT characteristic curve

Parameter	Description
<b>HVRT Characteristic Curve</b>	Set these parameters as required. When configuring the curve, ensure that the <b>t</b> value of a point is greater than the <b>t</b> value of the previous point.
<b>t</b>	
<b>U/Uc</b>	

## Performance Data

On the performance data page, you can click **Export** to export device performance data.

## 6.4.4 MBUS

### 6.4.4.1 MBUS-Inside

#### Running parameters

 **NOTE**

Path: **Monitoring > MBUS-Inside > Running Parameters**

**Table 6-71** Parameter settings

Parameter	Description
<b>Power setting</b>	This parameter is used to adjust the transmit power of MBUS signals. A larger value indicates a higher transmit power and better networking capability. Set this parameter as required.

Parameter	Description
<b>Network frequency band</b>	Retain the default value. Modifying the network frequency band will trigger re-networking. Wait for 5 minutes and then perform MBUS-related operations. If you have any questions, contact the supplier or technical support.
<b>SN ID</b>	Specifies the SN ID of the device. It is used to identify the SN ID of the device for communication with the inverter through the MBUS protocol. In normal cases, the system automatically resolves conflicts caused by duplicate SN IDs. There is no need to change the SN ID unless otherwise specified.

**Table 6-72** Function settings

Parameter	Description
<b>Anti-crosstalk</b>	Specifies whether to set <b>Anti-crosstalk</b> to <b>Enable</b> . If this parameter is set to <b>Enable</b> and the inverter SN is in the <b>SN List</b> , the inverter can connect to the SmartMGC through MBUS networking.
<b>Networking</b>	<ul style="list-style-type: none"><li>• <b>Enable</b>: Set this parameter to <b>Enable</b> when the SmartMGC communicates with the inverter through MBUS.</li><li>• <b>Disable</b>: Set this parameter to <b>Disable</b> when the SmartMGC communicates with the inverter through RS485.</li></ul>
<b>Fast scheduling</b>	Specifies whether to set <b>Fast scheduling</b> to <b>Enable</b> .
<b>Reset</b>	Set this parameter as required.
<b>Maintenance and test record</b>	Specifies whether to enable maintenance and test recording.
<b>PLC packet record duration</b>	PLC packets are recorded based on the configured duration. If the value is <b>10 min</b> , PLC packets within 10 minutes are recorded.

## SN List

### NOTE

Path: **Monitoring** > **MBUS-Inside** > **SN List**

**Table 6-73** SN list

Parameter	Description
<b>SN</b>	<ul style="list-style-type: none"> <li>• Enter the inverter SN. If MBUS networking is used, an SN list, that is, a whitelist, must be set for inverters.</li> <li>• Set the inverter whitelist as follows:                             <ul style="list-style-type: none"> <li>- One by one: Click <b>Add</b>, enter the SN of the corresponding inverter, and click <b>Submit</b>.</li> <li>- In batches:                                     <p>Method 1: If this is the first time to configure the whitelist, click <b>Download Template</b> to download the template to the local PC, enter the inverter SNs in the template, and click <b>Import</b> to import the modified template.</p> <p>Method 2: If this is not the first time to configure the whitelist, click <b>Export</b> to download the template to the local PC, add the inverter SNs to the template based on the template format, and click <b>Import</b> to import the modified template.</p> <p><b>NOTE</b> Rules for completing the template:</p> <ul style="list-style-type: none"> <li>• SN column: Enter an SN in each cell in the <b>SN:XXXXXX</b> format.</li> <li>• Location No. column: This column is optional.</li> </ul> </li> </ul> </li> </ul>
<b>Match Status</b>	Display the inverter matching status and device information.
<b>Device Name</b>	
<b>Communications Address</b>	

## 6.4.5 METER

### 6.4.5.1 Modbus Meter

#### Running Parameters

 **NOTE**

Path: **Monitoring > METER > Running Parameters**

**Table 6-74** Basic parameters

Parameter	Description
<b>Meter usage</b>	<ul style="list-style-type: none"> <li>• <b>Feed-in meter:</b> used for grid-connection point control. Each array allows only one feed-in meter to be connected.</li> <li>• <b>Production meter:</b> PV output meter. Multiple production meters can be connected.</li> <li>• <b>Consumption meter:</b> load consumption meter. Multiple consumption meters can be connected.</li> <li>• <b>Charger meter:</b> charger consumption meter. Multiple charger meters can be connected.</li> <li>• <b>Third-party production meter:</b> third-party PV output meter. Multiple third-party production meters can be connected.</li> </ul>
<b>Meter access direction</b>	<p>If the meter cable is connected in the reverse direction, you can adjust the settings on the software without correcting the cable connection.</p> <ul style="list-style-type: none"> <li>• <b>Positive:</b> The meter is connected in the correct direction.</li> <li>• <b>Reverse:</b> The meter is connected in the reverse direction, and the management system does not support reverse meter connection.</li> <li>• <b>Reverse_Report raw data:</b> This option is valid only for <b>Feed-in meter</b>. The meter is connected in the reverse direction, and the management system supports reverse meter connection<sup>[1]</sup>. The SmartMGC reports the original meter data to the management system, which adjusts the meter data such as power.</li> </ul>
<b>Voltage ratio</b>	<ul style="list-style-type: none"> <li>• Set this parameter to <b>1</b> if the meter uploads the primary value.</li> <li>• Set this parameter based on the actual transformer ratio if the meter uploads the secondary value.</li> <li>• If both the meter and the SmartMGC support the settings of the voltage ratio and current ratio, you can only set them either on the meter or the SmartMGC. You are advised to set these parameters on the meter.</li> </ul>
<b>Current ratio</b>	
<p>[1]: If the meter is connected in the reverse direction and the management system can correctly display the real-time data of the meter, the management system supports reverse meter connection.</p>	

## Performance Data

On the performance data page, you can click **Export** to export device performance data.

## 6.4.6 EMI

### Running Parameters

 NOTE

Path: **Monitoring > EMI > Running Parameters**

**Table 6-75** Basic parameters

Parameter	Description
<b>Master-slave mode</b>	<p>If multiple EMIs are connected to the SmartMGC, you can set one of them to <b>Master mode</b>. The data of the EMI working in <b>Master mode</b> is displayed on the inverter performance data page.</p> <p><b>NOTE</b></p> <ul style="list-style-type: none"><li>• No matter whether an EMI is set to <b>Master mode</b> or <b>Slave mode</b>, the EMI data is displayed on both the inverter performance data and plant performance data pages.</li><li>• If multiple EMIs are connected to the SmartMGC, only one EMI can be set to <b>Master mode</b>. If multiple EMIs are set to <b>Master mode</b>, only the last configuration takes effect, that is, the last EMI works in <b>Master mode</b> and the other EMIs are automatically switched to <b>Slave mode</b>.</li><li>• If multiple EMIs are connected to the SmartMGC and these EMIs are set to <b>Slave mode</b>, the performance data of the first connected EMI is displayed on both the inverter performance data and plant performance data pages.</li></ul>
<b>Synchronize environment data</b>	<ul style="list-style-type: none"><li>• <b>Disable</b>: Environment data is not synchronized. You are advised to retain the default value <b>Disable</b>.</li><li>• <b>Enable</b>: The SmartMGC sends the wind speed and wind direction data to inverters.</li></ul>
<b>Wind speed threshold for fast synchronization</b>	<ul style="list-style-type: none"><li>• When the actual wind speeds collected by all running EMIs are within the wind speed threshold for fast synchronization, all EMIs synchronize the real-time wind speeds to inverters every minute by default. The inverters forward the real-time wind speeds to trackers.</li><li>• When the actual wind speed collected by any running EMI exceeds the threshold, all running EMIs will send the real-time wind speeds five times at an interval of 10s. After that, the real-time wind speeds are synchronized to the inverters every minute.</li></ul>

## 6.5 Query

### Historical Alarms

On the historical alarms page, you can view the historical alarms and filter alarms by **Device** and **Time**.

#### NOTE

Path: **Query > Historical Alarms**

**Figure 6-9** Historical alarms

Device:  Time:  -  Sort by:

Device	Alarm ID	Severity	Alarm Name	Generated At	End Time	Cause ID
Logger	1154	Minor	-	2025-07-25 14:48:31	2025-07-25 16:16:15	1
Logger	1154	Minor	-	2025-07-25 14:17:12	2025-07-25 14:45:06	1
Logger	1154	Minor	-	2025-07-24 22:53:18	2025-07-24 23:05:30	1
Logger	1154	Minor	-	2025-07-24 19:49:55	2025-07-24 21:36:38	3
Logger	1154	Minor	-	2025-07-24 10:02:39	2025-07-24 15:57:05	1
Logger	1154	Minor	-	2025-07-23 13:52:59	2025-07-23 13:57:30	1
Logger	1154	Minor	-	2025-07-23 13:34:06	2025-07-23 13:44:05	1
Logger	1154	Minor	-	2025-07-23 13:04:17	2025-07-23 13:06:23	1
Logger	1154	Minor	-	2025-07-23 09:58:29	2025-07-23 10:02:17	1

### Operation Logs

On the operation logs page, you can view the historical operation information and filter the information by **Operation source** and **Username**.

#### NOTE

Path: **Query > Operation Log**

**Figure 6-10** Operation logs

Operation source:  Username:

No.	Username	Operation source	Parameter	Operation Time
1	mfq	WEB	Login IP: 192.168.0.11	2025-07-25 17:56:51
2	mfq	WEB	Login IP: 192.168.0.11	2025-07-25 15:15:07
3	mfq	WEB	Login IP: 192.168.0.11	2025-07-25 14:31:19
4	mfq	WEB	Login IP: 192.168.8.11	2025-07-24 15:36:00
5	mfq	WEB	Logout: due to timeout	2025-07-23 10:27:48
6	mfq	WEB	Login IP: 192.168.8.11	2025-07-23 10:07:39
7	mfq	WEB	Logout: due to user login	2025-07-23 10:07:39
8	mfq	WEB	Login IP: 192.168.8.11	2025-07-23 10:07:39

### Security Events

On the **Security Events** page, you can view historical security events.

#### NOTE

Path: **Query > Security Events**

**Figure 6-11** Security events

No.	Event Type	Severity	Generated At	Event Description
1	Key file tampering	Major	2025-07-22 11:26:38	The file has been modify, path=/mnt/kp/etc/ssh_config
2	Key file tampering	Major	2025-07-22 11:24:53	The file has been modify, path=/mnt/kp/etc/ssh_config
3	Key file tampering	Major	2025-07-18 13:36:13	The file has been delete, path=/mnt/bsp/extend_roots/bin/login
4	Key file tampering	Major	2025-07-18 13:36:13	The file has been delete, path=/mnt/bsp/extend_roots/usr/bin/passwd
5	Key file tampering	Major	2025-07-18 10:14:31	The file has been modify, path=/mnt/bsp/extend_roots/bin/login
6	Key file tampering	Major	2025-07-18 10:14:31	The file has been attribute, path=/mnt/bsp/extend_roots/bin/login
7	Key file tampering	Major	2025-07-18 10:14:31	The file has been modify, path=/mnt/bsp/extend_roots/usr/bin/passwd
8	Key file tampering	Major	2025-07-18 10:14:31	The file has been attribute, path=/mnt/bsp/extend_roots/usr/bin/passwd
9	Key file tampering	Major	2025-07-17 06:55:14	The file has been modify, path=/mnt/bsp/extend_roots/bin/login

## Security Logs

On the **Security Logs** page, you can view historical security logs.

### NOTE

Path: **Query > Security Logs**

**Figure 6-12** Security logs

No.	Username	Operation Time	Operation Source	Severity	Operation Details
1	mfq	2025-07-25 17:56:51	WEB	Major	Login IP: 192.168.0.11
2	installer	2025-07-25 17:37:13	WEB	Major	Login IP: 192.168.0.11
3	installer	2025-07-25 17:26:54	APP	Major	User login
4	installer	2025-07-25 17:19:06	WEB	Major	Login IP: 192.168.0.11
5	installer	2025-07-25 17:16:35	WEB	Major	Recertification: successful
6	installer	2025-07-25 17:15:19	WEB	Major	Login IP: 192.168.0.11
7	installer	2025-07-25 17:15:08	APP	Major	User login
8	installer	2025-07-25 17:14:59	WEB	Major	Login IP: 192.168.0.11
9	installer	2025-07-25 17:13:38	APP	Major	User login
10	installer	2025-07-25 17:13:21	WEB	Major	Login IP: 192.168.0.11

## Data Export

On the **Data Export** page, you can export historical data that matches the specified data type and period.

### NOTE

Path: **Query > Data Export**

**Figure 6-13** Data export

The screenshot shows a web interface for data export. It contains three main input areas:
 

- A dropdown menu labeled '\* Data type' with 'All' selected.
- A dropdown menu labeled '\* Period' with 'All' selected.
- An input field labeled 'Export encryption password' with a help icon and a placeholder text: 'If you need to encrypt the data to be exported, enter the e...'. There is also a small circular icon with a question mark to the right of the input field.
- A blue 'Submit' button located below the input fields.

**Step 1** Click the **Data type** filter box and select a data type.

**Step 2** Click the **Period** filter box and select a time period.

**Step 3** (Optional) Enter **Export encryption password**.

**Step 4** Click **Submit** to export data.

----End

## 6.6 Settings

### 6.6.1 Date and Time

**NOTE**

Path: **Set > Date and Time**

**Table 6-76** Date and time

Parameter	Description
<b>Time zone</b>	Specifies the local time zone.
<b>DST</b>	This parameter is displayed when <b>Time zone</b> is set to a specific time zone. It specifies whether to set <b>DST</b> to <b>Enable</b> . If this parameter is set to <b>Enable</b> , time in DST is one hour faster than that in GMT. The setting enables that solar irradiance can be sufficiently harnessed.
<b>Date and Time</b>	Specifies the local date and time.
<b>Clock source</b> <sup>[1]</sup>	Specifies the clock source. If this parameter is set to <b>NTP</b> , you can click <b>NTP Synchronization Test</b> to perform a test. <b>NOTE</b> Clock source precision specifications: <ul style="list-style-type: none"> <li>• NTP/IEC 104/Modbus TCP: 1s</li> <li>• Management system/MPTP: 1 ms</li> </ul>

Parameter	Description
Server	These parameters are displayed when <b>Clock source</b> is set to <b>NTP</b> . They specify the information about the time synchronization server and the synchronization interval.
Server2	
Port	
Synchronization time interval	
Time synchronization server	Display time synchronization information.
Latest synchronization time	
[1]: If no management system is available, you do not need to set the parameter.	

#### NOTICE

- Changing the time zone and system time will affect the system energy yield and the integrity of performance data records. Do not change the time zone or system time unless necessary.
- After the date and time are set, the time of all inverters connected to the SmartMGC will be synchronized to that time. Ensure that the settings are correct.

## 6.6.2 Port Settings

### 6.6.2.1 WLAN

#### NOTE

Path: **Set > Port Settings > WLAN**

Table 6-77 WLAN

Parameter	Description
O&M policy	<ul style="list-style-type: none"><li>• <b>Always ON:</b> The WLAN module is powered on.</li><li>• <b>OFF when idle:</b> The WLAN module is automatically powered off when it is idle. You can press and hold the RST button for 1s to 3s to power on the WLAN module. Then, the COM indicator is steady on for 2 minutes (it will restore to the original state 2 minutes later), and the module is waiting for connecting to an app. If not connected to the app, the WLAN module is automatically powered off 4 hours after being powered on.</li><li>• <b>Always OFF:</b> The WLAN module is not powered on.</li></ul>
SSID	Specifies the WLAN name. The initial WLAN name is <i>Logger_SN</i> . You can view the SN on the device.
Password	Specifies the WLAN access password. You can obtain the initial WLAN password from the device label, that is, the characters following <b>PSW</b> .

**NOTICE**

You are advised to periodically update the WLAN password. A password that has been used for a long time is more likely to be stolen or cracked.

## App Access

The app communicates with the SmartMGC through WLAN for users to query alarms, set parameters, and perform routine maintenance.

**NOTE**

App access prerequisites:

- The WLAN function is enabled.
- The FusionSolar app or SUN2000 app has been installed on the mobile phone (Android 8.0 or iOS 18.0 or later).
- **FusionSolar app** (SmartMGC connected to the FusionSolar SmartPVMS)
  - a. Open the FusionSolar app and log in as an installer.
  - b. Choose **Services > Device Commissioning** to access the WLAN connection screen. (If the Internet access is unavailable, skip step 1 and directly tap **:: > Commission Device** in the upper right corner of the app login screen to access the WLAN connection screen.)
  - c. Connect to the WLAN of the SmartMGC to access the login screen.
  - d. Enter the account name and password. (The default account is **installer**. Set the password upon the first login.)

- e. Tap **Log In**.
- **SUN2000 app** (SmartMGC connected to another management system)
  - a. Open the SUN2000 app and connect to the WLAN hotspot of the SmartMGC to access the login screen.
  - b. Enter the account name and password. (The default account is **installer**. Set the password upon the first login.)
  - c. Tap **Log In**.

 **NOTE**

- The initial name of the WLAN of the SmartMGC is **Logger\_SM**. You can find the SN on the device.
- For the first connection to the WLAN, log in with the initial password. You can find the initial password of the WLAN on the device label, that is, the characters following **PSW**. Change the password as soon as possible. You are advised to change the password periodically. After changing the password, remember the new password to ensure account security. Your password might be stolen or cracked if it is left unchanged for an extended period. If a password is lost, the device cannot be accessed.
- If the SmartMGC is powered on for the first time or restored to factory settings and no parameter is set on the WebUI, the quick settings screen is displayed when you log in to the app as **installer**. You can set parameters as required.

### 6.6.2.2 Mobile Network

 **NOTE**

- Path: **Set > Port Settings > Mobile Network**
- This page displays only 4G communication parameters for the SmartMGC.

**Table 6-78** Mobile network

Parameter	Description
<b>Monthly data plan</b>	Specifies the monthly data plan of the SIM card.
<b>Network mode</b>	Set this parameter based on the SIM card network mode.
<b>APN mode</b>	The default value is <b>Automatic</b> . Set this parameter to <b>Manual</b> if the dial-up connection cannot be set up in <b>Automatic</b> mode.
<b>User APN authentication type</b>	This parameter is displayed when APN mode is set to <b>Manual</b> . It specifies the type of user identity authentication. <ul style="list-style-type: none"> <li>• <b>PAP</b>: Password Authentication Protocol</li> <li>• <b>CHAP</b>: Challenge Handshake Authentication Protocol</li> </ul>
<b>APN</b>	This parameter is displayed when <b>APN mode</b> is set to <b>Manual</b> . If this parameter is incorrectly set, the mobile network services will be affected. The parameter information comes from the SIM card carrier. If you have any questions about the parameter settings, contact Huawei engineers.
<b>Dialup number</b>	
<b>Username</b>	
<b>Password</b>	

**NOTICE**

Data that is proactively sent through email or FTP is preferentially transmitted through 4G wireless communication. If the email or FTP function is used, ensure that the 4G wireless network is connected to the corresponding target server.

**6.6.2.3 Ethernet** **NOTE**

Path: **Set > Port Settings > Ethernet**

**Table 6-79** Network configuration

Parameter	Description
<b>ESS ring network</b>	Specifies the ring network port. The default value is <b>GE3+GE4</b> . Select the ring network type based on the site requirements and then perform related commissioning. <ul style="list-style-type: none"> <li>• <b>GE3+GE4</b>: used in scenarios where the communication distance is equal to or less than 100 m (ESSs are deployed in a centralized manner).</li> <li>• <b>SFP1+SFP2</b>: used in scenarios where the communication distance is greater than 100 m (ESSs are deployed in a decentralized manner).</li> </ul>
<b>WAN port DHCP</b>	Specifies whether to set <b>WAN port DHCP</b> to <b>Enable</b> . This parameter can be set only on the app.

**Table 6-80** Ethernet

Parameter	Description
<b>Port</b>	Specifies the network port.
<b>Function</b>	<ul style="list-style-type: none"> <li>• <b>Southbound</b>: Connects to a device such as ESS.</li> <li>• <b>Northbound</b>: Connects to the FusionSolar SmartPVMS or a management system.</li> </ul>
<b>IP address</b>	Retain the default value or change it as required. The network ports are independent of each other and their configurations cannot conflict with each other.
<b>Subnet Mask</b>	
<b>Default Gateway</b>	
<b>DNS1</b> <sup>[1]</sup>	<ul style="list-style-type: none"> <li>• You can ignore this parameter if the device connects to the LAN.</li> <li>• Set this parameter to the IP address of the LAN router when the device connects to the public network (for example, connecting to the FusionSolar SmartPVMS, email server, or third-party FTP server).</li> </ul>

Parameter	Description
DNS2 <sup>[1]</sup>	<ul style="list-style-type: none"> <li>This parameter does not need to be set in normal cases.</li> <li>If the primary DNS server cannot resolve the domain name, use the secondary DNS server.</li> </ul>
[1]: DNS servers can be set only for WAN ports.	

### 6.6.2.4 RS485

 NOTE

Path: **Set > Port Settings > RS485**

Table 6-81 RS485

Parameter	Description
<b>Negotiate</b>	Select the COM port that requires baud rate negotiation and click <b>Negotiate</b> . The selected port will negotiate the baud rate with the inverter, and the maximum baud rate is 38400 bit/s.
<b>Reset to 9600 bit/s</b>	If the communication between the SmartMGC and the inverter is good enough, you can click <b>Reset to 9600 bit/s</b> to reset the baud rate to 9600 bit/s.
<b>Port</b>	Specifies the COM port.
<b>Negotiation Status</b>	Displays the status of baud rate negotiation between the current interface and the inverter.
<b>Protocol Type</b> <sup>[1]</sup>	Retain the default value or change it as required.
<b>Baud Rate</b>	
<b>Parity</b>	
<b>Stop Bit</b>	
[1]: If the inverter uses both the MBUS and RS485 communications for fast grid scheduling, set <b>Protocol Type</b> to <b>Modbus-Control</b> .	

Table 6-82 Nighttime communication

Parameter	Description
<b>Silent mode at night</b>	Specifies whether to set <b>Silent mode at night</b> to <b>Enable</b> . In the silent mode at night, the SmartMGC does not communicate with the inverter, and the inverter can enter the hibernation state.

Parameter	Description
Start time	This parameter is displayed when <b>Silent mode at night</b> is set to <b>Enable</b> . Set this parameter as required.
End time	
Wakeup interval	

Table 6-83 Feature parameters

Parameter	Description
Auto-adaptive baud rate for software update	Specifies whether to set <b>Auto-adaptive baud rate for software update</b> to <b>Enable</b> . The devices adjust the communication rate automatically through negotiation to improve data transmission efficiency.
RS485 device disconnection duration (min)	Specifies the disconnection duration of an RS485-based device.

### 6.6.2.5 MBUS

 NOTE

Path: **Set > Port Settings > MBUS**

Table 6-84 MBUS

Parameter	Description
Built-in MBUS	Specifies whether to set <b>Built-in MBUS</b> to <b>Enable</b> .
Communication data collection interval	This parameter is displayed when <b>Built-in MBUS</b> is set to <b>Enable</b> . Specifies the interval at which communication data is collected.

### 6.6.2.6 AI/DI

 NOTE

Path: **Set > Port Settings > AI/DI**

Table 6-85 AI/DI

Parameter	Description
AI/DI-1 mode	Select the AI or DI mode based on the actual interconnection.
AI/DI-2 mode	

Parameter	Description
AI/DI-3 mode	
AI/DI-4 mode	

### 6.6.2.7 PT/CT

#### NOTE

Path: **Set > Port Settings > PT/CT**

**Table 6-86** PT/CT

Parameter	Description
PT/CT sampling	Specifies whether to set <b>PT/CT sampling</b> to <b>Enable</b> .
PT/CT cable connection mode	This parameter is displayed when <b>PT/CT sampling</b> is set to <b>Enable</b> . Set this parameter to <b>Three-phase three-wire</b> or <b>Three-phase four-wire</b> based on the actual cable connection.
Primary voltage of grid PT	This parameter is displayed when <b>PT/CT sampling</b> is set to <b>Enable</b> . Voltage is sampled through the U_AC1 port. <ul style="list-style-type: none"> <li>If PT sampling is unavailable, set the primary and secondary voltages on the grid side based on the actual rated voltage on the grid side.</li> <li>If PT sampling is available, set the primary and secondary voltages on the grid side based on the actual specifications of the PT.</li> </ul>
Secondary voltage of grid PT	
Primary voltage of microgrid PT	This parameter is displayed when <b>PT/CT sampling</b> is set to <b>Enable</b> . Voltage is sampled through the U_AC2 port. <ul style="list-style-type: none"> <li>If PT sampling is unavailable, set the primary and secondary voltages on the microgrid side based on the actual rated voltage on the microgrid side.</li> <li>If PT sampling is available, set the primary and secondary voltages on the microgrid side based on the actual specifications of the PT.</li> </ul>
Secondary voltage of microgrid PT	
Primary current of CT	This parameter is displayed when <b>PT/CT sampling</b> is set to <b>Enable</b> . The I_AC port is connected to the CT to sample current. Set this parameter based on the actual specifications of the CT.
Secondary current of CT	
CT wiring direction	Set this parameter based on the actual cable connection.

Parameter	Description
<b>Secondary side current threshold</b>	This parameter is displayed when <b>MGCC mode</b> is set to <b>Enable</b> and <b>Scenario</b> is set to <b>On/Off-grid</b> . The threshold is used to determine whether there is current in the circuit. If the secondary current exceeds the threshold, the system determines that there is current in the circuit. Set the threshold to avoid the impact of zero drift. The setting must match the specifications of the external CT. An incorrect setting may trigger an alarm indicating that the switch position is abnormal.

## 6.6.3 Communications Protocol

### 6.6.3.1 Modbus

#### Client

- The SmartMGC can connect to the management system through Modbus TCP as a client.

 **NOTE**

- Path: **Set > Communications protocol > Modbus > Client > Management System**.
- The management system can be connected only through a WAN port or mobile network.

**Table 6-87** Management system

Parameter	Description
<b>Management system communication</b>	Specifies whether to set <b>Management system communication</b> to <b>Enable</b> . <ul style="list-style-type: none"> <li>If this parameter is set to <b>Enable (restricted)</b>, the SmartMGC can communicate with a third-party management system whose IP address is whitelisted.</li> <li>If this parameter is set to <b>Enable (unrestricted)</b>, the SmartMGC can communicate with a third-party management system whose IP address is valid.</li> </ul>
<b>Server</b>	Specifies the IP address or domain name of the management system. Set this parameter as required by referring to <b>B Management System Domain Names</b> .

Parameter	Description
Port	Set this parameter as required by referring to <a href="#">A Port Numbers</a> .
TLS encryption	<ul style="list-style-type: none"> <li>• <b>Enable:</b> Data exchanged between the SmartMGC and the management system is encrypted.</li> <li>• <b>Disable:</b> Data exchanged between the SmartMGC and the management system is not encrypted, which poses security risks.</li> </ul>
TLS version	This parameter is displayed when <b>TLS encryption</b> is set to <b>Enable</b> . It specifies the TLS version. You are advised to select TLS1.2 or later.
Secondary challenge authentication	<ul style="list-style-type: none"> <li>• Specifies whether to set <b>Secondary challenge authentication</b> to <b>Enable</b>. The default value is <b>Enable</b>. The SmartMGC and management system perform password authentication.</li> <li>• After the first successful authentication, the management system and SmartMGC change the authentication password. If the management system or SmartMGC is replaced, the connection cannot be set up. In this case, you need to click <b>Reset authentication password</b> to reset the authentication password.</li> </ul>
Management system status	Displays the current status of the management system. If the SmartMGC cannot connect to the management system, rectify the fault based on the current status by referring to <a href="#">Table 6-88</a> .

**Table 6-88** Troubleshooting instructions for management system connection failure

Management System Status	Possible Causes	Troubleshooting
<b>Closed by peer</b>	<ul style="list-style-type: none"> <li>• The management system is not running or the port is not enabled.</li> <li>• The management system receives a data timeout response and disable the connection.</li> <li>• The firewall blocks the connection.</li> </ul>	<ol style="list-style-type: none"> <li>1. Check whether the management system is started.</li> <li>2. Check whether the IP address and port of the management system are correctly set.</li> <li>3. Check the firewall settings of the client and server.</li> </ol>

Management System Status	Possible Causes	Troubleshooting
<b>Disconnected abnormally</b>	The SmartMGC does not receive service data from the management system within 30s.	The SmartMGC will attempt to reconnect. No action is required.
<b>Port unreachable</b>	The SmartMGC cannot connect to the management system because the server or port is incorrectly set.	<ol style="list-style-type: none"> <li>1. Check whether the management system is started successfully.</li> <li>2. Check whether the IP address, domain name, or port of the management system is correctly set.</li> <li>3. If the SmartMGC uses 4G for communication, check whether the 4G card is properly installed, and whether the SIM card is in arrears or the traffic is used up.</li> <li>4. If the SmartMGC uses FE for communication, check whether the FE cable is properly connected to the network inside the plant.</li> </ol>
<b>Peer certificate verification failed</b>	<ul style="list-style-type: none"> <li>• The local certificate and peer certificate do not match the CA.</li> <li>• Failed to verify the peer certificate validity period.</li> </ul>	Check whether the SmartMGC certificate matches the management system certificate or whether the certificate has expired.
<b>Local certificate abnormal</b>	The SmartMGC fails to load the local certificate.	<p>Check whether the certificate issued by the customer has been replaced onsite.</p> <ul style="list-style-type: none"> <li>• If yes, import the certificate again.</li> <li>• If no, restore the default settings.</li> </ul>
<b>Domain name resolution failed</b>	<ul style="list-style-type: none"> <li>• The IP address of the DNS server is incorrectly set.</li> <li>• The address of the management system is incorrectly set.</li> </ul>	Check whether the IP address of the DNS server and the address of the management system server are correctly set.

Management System Status	Possible Causes	Troubleshooting
<b>Server unreachable</b>	The SmartMGC cannot connect to the management system because the server or port is incorrectly set.	<ol style="list-style-type: none"> <li>1. Check whether the management system is started successfully.</li> <li>2. Check whether the IP address, domain name, or port of the management system is correctly set.</li> <li>3. If the SmartMGC uses 4G for communication, check whether the 4G card is properly installed, and whether the SIM card is in arrears or the traffic is used up.</li> <li>4. If the SmartMGC uses FE for communication, check whether the FE cable is properly connected to the network inside the plant.</li> </ol>
<b>Secondary challenge authentication failed</b>	The account or password for second challenge authentication is incorrect.	<ol style="list-style-type: none"> <li>1. If the SmartMGC or management system has been replaced, reset the password for second challenge authentication.</li> <li>2. If the connection still fails, disable the second challenge authentication function.</li> </ol>

- The SmartMGC can connect to a third-party management system through Modbus TCP as a client.

 **NOTE**

Path: **Set > Communications protocol > Modbus > Client > Management System-1**

**Table 6-89** Management system-1

Parameter	Description
<b>Management system-1 communication</b>	Specifies whether to set <b>Management System-1</b> to <b>Enable</b> .
<b>Management system 1 IP address</b>	Specifies the IP address of the management system.

Parameter	Description
Port	Set this parameter as required by referring to <a href="#">A Port Numbers</a> .
Address mode	If the communication address of the connected device is unique, you are advised to select <b>Communications Address</b> . Otherwise, you must select <b>Logical Address</b> .
TLS encryption	<ul style="list-style-type: none"><li>• <b>Enable</b>: Data exchanged between the SmartMGC and the management system is encrypted.</li><li>• <b>Disable</b>: Data exchanged between the SmartMGC and the management system is not encrypted, which poses security risks.</li></ul>
TLS version	This parameter is displayed when <b>TLS encryption</b> is set to <b>Enable</b> . It specifies the TLS version. You are advised to select TLS1.2 or later.
Remote permission	<ul style="list-style-type: none"><li>• <b>Monitoring only</b>: The third-party management system is only allowed to read information about the SmartMGC.</li><li>• <b>Management (permanent authorization)</b>: The third-party management system is allowed to read and write information about the SmartMGC.</li><li>• <b>Management (temporary authorization)</b>: The third-party management system is allowed to read and write information about the SmartMGC within the authorization period. If the authorization period expires, the third-party management system is only allowed to read information about the SmartMGC but not allowed to write information.</li></ul>
Management system status	Displays the current status of the management system. If the SmartMGC cannot connect to the management system, rectify the fault based on the current status by referring to <a href="#">Table 6-88</a> .

## Server

The SmartMGC can connect to a third-party management system through Modbus TCP as a server.

### NOTE

Path: **Set > Communications protocol > Modbus > Communications protocol > Server**

Table 6-90 Server

Parameter	Description
Modbus TCP service	Specifies whether to set <b>Modbus TCP service</b> to <b>Enable</b> .
Modbus TCP/Client $\alpha$ <sup>[1]</sup>	This parameter is displayed when <b>Modbus TCP service</b> is set to <b>Enable (restricted)</b> . It specifies the IP address of the client.
Logger address	Specifies the slave address of the SmartMGC.
No response from disconnected device	Specifies whether to set <b>No response from disconnected device</b> to <b>Enable</b> .
[1]: $\alpha = 1-5$	

### 6.6.3.2 IEC104

The SmartMGC can connect to a third-party management system through the IEC 104 protocol. The third-party management system receives array information through teleindication and telemetry, and sets array parameters through telecontrol and teleadjust.

#### NOTICE

- The IEC 104 protocol does not have a security authentication mechanism. Data transmitted through the IEC 104 protocol is not encrypted, which may cause data leakage and control permission theft. Exercise caution when using the IEC 104 protocol. Users are liable for any loss caused by connecting to a third-party management system (non-secure protocol) using the IEC 104 protocol.
- SmartMGC establishes a communication connection in public mode, which is set in **General Service**.
- The SmartMGC establishes a communication connection with the management system of the specified IP address (that is, in whitelist mode), which is set in **Custom Service**.
- After setting the IEC 104 protocol parameters, you can perform data check by referring to [6.7.4.3 Data Check](#).
- If you need to forward energy data to a northbound device, use the **Telemetry** mode.

#### 6.6.3.2.1 General Service

### Parameter Settings

#### NOTE

Path: **Set > Communications protocol > IEC104 > General Service > Parameter Settings**

**Table 6-91** Parameter settings

Parameter	Description
<b>IEC104 Service</b>	Specifies whether to set <b>IEC104</b> to <b>Enable</b> .

**Table 6-92** Slave

Parameter	Description
<b>Port</b>	You are advised to use <b>2404</b> . If there are any special requirements, change the value as required.
<b>Public address</b>	Set this parameter as required. If the public addresses are inconsistent, the subsequent grid dispatch and inverter startup/shutdown control will be affected.
<b>Push interval</b>	Specifies the interval for the SmartMGC to push data to a third-party management system over IEC 104. If this parameter is set to 0s, there is no limit on the interval at which the SmartMGC sends data over IEC 104.
<b>Telemetry forwarding deadband</b>	When the telemetry data change exceeds this value, the change is reported.

**Table 6-93** Information object address range

Parameter	Description
<b>Teleindication address</b>	<ul style="list-style-type: none"> <li>• The start address of a signal must be less than or equal to the end address. The address ranges of different signals cannot overlap.</li> <li>• Value range:                             <ul style="list-style-type: none"> <li>- <b>Teleindication address:</b> 1-16384</li> <li>- <b>Telemetry address:</b> 16385-24576</li> <li>- <b>Telecontrol address:</b> 24577-25088</li> <li>- <b>Teleadjust address:</b> 25089-25600</li> </ul> </li> </ul>
<b>Telemetry address</b>	
<b>Telecontrol address</b>	
<b>Teleadjust address</b>	

## Address Range

### NOTE

- Path: **Set > Communications protocol > IEC104 > General Service > Address Range.**
- Download the latest software version document from the [Smart PV Software Download Center](#), decompress the package, and view the **IEC 104 Forwarding Protocol Interface Description** file. Search for the corresponding device model in the file, and check the telemetry, teleindication, telecontrol, and teleadjust signal No. information of the corresponding device model.
- Signal No. configuration:
  - End value of signal No.  $\geq$  Start value of signal No. + Signal No. quantity - 1
  - The signal No. quantity (that is, End value - Start value) may be different from the actual signal No. quantity in the device. To facilitate calculation, you are advised to round up the end value of signal No. when setting the end value. For example, if the actual telemetry signal No. quantity of device a is 15, you can configure 20 telemetry signal numbers for device a.
- **Method 1: manual configuration**
  - a. Set the start and end values of **Teleindication, Telemetry, Telecontrol, and Teleadjust** for each device.
  - b. Click **Submit**.
- **Method 2: configuration import**
  - a. Click **Export** and select **Address Range** or **Full signal table** to export the information file.
  - b. Edit the information file in Excel.
  - c. Click **Import Address Range** to access the **Import** dialog box.
  - d. Select the address range information file that has been edited and click **Import**.
  - e. Click **Submit**.
- **Method 3: one-click configuration**
  - a. Click **Configure** to access the **Configure** dialog box.
  - b. Set the range values of **Teleindication, Telemetry, Telecontrol, and Teleadjust**, and click **OK**.
  - c. Click **Submit**.

### NOTE

- Check whether all of signal No. have been allocated to each device. If the addresses of multiple devices are the same, some of signal No. may not be allocated to these devices. You are advised to change the device addresses and click **Submit**.
  - Check whether some of signal No. allocated are changed greatly. If the device addresses change greatly, the signal No. will be changed greatly. You are advised to manually change the signal No. ranges.
- **Address range setting (example)**

### NOTE

Assume that an array has one SmartMGC, one ESS, and one inverter.

**Table 6-94** Signal No. quantity

Device Name	Teleindication Signal No. Quantity	Telemetry Signal No. Quantity	Telecontrol Signal No. Quantity	Teleadjust Signal No. Quantity
Logger	48	89	14	20
ESS	184	73	3	0
Inverter	83	32	3	0

**Table 6-95** Signal No. setting

Device Name	No.	Teleindication		Telemetry		Telecontrol		Teleadjust	
		Start	End	Start	End	Start	End	Start	End
Logger	0	0	50	0	100	0	20	0	20
ESS	1	51	250	101	200	21	30	0	0
Inverter	2	251	350	201	250	31	40	0	0

## Forwarding Table

### NOTE

Path: **Set > Communications protocol > IEC104 > General Service > Forwarding Signal Table**

**Step 1** Choose **Device Type**.

You can click **Restore defaults** to restore the device signals to the default values.

**Step 2** Select **Teleindication**, **Telemetry**, **Telecontrol**, or **Teleadjust**.

**Step 3** Add, delete, or modify signals.

**Step 4** Click **Submit**.

----End

### 6.6.3.2.2 Custom Service

#### Select Service

You can synchronize and copy the parameters of a custom service.

### NOTE

Path: **Set > Communications protocol > IEC104 > Custom Service > Select Service**

- **Synchronizing parameters**
  - a. Select the **Custom service  $\alpha$**  whose parameters are to be synchronized.
  - b. Click **Sync Parameter** to access the **Sync Parameter** dialog box.
  - c. Select the parameter source **Custom service  $\beta$** .
  - d. Click **OK**.
- **Copying parameters**
  - a. Select the parameter source **Custom service  $\alpha$**  whose parameters have been set.
  - b. Click **Copy Parameter** to access the **Copy Parameter** dialog box.
  - c. Select **Custom service  $\beta$**  whose parameters need to be copied.
  - d. Click **OK**.

 **NOTE**

Here,  $\alpha$  or  $\beta$  = 1-20

## Parameter Settings

 **NOTE**

Path: **Set > Communications protocol > IEC104 > Custom Service > Parameter Settings**

**Table 6-96** Parameter settings

Parameter	Description
<b>IEC104 Service</b>	Specifies whether to set <b>IEC104</b> to <b>Enable</b> .

**Table 6-97** Slave

Parameter	Description
<b>Port</b>	You are advised to use <b>2404</b> . If there are any special requirements, change the value as required.
<b>Public address</b>	Set this parameter as required. If the public addresses are inconsistent, the subsequent grid dispatch and inverter startup/shutdown control will be affected.
<b>Push interval</b>	Specifies the interval for the SmartMGC to push data to a third-party management system over IEC 104. If this parameter is set to 0s, there is no limit on the interval at which the SmartMGC sends data over IEC 104.
<b>Telemetry forwarding deadband</b>	When the telemetry data change exceeds this value, the change is reported.

**Table 6-98 Master**

Parameter	Description
IP- $\alpha$ <sup>[1]</sup>	Set the IP address of the interconnected device. It is recommended that the IP addresses of the master and slave devices be in the same network segment.
Active/Standby mode	<ul style="list-style-type: none"> <li>• <b>Active+Active:</b> All links can send data and respond to commands.</li> <li>• <b>Active+Standby:</b> The active link sends data and responds to commands, and the standby link only transmits keepalive messages.</li> </ul>
[1]: $\alpha = 1-4$	

**Table 6-99 Information object address range**

Parameter	Description
Teleindication address	<ul style="list-style-type: none"> <li>• The start address of a signal must be less than or equal to the end address. The address ranges of different signals cannot overlap.</li> <li>• Value range: <ul style="list-style-type: none"> <li>- <b>Teleindication address:</b> 1-16384</li> <li>- <b>Telemetry address:</b> 16385-24576</li> <li>- <b>Telecontrol address:</b> 24577-25088</li> <li>- <b>Teleadjust address:</b> 25089-25600</li> </ul> </li> </ul>
Telemetry address	
Telecontrol address	
Teleadjust address	

## Address Range

### NOTE

- Path: **Set > Communications protocol > IEC104 > Custom Service > Address Range**
- Download the latest software version document from the [Smart PV Software Download Center](#), decompress the package, and view the **IEC 104 Forwarding Protocol Interface Description** file. Search for the corresponding device model in the file, and check the telemetry, teleindication, telecontrol, and teleadjust signal No. information of the corresponding device model.
- Signal No. configuration:
  - End value of signal No.  $\geq$  Start value of signal No. + Signal No. quantity - 1
  - The signal No. quantity (that is, End value - Start value) may be different from the actual signal No. quantity in the device. To facilitate calculation, you are advised to round up the end value of signal No. when setting the end value. For example, if the actual telemetry signal No. quantity of device  $\alpha$  is 15, you can configure 20 telemetry signal numbers for device  $\alpha$ .
- **Method 1: manual configuration**
  - a. Set the start and end values of **Teleindication**, **Telemetry**, **Telecontrol**, and **Teleadjust** for each device.

- b. Click **Submit**.
- **Method 2: configuration import**
  - a. Click **Export** and select **Address Range** or **Full signal table** to export the information file.
  - b. Edit the information file in Excel.
  - c. Click **Import Address Range** to access the **Import** dialog box.
  - d. Select the address range information file that has been edited and click **Import**.
  - e. Click **Submit**.
- **Method 3: one-click configuration**
  - a. Click **Configure** to access the **Configure** dialog box.
  - b. Set the range values of **Teleindication**, **Telemetry**, **Telecontrol**, and **Teleadjust**, and click **OK**.
  - c. Click **Submit**.

 **NOTE**

- Check whether all of signal No. have been allocated to each device. If the addresses of multiple devices are the same, some of signal No. may not be allocated to these devices. You are advised to change the device addresses and click **Submit**.
  - Check whether some of signal No. allocated are changed greatly. If the device addresses change greatly, the signal No. will be changed greatly. You are advised to manually change the signal No. ranges.
- **Address range setting (example)**

 **NOTE**

Assume that an array has one SmartMGC, one ESS, and one inverter.

**Table 6-100** Signal No. quantity

Device Name	Teleindication Signal No. Quantity	Telemetry Signal No. Quantity	Telecontrol Signal No. Quantity	Teleadjust Signal No. Quantity
Logger	48	89	14	20
ESS	184	73	3	0
Inverter	83	32	3	0

**Table 6-101** Signal No. setting

Device Name	N o.	Teleindicati on		Telemetry		Telecontrol		Teleadjust	
		Start	End	Start	End	Start	End	Start	End
Logger	0	0	50	0	100	0	20	0	20
ESS	1	51	250	101	200	21	30	0	0
Inverter	2	251	350	201	250	31	40	0	0

## Forwarding Table

 **NOTE**

Path: **Set > Communications protocol > IEC104 > Custom Service > Forwarding Signal Table**

**Step 1** Choose **Device Type**.

You can click **Restore defaults** to restore the device signals to the default values.

**Step 2** Select **Teleindication**, **Telemetry**, **Telecontrol**, or **Teleadjust**.

**Step 3** Add, delete, or modify signals.

**Step 4** Click **Submit**.

----End

### 6.6.3.3 GOOSE

GOOSE is a communications protocol used in power systems. It is mainly used for real-time data transmission and fast transfer of control commands.

 **NOTE**

Path: **Set > Communications protocol > GOOSE**

**Table 6-102** Basic parameters

Parameter	Description
<b>GOOSE</b>	Specifies whether to set <b>GOOSE</b> to <b>Enable</b> .
<b>Data transmission</b>	This parameter is displayed when <b>GOOSE</b> is set to <b>Enable</b> . It specifies whether to set <b>Data transmission</b> to <b>Enable</b> .
<b>Data receiving</b>	This parameter is displayed when <b>GOOSE</b> is set to <b>Enable</b> . It specifies whether to set <b>Data receiving</b> to <b>Enable</b> .

Parameter	Description
<b>Network port</b>	This parameter is displayed when <b>GOOSE</b> is set to <b>Enable</b> . You can set a network port for GOOSE communication based on the actual cable connection. Multiple network ports can be used for GOOSE communication, and if configured, they will be used to report and receive GOOSE packets.
<b>Device status</b>	This parameter is displayed when <b>GOOSE</b> is set to <b>Enable</b> . Specifies the status of the device. Only packets that match the device status are received and reported.
<b>Device name</b>	Displays the type and name of the device.
<b>Device type</b>	
<b>Controller 1 type</b>	Displays the type and name of the controller connected through GOOSE.
<b>Controller 1 name</b>	
<b>Controller 2 type</b>	
<b>Controller 2 name</b>	

**Table 6-103** Configuration file

Parameter	Description
<b>Configuration status</b>	Displays the current configuration status.
<b>Last import time</b>	<ul style="list-style-type: none"> <li>• <b>Unavailable:</b> No configuration file has been successfully imported</li> <li>• <b>Normal:</b> A configuration file has been successfully imported. If a new configuration file is successfully imported again, the new configuration file replaces the old one, and <b>Last import time</b> is updated. If the new configuration file fails to be imported again, the old configuration file is retained, and <b>Last import time</b> is not updated.</li> </ul>

 **NOTE**

- Download the latest software release document from the [Smart PV Software Download Center](#) file, decompress the package, and view the **GOOSE Protocol Interface Description** file to check the GOOSE interconnection description and interface description.
- You can contact the vendor to obtain the CID files of the SmartMGC controller. Compress the CID files into a.zip configuration package and import the package.
- Click **Export** to export the CID and ICD files of the SmartMGC. If the CID file of the controller has been successfully imported, it will be exported.

### 6.6.3.4 HTTPS

 NOTE

Path: **Set > Communications protocol > HTTPS**

**Table 6-104** HTTPS

Parameter	Description
Port	You can select <b>443</b> or <b>1443</b> . If the port is changed, you need to log in again.

## 6.6.4 Grid Connection Control

### 6.6.4.1 Active Power

#### Description

You can set the active power control mode of an array on the SmartMGC to meet the requirements of the grid and loads.

[Table 6-105](#) describes the active power control modes supported by the SmartMGC.

**Table 6-105** Active power control modes

Control Mode	Application Scenario	Overview
<b>Unlimited</b>	This mode applies to the scenario where no power limitation is required at the grid connection point.	The active power output of an array is not limited. In this mode, the inverter runs at full load, and the PCS runs at limited power based on the ESS control policy.  This mode is mutually exclusive with other active power control modes.
<b>Scheduling via DI</b>	This mode applies to the scenario where the grid DI controller needs to deliver power limitation commands.	This function applies only to some areas in Europe, such as Germany. According to the local standards, the grid dispatch signals need to be transmitted through a ripple control receiver (RCR) over dry contact signals.  The SmartMGC receives RCR dispatch commands through the DI port and limits the active power output of an array at the specified derating ratio.

Control Mode	Application Scenario	Overview
<b>Remote scheduling</b>	This mode applies to the scenario where the northbound controller delivers the power limit value through the SmartMGC.	The SmartMGC receives a dispatch command from the northbound controller through Modbus-TCP, GOOSE, or IEC 104, and derates the active power according to the command.
<b>Limited feed-in</b>	This mode applies to the scenario where the power at the grid connection point is controlled by the SmartMGC.	The SmartMGC detects the active power at the grid connection point in real time and dynamically adjusts the active power to ensure that the output power of an array to the power grid does not exceed the threshold specified by the power grid company.
<b>Remote output control</b>	According to the Japanese standard, the upper limit of inverter power needs to be controlled by the remote output control server.	Remote output control applies only to Japan. The SmartMGC obtains the time and dispatch information from the server of the power grid company, and delivers dispatch commands corresponding to the current time to the inverter to control its active power.

The system supports the combination of multiple active power control modes. If multiple active power control modes are triggered at the same time, the policy with the lowest power limit takes effect first. As shown in [Figure 6-14](#), both remote scheduling and limited feed-in are activated.

**Figure 6-14** Combination of active power control modes (example)

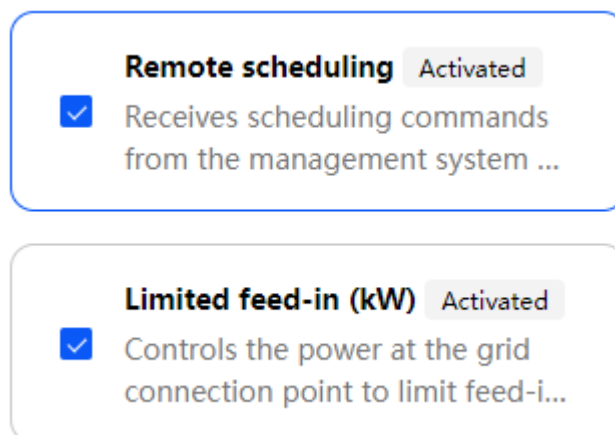

### 6.6.4.1.1 Unlimited

#### Description

The active power output of an array is not limited. In this mode, the inverter runs at full load, and the PCS runs at limited power based on the ESS control policy.

This mode is mutually exclusive with other active power control modes.

#### Procedure

**Step 1** Enable remote power scheduling for the inverter and PCS.

- Choose **Monitoring > ESS > Running Parameters** and set **Remote Scheduling** to **Enable**.
- Choose **Monitoring > Inverter > Running Parameters** and set **Remote Scheduling** to **Enable**.

**Step 2** Activate the active power control mode **Unlimited**.

1. Choose **Set > Grid Connection Control > Active Power**. The **Active power control mode** page is displayed.
2. Select **Unlimited** and click **OK**.

If this option cannot be selected, deselect other options and try again.

----End

### 6.6.4.1.2 Scheduling via DI

#### Description

This function applies only to some areas in Europe, such as Germany. According to the local standards, the grid dispatch signals need to be transmitted through a ripple control receiver (RCR) over dry contact signals.

The SmartMGC receives RCR dispatch commands through the DI port and limits the active power output of an array at the specified derating ratio.

The SmartMGC matches the preset DI1–DI4 dry contact signals (closed/open) based on the dry contact signals (closed/open) received by the DI1–DI4 ports, and limits the active power output of an array at the preset derating ratio.

**Figure 6-15** RCR cable connection

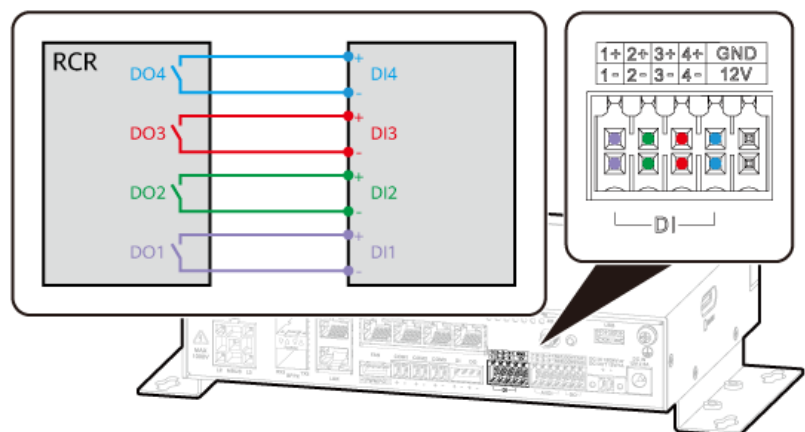

S001152



**NOTICE**

Ensure that the SmartMGC is properly connected to the RCR and the DI1–DI4 ports of the SmartMGC are not occupied by other services, to prevent scheduling via DI from being affected.

**Procedure**

- Step 1** Enable remote power scheduling for the inverter and PCS.
- Choose **Monitoring > ESS > Running Parameters** and set **Remote Scheduling** to **Enable**.
  - Choose **Monitoring > Inverter > Running Parameters** and set **Remote Scheduling** to **Enable**.
- Step 2** Activate the active power control mode **Scheduling via DI**.
- Choose **Set > Grid Connection Control > Active Power**. The **Active power control mode** page is displayed.
  - Select **Scheduling via DI** and click **OK**.  
If this option cannot be selected, deselect **Unlimited** and try again.
- Step 3** Set **Scheduling via DI** parameters.

**Figure 6-16** Scheduling via DI (example)

No.	DI1	DI2	DI3	DI4	Percentage (%)	Operation
1	Closed	Open	Closed	Open	80.0	 
2	Open	Open	Closed	Closed	90.0	 

**Table 6-106** Scheduling via DI

Parameter	Description
<b>DI1</b>	Specifies a DI1–DI4 signal combination according to the power grid company or RCR device description. The DI signal combination must be unique.
<b>DI2</b>	
<b>DI3</b>	
<b>DI4</b>	
<b>Percentage</b>	Specifies the active power limit in percentage. <b>Figure 6-16</b> shows an example. <ul style="list-style-type: none"> <li>When the signals received by ports DI1–DI4 of the SmartMGC are "closed–open–closed–open", the array outputs power equivalent to 80% of the rated power.</li> <li>When the signals received by ports DI1–DI4 of the SmartMGC are "open–open–closed–closed", the array outputs power equivalent to 90% of the rated power.</li> </ul>

**Step 4** After the parameters are set, click **Submit**.

----End

### 6.6.4.1.3 Remote Scheduling

#### Description

The SmartMGC receives a dispatch command from the northbound controller through Modbus-TCP, GOOSE, or IEC 104, and derates the active power according to the command.

#### NOTICE

After receiving a dispatch command from the northbound controller, the SmartMGC automatically activates the active power control mode **Remote Scheduling**.

#### Procedure

**Step 1** Enable remote power scheduling for the inverter and PCS.

- Choose **Monitoring > ESS > Running Parameters** and set **Remote Scheduling** to **Enable**.
- Choose **Monitoring > Inverter > Running Parameters** and set **Remote Scheduling** to **Enable**.

**Step 2** Activate the active power control mode **Remote Scheduling**.

1. Choose **Set > Grid Connection Control > Active Power**. The **Active power control mode** page is displayed.
2. Select **Remote Scheduling** and click **OK**.  
If this option cannot be selected, deselect **Unlimited** and try again.

**Step 3** Set **Remote Scheduling** parameters.

- **Scenario 1: Remote scheduling disabled**

In this scenario, the SmartMGC does not deliver a dispatch command to an array from the northbound controller. The array continues to output active power according to the dispatch command received before this scenario is triggered or other active power control modes (when a combination of active power control modes is used and other control modes are triggered).

Parameter	Description
Scheduling policy	Set this parameter to <b>Disable</b> .

- **Scenario 2: Even allocation of active power based on a remote dispatch command**

In this scenario, the SmartMGC evenly allocates the target power value in the dispatch command to each inverter or allocates the target power value to each PCS based on SOC balancing.

Parameter	Description
<b>Scheduling policy</b>	Set this parameter to <b>Policy 1</b> .
<b>Adjustment coefficient</b>	If the adjustment coefficient is set, the target power value will be sent to the devices after being multiplied by the preset coefficient.  The default value 1.000 is recommended. If you need to modify the value, contact technical support.

- **Scenario 3 (only for PV-only networking): Differentiated allocation of active power based on a remote dispatch command**

In this scenario, the SmartMGC differentiates the target power value in the dispatch command and allocates the power value to each inverter based on the capability of each inverter.

Parameter	Description
<b>Scheduling policy</b>	Set this parameter to <b>Policy 2</b> .
<b>Fast closed-loop</b>	Enables or disables the fast closed-loop power control function.  After this function is enabled, when the dispatch command from the northbound controller changes, the SmartMGC can quickly implement closed-loop power control based on the data collected by its PT/CT port or the data sent by the Huawei-developed STS, shortening the target power response time.
<b>Adjustment interval for fast closed-loop</b>	Specifies the interval for <b>Fast closed-loop</b> . The fast closed-loop control function will be completed within the interval.
<b>Slow closed-loop</b>	If the power generation capabilities of inverters in an array are inconsistent (for example, in mountainous areas or in cloudy weather), enabling this function allows the SmartMGC to implement differentiated allocation based on inverters' power generation capabilities based on the data sent back through real-time communication, improving the overall energy yield of the system.
<b>Adjustment interval for slow closed-loop</b>	Specifies the interval for <b>Slow closed-loop</b> . The slow closed-loop control function will be completed within the interval.

Parameter	Description
<b>Adjustment deadband</b>	Specifies the allowed percentage of the adjustment deviation value to the rated output capacity. To prevent frequent active power fluctuations, if the difference between the target power in the dispatch command and the actual output power of the array is within the adjustment deadband, the system allows the deviation within the range and maintains the current active power output.
<b>Closed-loop overshoot limit</b>	To prevent excessive active power fluctuations, this parameter can be used to restrict the upper limit of power fluctuations at the grid connection point when the fast closed-loop mode is enabled. The default value 3.0 is recommended. If you need to modify the value, contact technical support.

**Step 4** (Optional) Set communication abnormality protection mechanisms.

When the communication between the SmartMGC and the northbound controller is abnormal, the following two mechanisms can be used to protect the devices.

- **Shut down upon active power signal timeout**

If remote dispatch commands between the SmartMGC and the northbound controller are interrupted, the SmartMGC shuts down the devices.

Parameter	Description
<b>Shut down upon active power signal timeout</b>	Enables or disables the function of shutdown upon active power signal timeout.
<b>Active power signal timeout threshold for shutdown</b>	Specifies the time for determining active power signal timeout. If the SmartMGC has not received remote dispatch commands for a period longer than the specified time, the system determines that the communication is abnormal and shuts down the devices.
<b>Start up upon recovery from active power signal timeout</b>	Enables or disables the function of automatic startup upon recovery from active power signal timeout. If this function is enabled, the system starts devices when the active power signal timeout of the SmartMGC is rectified.

- **Limit active power upon communication timeout**

If remote dispatch commands between the SmartMGC and the northbound controller are interrupted, the SmartMGC derates the active power of devices.

Parameter	Description
<b>Limit active power upon communication timeout</b>	Enables or disables the function of limiting active power upon communication timeout.
<b>Communication timeout threshold for limiting active power</b>	Specifies the time for determining active power signal timeout. If the SmartMGC has not received remote dispatch commands for a period longer than the specified time, the system determines that the communication is abnormal and limits the power.
<b>PV active power upon communication timeout</b>	After the system determines that the communication is abnormal, the system limits the active power of inverters based on the parameter value.
<b>ESS active power upon communication timeout</b>	After the system determines that the communication is abnormal, the system limits the active power of PCSs based on the parameter value.

 **NOTE**

- If no communication abnormality protection mechanism is set, the SmartMGC continues to execute the dispatch command before the communication between the SmartMGC and the northbound controller is abnormal.
- The two communication abnormality protection mechanisms can be combined. To make both mechanisms take effect, ensure that **Communication timeout threshold for limiting active power** is less than **Active power signal timeout threshold for shutdown**.

**Step 5** After the parameters are set, click **Submit**.

----End

#### 6.6.4.1.4 Limited Feed-in

### Description

The SmartMGC detects the active power at the grid connection point in real time and dynamically adjusts the active power to ensure that the output power of an array to the power grid does not exceed the threshold specified by the power grid company.

Before enabling this function, ensure that the PT/CT sampling port is correctly connected to the PT/CT or ensure that the power meter is correctly connected to the SmartMGC. When adding a power meter, set **Meter usage** to **Feed-in meter**.

 **NOTE**

In Thailand and Spain, this function can be enabled only when a power meter is used.

In some regions, a circuit breaker must be installed at the grid connection point, as shown in **Figure 6-17**. If power feed-in occurs, the SmartMGC turn off the circuit breaker through the DO port to ensure that the specifications are met.

**Figure 6-17** Circuit breaker drive wiring

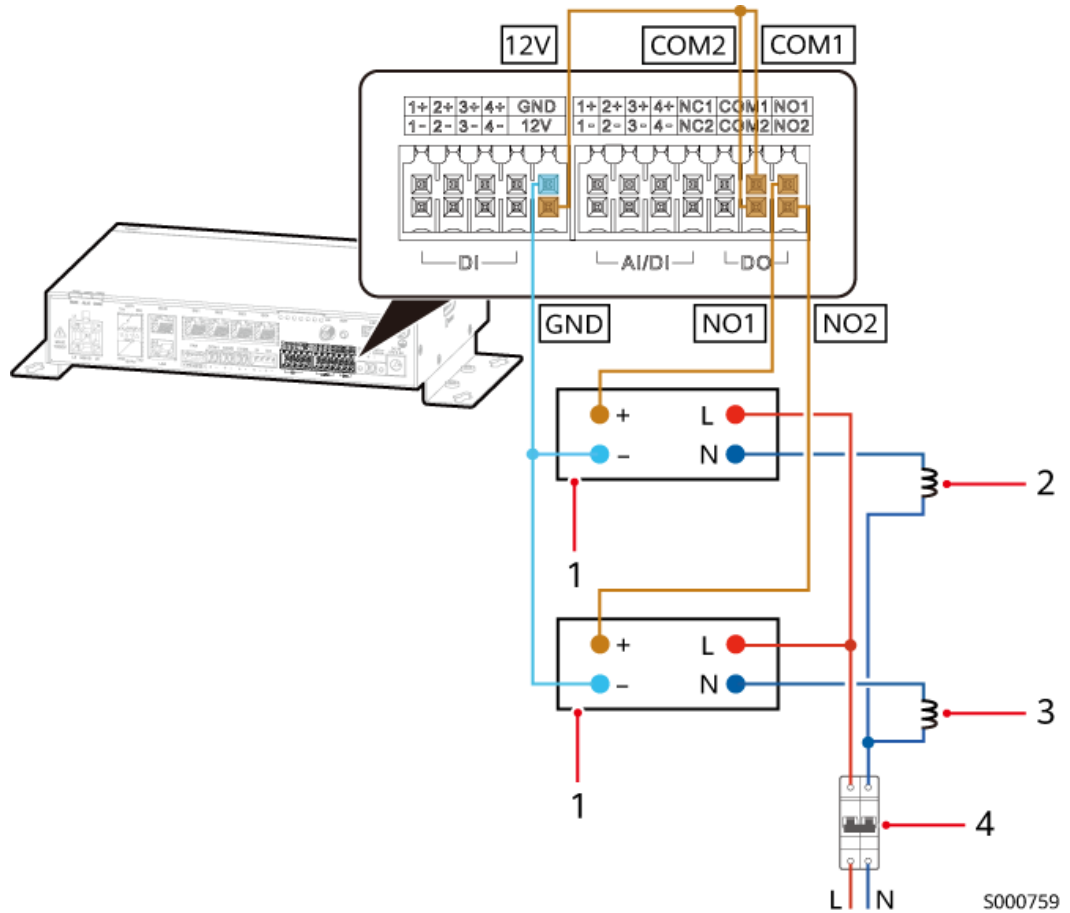

- (1) Intermediate relay (power drive device for switching on or off the circuit breaker)
- (2) Drive coil for switching on the circuit breaker
- (3) Drive coil for switching off the circuit breaker
- (4) Air circuit breaker

**NOTE**

You can check the circuit breaker status (on or off) using the DI port on the SmartMGC.

**Procedure**

**Step 1** Enable remote power scheduling for the inverter and PCS.

- Choose **Monitoring > ESS > Running Parameters** and set **Remote Scheduling** to **Enable**.

- Choose **Monitoring > Inverter > Running Parameters** and set **Remote Scheduling** to **Enable**.

**Step 2** Activate the active power control mode **Limited feed-in**.

1. Choose **Set > Grid Connection Control > Active Power**. The **Active power control mode** page is displayed.
2. Select **Limited feed-in** and click **OK**.

If this option cannot be selected, deselect **Unlimited** and try again.

**Step 3** Set **Limited feed-in** parameters.

**Table 6-107** Basic parameters

Parameter	Description
<b>Limitation mode</b>	<p>Specifies the power limiting mode based on the power limiting criteria of the local power grid company. If the power of each phase at the grid connection point is limited, select <b>Single-phase power</b>. Otherwise, select <b>Total power</b>.</p> <ul style="list-style-type: none"> <li>• <b>Total power</b>: The total power at the grid connection point is limited.</li> <li>• <b>Single-phase power</b>: The power of each phase at the grid connection point is limited.</li> </ul>
<b>Time-based limit</b>	<p>Specifies whether to set <b>Time-based restrictions</b> to <b>Enable</b>. After the parameter is set to <b>Enable</b>, you can set different values of <b>Maximum grid feed-in power</b> for different time segments. The control priority of <b>Maximum grid feed-in power</b> in a time segment configured is higher than that of <b>Maximum grid feed-in power</b> in basic parameters. If this parameter is not set to <b>Enable</b> or the current time segment is not configured, the system uses <b>Maximum grid feed-in power</b> in basic parameters for control.</p>
<b>Maximum protection time</b>	<p>Specifies the maximum duration from the time when the SmartMGC detects power feed-in to the time when the device output power is adjusted to <b>Maximum grid feed-in power</b>.</p> <p>You are advised to set this parameter based on the maximum power feed-in duration allowed by the power grid company. If the maximum power feed-in duration allowed by the power grid company is 2s, set this parameter to 2s.</p>
<b>Power raising threshold</b>	<p>This parameter is set to prevent the device output power from fluctuating repeatedly near the limit when the load power increases. The recommended value is 1%–2% Pn. Pn indicates the total rated power of the device.</p>

Parameter	Description
<b>three-phase unbalance control</b>	<p>This parameter is displayed when <b>Limitation mode</b> is set to <b>Single-phase power</b>.</p> <p>If the feed-in meter is a three-phase four-wire meter, you can control phase-level power dispatch separately to implement cost-effective dispatch.</p> <ul style="list-style-type: none"> <li>• <b>Enable</b>: separate control for three phases</li> <li>• <b>Disable</b>: joint control for three phases</li> </ul>
<b>Maximum grid feed-in power</b>	<p>Specifies the maximum power that a device can feed into the power grid.</p> <p>You are advised to set this parameter to 1% of the rated array power. If the value is less than the setting, the power at the grid connection point may fluctuate frequently. The maximum value of this parameter cannot exceed the feed-in power threshold allowed by the power grid company.</p> <p>Value range:</p> <ul style="list-style-type: none"> <li>• Maximum value: 50000</li> <li>• Minimum value: If <b>Demand limit</b> is set to <b>Active power limit</b> or <b>Apparent power limit</b>, the minimum value is determined by the value of <b>Maximum Peak Power</b> (you can view the value after choosing <b>Set &gt; Grid Connection Control &gt; Capacity/Demand Control</b>).</li> </ul>
<b>Start and End Time</b>	<p>This parameter is displayed when <b>Time-based limit</b> is set to <b>Enable</b>. It specifies the time window for the time-based limit. A maximum of 24 time segments can be set.</p> <p>Set <b>Maximum grid feed-in power</b> for different time segments and the time for repetition. The control priority of <b>Maximum grid feed-in power</b> in the time segments configured is higher than that of <b>Maximum grid feed-in power</b> in basic parameters.</p>
<b>Maximum grid feed-in power</b>	
<b>Repeat</b>	

**Step 4** (Optional) Set extended parameters for limited feed-in.

Set extended parameters if the SmartMGC needs to drive the circuit breaker to prevent power feed-in. If not involved, skip this step.

**Table 6-108** Extended parameters

Parameter	Description
<b>Switch control for zero feed-in</b>	Specifies whether the DO port is allowed to control switch-off.

Parameter	Description
<b>Switch-off control port</b>	Specifies the DO port for controlling switch-off. Click <b>Off</b> to verify the function of remotely switching off the circuit breaker by the SmartMGC.
<b>Switch-on control port</b>	Specifies the DO port for controlling switch-on. Click <b>On</b> to verify the function of remotely switching on the circuit breaker by the SmartMGC.
<b>Switch-off state feedback port</b>	Specifies the DI port that reports the switch-off state.
<b>Switch-on state feedback port</b>	Specifies the DI port that reports the switch-on state.

**Step 5** Click **Inverter/PCS Parameters** in the upper right corner of the page to set inverter or PCS parameters.

**Table 6-109** Inverter or PCS parameters

Parameter	Description
<b>Active power change gradient</b>	To ensure that the power can be quickly adjusted to the target in the feed-in control scenario, you need to set this parameter. You are advised to set this parameter to 1000%/s.
<b>Soft start time</b>	Specifies the duration for the inverter or PCS output power to gradually increase when the device starts. The inverter or PCS output power increases slowly, reducing the feed-in risk. You are advised to set this parameter to 20s.
<b>Power-on soft start time due to power grid faults</b>	Specifies the duration for the inverter or PCS output power to gradually increase when the inverter or PCS starts after the grid fault is rectified. The inverter or PCS output power increases slowly, reducing the feed-in risk. You are advised to set this parameter to 20s.
<b>Protection upon Communication Failure</b>	In the feed-in control scenario, the inverter or PCS automatically reduces the power to prevent feed-in when the inverter or PCS is disconnected from the SmartMGC. <ul style="list-style-type: none"> <li>● <b>Enable:</b> The inverter or PCS automatically reduces the power to prevent feed-in when it is disconnected from the SmartMGC.</li> <li>● <b>Disable:</b> Protection upon communication failure is disabled.</li> </ul>

Parameter	Description
<b>Communication disconnection duration</b>	This parameter is displayed when <b>Protection upon Communication Failure</b> is set to <b>Enable</b> . If communication between the inverter or PCS and the SmartMGC is interrupted beyond the duration specified by this parameter, it is considered as a failure. You are advised to set this parameter to 3s. (For the RD1699 grid code of Spain, you are advised to set this parameter to 2s.)
<b>Failure protection active power mode</b>	Specifies the active power output mode after the inverter or PCS detects that the communication with the SmartMGC is interrupted. You are advised to set this parameter to <b>Fixed value</b> . <ul style="list-style-type: none"> <li>• <b>Fixed value:</b> The active power is limited by a fixed power value.</li> <li>• <b>Percentage:</b> The active power is limited by a power percentage.</li> </ul>
<b>Active power limit when communication fails</b>	Specifies the fixed value or percentage of active power. You are advised to set this parameter to 0%.

**Step 6** After the parameters are set, click **Submit**.

----End

### 6.6.4.1.5 Remote Output Control

#### Description

Remote output control applies only to Japan. The SmartMGC obtains the time and dispatch information from the server of the power grid company, and delivers dispatch commands corresponding to the current time to the inverter to control its active power.

#### Procedure

**Step 1** Enable remote power scheduling for the inverter and PCS.

- Choose **Monitoring > ESS > Running Parameters** and set **Remote Scheduling** to **Enable**.
- Choose **Monitoring > Inverter > Running Parameters** and set **Remote Scheduling** to **Enable**.

**Step 2** Activate the active power control mode **Remote output control**.

1. Choose **Set > Grid Connection Control > Active Power**. The **Active power control mode** page is displayed.
2. Select **Remote output control** and click **OK**.  
If this option cannot be selected, deselect **Unlimited** and try again.

**Step 3** Synchronize the clock source of the server.

Choose **Set > Date and Time**, set **Clock source** to **NTP**, and enter the NTP server information.

**Step 4** Set **Remote output control** parameters.

**Table 6-110** Basic parameters

Parameter	Description
<b>Control area</b>	Set this parameter to the area where the remote output control function is used. In some areas, you need to import and enable the certificate to implement the remote output control function.
<b>Output control duration</b>	Set this parameter to the time required for the device to change its output power from 0% to 100% or from 100% to 0%.
<b>Plant ID</b>	Specifies the plant ID.
<b>Remote output control server</b>	Set this parameter to the IP address or domain name of the server. You can click <b>Server Connection Test</b> to test whether the server is connected.
<b>Certificate authentication</b>	Determine whether to import and enable a certificate based on the actual situation.
<b>Surplus power purchase</b>	<ul style="list-style-type: none"> <li>• <b>Disable:</b> The surplus power purchase function is disabled. The inverter output power is controlled by the SmartMGC according to the remote output control command issued by the power grid company. The output power of the PV array cannot exceed the active power dispatch value issued by the power grid company.</li> <li>• <b>Enable:</b> The surplus power purchase function is enabled. The inverter output power is controlled according to the remote output control command and the load power usage is tracked. <ul style="list-style-type: none"> <li>- When the load power is less than or equal to the remote output control value, the inverter output power is determined according to the remote output control command. The surplus inverter output power is fed into the power grid.</li> <li>- When the load power is greater than the remote output control value, the SmartMGC automatically adjusts the inverter output power to supply as much power as possible to loads. The inverter output power is used only by loads. The surplus power cannot be fed into the power grid.</li> </ul> </li> </ul>

Parameter	Description
<b>PV module capacity</b>	Set this parameter to the capacity of PV modules connected to the plant.
<b>Plant AC capacity</b>	Set this parameter to the AC capacity of the limited feed-in power from the plant.
<b>Latest connection status</b>	Displays the control information.
<b>Latest connection time</b>	
<b>Annual dispatch file last obtained at</b>	
<b>Current control in percentage</b>	

**Step 5** After the parameters are set, click **Submit**.

**Step 6** Click **Import** to import the output control file (in .data format) obtained from the website of the power grid company to the SmartMGC.

----End

## 6.6.4.2 Reactive Power

### Description

You can set the reactive power control mode of an array on the SmartMGC to ensure the stability and power quality of the power grid.

**Table 6-111** describes the reactive power control modes supported by the SmartMGC.

**Table 6-111** Reactive power control modes

Control Mode	Application Scenario	Overview
<b>No output</b>	This mode applies to the scenario where no reactive power adjustment is required at the grid connection point.	If an array is neither required to adjust the voltage at the grid connection point nor required to perform reactive power compensation, the devices can run with pure active power output.

Control Mode	Application Scenario	Overview
<b>Scheduling via DI</b>	This mode applies to the scenario where the grid DI controller needs to deliver reactive power adjustment commands.	This function applies only to some areas in Europe, such as Germany. According to the local standards, the grid dispatch signals need to be transmitted through an RCR over dry contact signals.  The SmartMGC receives RCR dispatch commands through the DI port and adjusts the reactive power output of the array according to the preset power factor.
<b>Fixed reactive power</b>	This mode applies to the scenario where an array is required to output constant reactive power at a fixed value at the specified time.	An array generates constant reactive power at the specified time and adjusts the reactive power according to the preset reactive power value in real time.
<b>Fixed power factor</b>	This mode applies to the scenario where an array is required to output constant reactive power at a specified power factor at the specified time.	An array generates constant reactive power at the specified time and adjusts the reactive power according to the preset power factor in real time.
<b>Remote scheduling</b>	This mode applies to the scenario where the northbound controller delivers a reactive power adjustment command through the SmartMGC.	The SmartMGC receives a dispatch command from the northbound controller through Modbus-TCP, GOOSE, or IEC 104, and adjusts the reactive power according to the command.
<b>Power factor closed-loop control</b>	This mode applies to the scenario where there is a certain requirement on the power factor at the grid connection point.	Power factor closed-loop control is a control mode in which the system monitors and adjusts the reactive power output in real time to ensure that the power factor is within the specified range. This mode applies to the scenario where the power factor at the grid connection point is limited. If the power factor does not reach the target, the system automatically performs dynamic reactive power compensation.

### 6.6.4.2.1 No Output

#### Description

If an array is neither required to adjust the voltage at the grid connection point nor required to perform reactive power compensation, the devices can run with pure active power output.

#### Procedure

- Step 1** Enable remote power scheduling for the inverter and PCS.
- Choose **Monitoring > ESS > Running Parameters** and set **Remote Scheduling** to **Enable**.
  - Choose **Monitoring > Inverter > Running Parameters** and set **Remote Scheduling** to **Enable**.
- Step 2** Activate the reactive power control mode **No output**.
1. Choose **Set > Grid Connection Control > Reactive Power**. The **Reactive power control mode** page is displayed.
  2. Select **No output** and click **OK**.

----End

### 6.6.4.2.2 Scheduling via DI

#### Description

This function applies only to some areas in Europe, such as Germany. According to the local standards, the grid dispatch signals need to be transmitted through an RCR over dry contact signals.

The SmartMGC receives RCR dispatch commands through the DI port and adjusts the reactive power output of the array according to the preset power factor.

The SmartMGC matches the preset DI1–DI4 dry contact signals (closed/open) based on the dry contact signals (closed/open) received by the DI1–DI4 ports, and adjusts the reactive power output of an array according to the preset power factor.

**Figure 6-18** RCR cable connection

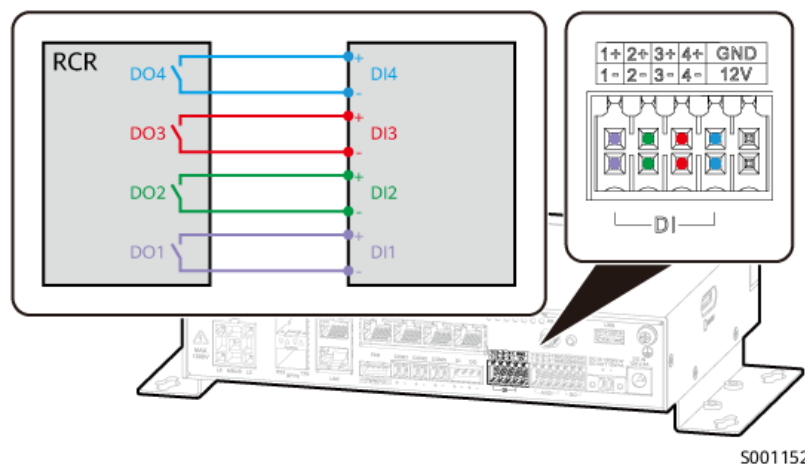

S001152

**NOTICE**

Ensure that the SmartMGC is properly connected to the RCR and the DI1–DI4 ports of the SmartMGC are not occupied by other services.

**Procedure**

- Step 1** Enable remote power scheduling for the inverter and PCS.
- Choose **Monitoring > ESS > Running Parameters** and set **Remote Scheduling** to **Enable**.
  - Choose **Monitoring > Inverter > Running Parameters** and set **Remote Scheduling** to **Enable**.
- Step 2** Activate the reactive power control mode **Scheduling via DI**.
- Choose **Set > Grid Connection Control > Reactive Power**. The **Reactive power control mode** page is displayed.
  - Select **Scheduling via DI** and click **OK**.
- Step 3** Set **Scheduling via DI** parameters.

**Figure 6-19** Scheduling via DI (example)

No.	DI1	DI2	DI3	DI4	Power Factor	Operation
1	Closed	Open	Closed	Open	0.900	 
2	Open	Open	Closed	Closed	1.000	 

**Table 6-112** Scheduling via DI

Parameter	Description
<b>DI1</b>	Set a DI signal combination according to the power grid company or RCR device description. The status combinations of DI1–DI4 must be unique.
<b>DI2</b>	
<b>DI3</b>	
<b>DI4</b>	
<b>Power Factor</b>	Specifies the power factor. <b>Figure 6-19</b> shows an example. <ul style="list-style-type: none"> <li>When the signals received by DI1–DI4 of the SmartMGC are "closed-open-closed-open," the array adjusts the reactive power output according to the power factor 0.9.</li> <li>When the signals received by DI1–DI4 of the SmartMGC are "open-open-closed-closed," the array adjusts the reactive power output according to the power factor 1.</li> </ul>

**Step 4** After the parameters are set, click **Submit**.

----End

### 6.6.4.2.3 Fixed Reactive Power

#### Description

An array generates constant reactive power at the specified time and adjusts the reactive power according to the preset reactive power value in real time.

#### Procedure

**Step 1** Enable remote power scheduling for the inverter and PCS.





- Choose **Monitoring > ESS > Running Parameters** and set **Remote Scheduling** to **Enable**.
- Choose **Monitoring > Inverter > Running Parameters** and set **Remote Scheduling** to **Enable**.

**Step 2** Activate the reactive power control mode **Fixed reactive power**.

1. Choose **Set > Grid Connection Control > Reactive Power**. The **Reactive power control mode** page is displayed.
2. Select **Fixed reactive power** and click **OK**.

**Step 3** Set **Fixed reactive power** parameters.

**Figure 6-20** Fixed reactive power (example)

No.	Start Time	Reactive Power (Kvar)	Operation
1	15:00:00	0.0	 
2	20:00:00	0.0	 

**Table 6-113** Fixed reactive power

Parameter	Description
<b>Start Time</b>	<p>Specifies the start time of control by fixed reactive power.</p> <p><b>Figure 6-20</b> shows an example.</p> <ul style="list-style-type: none"> <li>• The device runs according to the setting at 15:00:00 from 15:00:00 to 20:00:00 on the current day.</li> <li>• The device runs according to the setting at 20:00:00 from 20:00:00 to 00:00:00 (that is, 24:00:00) on the current day.</li> </ul> <p>If you want the device to follow the setting across days, you must specify the setting for 00:00:00.</p>
<b>Reactive Power</b>	<p>Specifies the reactive power. The reactive power range varies according to the connected device. After the device is connected, set this parameter based on the displayed value range.</p>

**Step 4** After the parameters are set, click **Submit**.

----End

#### 6.6.4.2.4 Fixed Power Factor

### Description

An array generates constant reactive power at the specified time and adjusts the reactive power according to the preset power factor in real time.

### Procedure

**Step 1** Enable remote power scheduling for the inverter and PCS.





- Choose **Monitoring > ESS > Running Parameters** and set **Remote Scheduling** to **Enable**.
- Choose **Monitoring > Inverter > Running Parameters** and set **Remote Scheduling** to **Enable**.

**Step 2** Activate the reactive power control mode **Fixed power factor**.

1. Choose **Set > Grid Connection Control > Reactive Power**. The **Reactive power control mode** page is displayed.
2. Select **Fixed power factor** and click **OK**.

**Step 3** Set **Fixed power factor** parameters.

**Figure 6-21** Fixed power factor (example)

No.	Start Time	Power Factor	Operation
1	15:00:00	0.900	 
2	20:00:00	0.800	 

**Table 6-114** Fixed power factor

Parameter	Description
<b>Start Time</b>	<p>Specifies the start time of control by fixed power factor. <a href="#">Figure 6-21</a> shows an example.</p> <ul style="list-style-type: none"> <li>• The device runs according to the setting at 08:00:00 from 08:00:00 to 20:00:00 on the current day.</li> <li>• The device runs according to the setting at 20:00:00 from 20:00:00 to 00:00:00 (that is, 24:00:00) on the current day.</li> </ul> <p>If you want the device to follow the setting across days, you must specify the setting for 00:00:00.</p>
<b>Power Factor</b>	Specifies the power factor.

**Step 4** After the parameters are set, click **Submit**.

----End

### 6.6.4.2.5 Remote Scheduling

#### Description

The SmartMGC receives a dispatch command from the northbound controller through Modbus-TCP, GOOSE, or IEC 104, and adjusts the reactive power according to the command.

#### NOTICE

After receiving a dispatch command from the northbound controller, the SmartMGC automatically activates the reactive power control mode **Remote Scheduling**.

#### Procedure

**Step 1** Enable remote power scheduling for the inverter and PCS.

- Choose **Monitoring > ESS > Running Parameters** and set **Remote Scheduling** to **Enable**.
- Choose **Monitoring > Inverter > Running Parameters** and set **Remote Scheduling** to **Enable**.

**Step 2** Activate the reactive power control mode **Remote Scheduling**.

1. Choose **Set > Grid Connection Control > Reactive Power**. The **Reactive power control mode** page is displayed.
2. Select **Remote Scheduling** and click **OK**.

**Step 3** (Optional) Set communication abnormality protection mechanisms.

When the communication between the SmartMGC and the northbound controller is abnormal, the following two mechanisms can be used to protect the devices:

- **Shut down upon reactive power signal timeout**

If remote dispatch commands between the SmartMGC and the northbound controller are interrupted, the SmartMGC shuts down the devices.

Parameter	Description
<b>Shut down upon reactive power signal timeout</b>	Enables or disables the function of shutdown upon reactive power signal timeout.

Parameter	Description
<b>Reactive power signal timeout threshold for shutdown</b>	Specifies the time for determining reactive power signal timeout. If the SmartMGC has not received remote dispatch commands for a period longer than the specified time, the system determines that the communication is abnormal and shuts down the devices.
<b>Start up upon recovery from reactive power signal timeout</b>	Enables or disables the function of automatic startup upon recovery from reactive power signal timeout. If this function is enabled, the system starts the devices when the reactive power signal timeout of the SmartMGC is rectified.

- **Limit reactive power upon communication timeout**

If remote dispatch commands between the SmartMGC and the northbound controller are interrupted, the SmartMGC derates the reactive power of devices.

Parameter	Description
<b>Limit reactive power upon communication timeout</b>	Enables or disables the function of limiting reactive power upon communication timeout.
<b>Communication timeout threshold for limiting reactive power</b>	Specifies the time for determining reactive power signal timeout. If the SmartMGC has not received remote dispatch commands for a period longer than the specified time, the system determines that the communication is abnormal and limits the power.
<b>PV reactive power upon communication timeout (Q/S)</b>	After the system determines that the communication is abnormal, the system limits the reactive power of inverters based on the parameter value.
<b>ESS reactive power upon communication timeout (Q/S)</b>	After the system determines that the communication is abnormal, the system limits the reactive power of PCSs based on the parameter value.

**Step 4** After the parameters are set, click **Submit**.

----End

### 6.6.4.2.6 Power Factor Closed-Loop Control

#### Description

Power factor closed-loop control is a control mode in which the system monitors and adjusts the reactive power output in real time to ensure that the power factor is within the specified range. This mode applies to the scenario where the power factor at the grid connection point is limited. If the power factor does not reach the target, the system automatically performs dynamic reactive power compensation.

Before enabling this function, ensure that the PT/CT sampling port is correctly connected to the PT/CT or ensure that the power meter is correctly connected to the SmartMGC. When adding a power meter, set **Meter usage** to **Feed-in meter**.

#### Procedure

- Step 1** Enable remote power scheduling for the inverter and PCS.
- Choose **Monitoring > ESS > Running Parameters** and set **Remote Scheduling** to **Enable**.
  - Choose **Monitoring > Inverter > Running Parameters** and set **Remote Scheduling** to **Enable**.
- Step 2** Activate the reactive power control mode **Power factor closed-loop control**.
1. Choose **Set > Grid Connection Control > Reactive Power**. The **Reactive power control mode** page is displayed.
  2. Select **Power factor closed-loop control** and click **OK**.
- Step 3** Set **Power factor closed-loop control** parameters.

**Table 6-115** Power factor closed-loop control

Parameter	Description
<b>Target power factor</b>	Specifies the target power factor at the grid connection point. The system monitors the actual power factor at the grid connection point in real time and compares the actual power factor with the target value. If the difference between them exceeds the adjustment deadband, the SmartMGC delivers the power factor to all inverters and PCSs based on the adjustment interval.
<b>Adjustment interval</b>	Specifies the interval at which the SmartMGC delivers power factor adjustment commands.
<b>Adjustment deadband<sup>[1]</sup></b>	Specifies the adjustment threshold of power factor closed-loop control. The system triggers power factor closed-loop control only when the detected power factor change exceeds the value.
<b>Reactive compensation delay</b>	Specifies the delay time for starting reactive power compensation.

Parameter	Description
	[1]: This parameter takes effect only when the power factor of the meter is greater than 0.9.

**Step 4** After the parameters are set, click **Submit**.

----End

### 6.6.4.2.7 Characteristic Curve

#### Q-U Characteristic Curve

In the Q-U characteristic curve control mode, the device dynamically adjusts the ratio Q/S of output reactive power to apparent power in accordance with the ratio U/Un (%) of the actual grid voltage to the rated grid voltage.

**Step 1** Enable remote power scheduling for the inverter and PCS.

- Choose **Monitoring > ESS > Running Parameters** and set **Remote Scheduling** to **Enable**.
- Choose **Monitoring > Inverter > Running Parameters** and set **Remote Scheduling** to **Enable**.

**Step 2** Activate the reactive power control mode **Characteristic Curve**.

1. Choose **Set > Grid Connection Control > Reactive Power**. The **Reactive power control mode** page is displayed.
2. Select **Characteristic Curve** and click **OK**.

**Step 3** Select **Q-U Characteristic Curve** and click **Submit**.

**Step 4** Set **Q-U Characteristic Curve** parameters.

**Table 6-116** Q-U characteristic curve

Parameter	Description
<b>Q-U characteristic curve mode</b>	Specifies the Q-U characteristic curve mode.
<b>Reactive power adjustment time</b>	Specifies the change interval of the reactive power at the grid connection point.
<b>Q-U scheduling triggering power percentage</b>	Under a specific grid code, the characteristic curve takes effect only when the actual output active power of the device is greater than the specified value.
<b>Q-U Scheduling Exit Power Percentage</b>	Under a specific grid code, the characteristic curve becomes invalid only when the actual output active power of the device is less than the specified value.
<b>Q-U characteristic curve minimum PF limit</b>	Limits the actual minimum PF when the Q-U characteristic curve takes effect.

Parameter	Description
<b>Q-U curve delay time</b>	Specifies the delay time for the Q-U characteristic curve to take effect.
<b>Q-U characteristic curve setting</b>	Set this parameter as required. When configuring the curve, ensure that the <b>U/Un</b> value of a point is greater than the <b>U/Un</b> value of the previous point.
<b>U/Un</b>	
<b>Q/S</b>	

**Step 5** After the parameters are set, click **Set**.

----End

## cosφ-P/Pn Characteristic Curve

In the cosφ-P/Pn characteristic curve control mode, the device dynamically adjusts the power factor cosφ in accordance with the P/Pn (%) based on the VDE-4105 and BDEW German standards.

**Step 1** Enable remote power scheduling for the inverter and PCS.

- Choose **Monitoring > ESS > Running Parameters** and set **Remote Scheduling** to **Enable**.
- Choose **Monitoring > Inverter > Running Parameters** and set **Remote Scheduling** to **Enable**.

**Step 2** Activate the reactive power control mode **Characteristic Curve**.

1. Choose **Set > Grid Connection Control > Reactive Power**. The **Reactive power control mode** page is displayed.
2. Select **Characteristic Curve** and click **OK**.

**Step 3** Select **cosφ-P/Pn characteristic curve** and click **Submit**.

**Step 4** Set **cosφ-P/Pn characteristic curve** parameters.

**Table 6-117** cosφ-P/Pn characteristic curve

Parameter	Description
<b>Reactive power adjustment time</b>	Time for the reactive power to reach the target value.
<b>cosφ-P/Pn trigger voltage</b>	Specifies the voltage for triggering the cosφ-P/Pn characteristic curve.
<b>cosφ-P/Pn exit voltage</b>	Specifies the voltage for exiting the cosφ-P/Pn characteristic curve.
<b>cosφ-P/Pn characteristic curve setting</b>	Set this parameter as required. When configuring the curve, ensure that the <b>P/Pn</b> value of a point is greater than the <b>P/Pn</b> value of the previous point.

Parameter	Description
P/Pn	
cosφ	

**Step 5** After the parameters are set, click **Set**.

----End

## PF-U Characteristic Curve

In the PF-U characteristic curve control mode, the device dynamically adjusts the PF at the device port based on the ratio  $U/U_n$  (%) of the actual grid voltage to the rated grid voltage.

**Step 1** Enable remote power scheduling for the inverter and PCS.

- Choose **Monitoring > ESS > Running Parameters** and set **Remote Scheduling** to **Enable**.
- Choose **Monitoring > Inverter > Running Parameters** and set **Remote Scheduling** to **Enable**.

**Step 2** Activate the reactive power control mode **Characteristic Curve**.

1. Choose **Set > Grid Connection Control > Reactive Power**. The **Reactive power control mode** page is displayed.
2. Select **Characteristic Curve** and click **OK**.

**Step 3** Select **PF-U characteristic curve** and click **Submit**.

**Step 4** Set **PF-U characteristic curve** parameters.

**Table 6-118** PF-U characteristic curve

Parameter	Description
PF-U characteristic curve setting	Set this parameter as required. When configuring the curve, ensure that the <b>U/U<sub>n</sub></b> value of a point is greater than the <b>U/U<sub>n</sub></b> value of the previous point.
U/U <sub>n</sub>	
French Polynesia	

**Step 5** After the parameters are set, click **Set**.

----End

## Q-P Characteristic Curve

In the Q-P characteristic curve control mode, the device adjusts the ratio  $Q/P_n$  of the output reactive power to the rated power based on the ratio  $P/P_n$  of the current active power to the rated power.

- Step 1** Enable remote power scheduling for the inverter and PCS.
- Choose **Monitoring > ESS > Running Parameters** and set **Remote Scheduling** to **Enable**.
  - Choose **Monitoring > Inverter > Running Parameters** and set **Remote Scheduling** to **Enable**.
- Step 2** Activate the reactive power control mode **Characteristic Curve**.
1. Choose **Set > Grid Connection Control > Reactive Power**. The **Reactive power control mode** page is displayed.
  2. Select **Characteristic Curve** and click **OK**.
- Step 3** Select **Q-P Characteristic Curve** and click **Submit**.
- Step 4** Set **Q-P Characteristic Curve** parameters.

**Table 6-119** Q-P characteristic curve

Parameter	Description
<b>Reactive power adjustment time</b>	Time for the reactive power to reach the target value.
<b>Q-P characteristic curve setting</b>	Set this parameter as required. When configuring the curve, ensure that the <b>P/Pn</b> value of a point is greater than the <b>P/Pn</b> value of the previous point.
<b>P/Pn</b>	
<b>Q/Pn</b>	

- Step 5** After the parameters are set, click **Set**.

----End

### 6.6.4.3 ESS Control

#### Description

ESS control allows the SmartMGC to control the power output of devices in an array according to different control modes, ensuring that the grid and loads work properly and maximizing the economic benefits of the plant.

**Table 6-120** describes the ESS control policies supported by the SmartMGC.

**Table 6-120** ESS control

Working Mode	Overview
<b>No control</b>	This mode is used only for deployment and commissioning. The SmartMGC does not control the ESS power.

Working Mode	Overview
<p><b>Max. self-consumption</b></p>	<p>This mode applies to PV+ESS systems in areas where the electricity price is high and the feed-in-tariff (FIT) subsidy is low or unavailable.</p> <p>PV power is preferentially supplied to loads, and the surplus PV power is used to charge the ESS. If the ESS is fully charged or being charged at full power, the surplus PV power is fed to the power grid. The grid cannot charge the ESS but can supply power to loads.</p>
<p><b>Charge/Discharge based on grid dispatch</b></p>	<p>This mode applies to the scenario where the northbound controller delivers active power dispatch commands.</p> <p>The purpose of discharge based on grid dispatch is to meet the active power dispatch target value at the grid connection point. PV energy is preferred. If the generated PV energy is insufficient, the ESS discharges energy and the energy is fed to the grid based on the active power dispatch target value. If the generated PV energy is sufficient, the energy is fed to the grid based on the active power dispatch target value, and the surplus PV energy is used to charge the ESS.</p> <p>The purpose of charge based on grid dispatch is to meet the active power dispatch target value at the grid connection point. If the battery charge power is insufficient or the PCS limits the power, the grid charges the batteries with the maximum capability. If the batteries are not fully charged when the scheduling target value is met, the PV power is used to charge the batteries.</p>
<p><b>TOU</b></p>	<p>This mode applies to PV+ESS or ESS-only systems in scenarios where the price difference is large between peak and off-peak hours and power meters are used.</p> <p>During off-peak hours, the grid supplies power to charge the ESS. During peak hours, the ESS discharges energy to loads.</p>
<p><b>TOU (fixed power)</b></p>	<p>This mode applies to ESS-only systems in scenarios where the price difference is large between peak and off-peak hours and no power meters are used.</p> <p>During off-peak hours, the grid supplies power to charge the ESS. During peak hours, the ESS discharges energy to loads.</p>

### 6.6.4.3.1 No Control

#### Description

This mode is used only for deployment and commissioning.

The SmartMGC does not control the ESS power.

## Procedure

**Step 1** Enable remote power dispatch for the PCS.

Choose **Monitoring > ESS > Running Parameters** and set **Remote Scheduling** to **Enable**.

**Step 2** Set **Working Mode** to **No control** for the ESS.

1. Choose **Set > Grid Connection Control > ESS Control > Control Mode**. The **Control Mode** page is displayed.
2. Select the **No control** mode and click **Submit**.

----End

### 6.6.4.3.2 Max. Self-Consumption

#### Description

This mode applies to PV+ESS systems in areas where the electricity price is high and the feed-in-tariff (FIT) subsidy is low or unavailable.

PV power is preferentially supplied to loads, and the surplus PV power is used to charge the ESS. If the ESS is fully charged or being charged at full power, the surplus PV power is fed to the power grid. The grid cannot charge the ESS but can supply power to loads.

Energy priority:

- PV energy supply priority: load > ESS > power grid
- Load power consumption priority: PV > ESS > power grid

The following uses [Figure 6-22](#) (ESS capacity: 800 kWh/400 kW) as an example.

Figure 6-22 Max. self-consumption

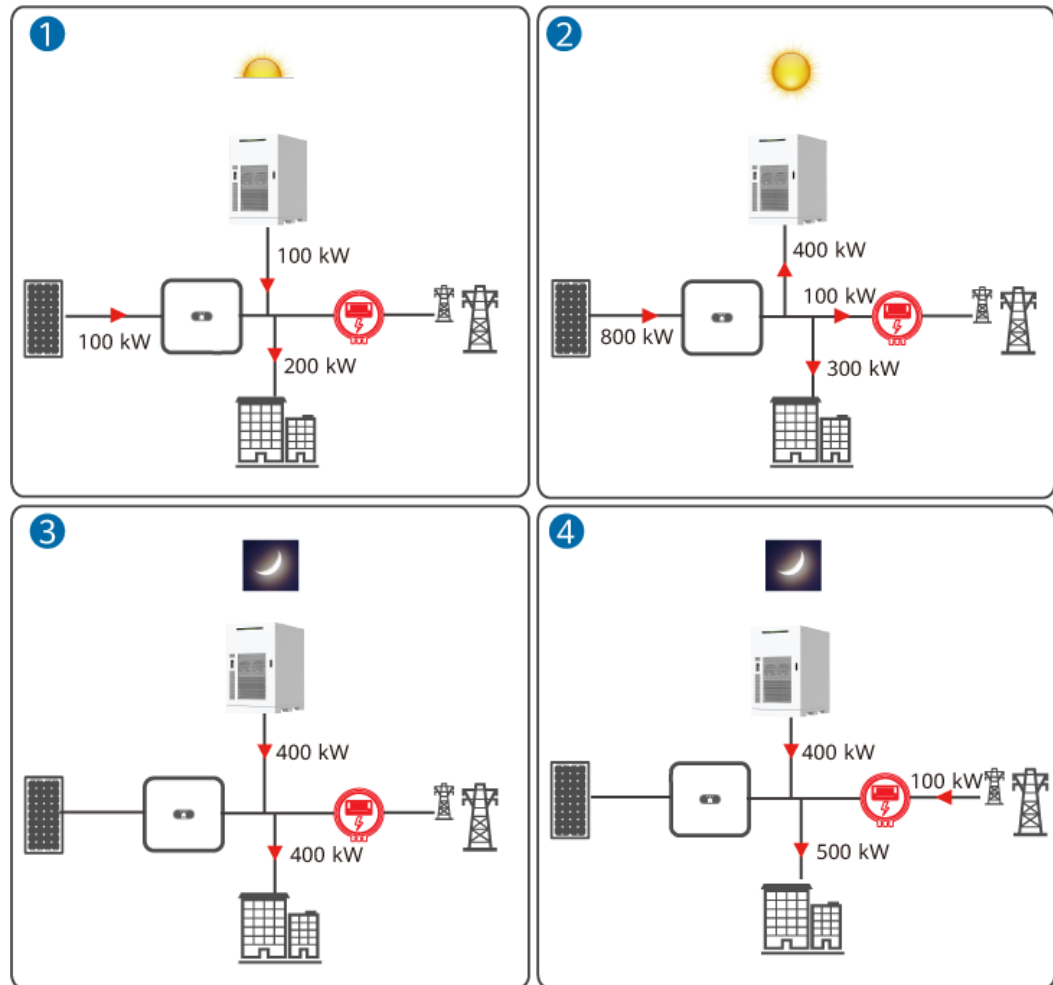

5001156

(1) 06:00–08:00: Insufficient irradiance

(2) 10:00–14:00: Sufficient irradiance

(3) 19:00–20:00: No irradiance

(4) 21:00–22:00: No irradiance

## Procedure

**Step 1** Enable remote power dispatch for the PCS.

Choose **Monitoring** > **ESS** > **Running Parameters** and set **Remote Scheduling** to **Enable**.

**Step 2** Set **Working Mode** to **Max. self-consumption** for the ESS.

1. Choose **Set** > **Grid Connection Control** > **ESS Control** > **Control Mode**. The **Control Mode** page is displayed.
2. Select the **Max. self-consumption** mode.

**Step 3** Set **Max. self-consumption** parameters.

**Table 6-121** Max. self-consumption

Parameter	Description
<p><b>Maximum grid power during battery discharge</b></p>	<p>The default value 0 W is recommended. Adjust the ESS discharge power based on the preset threshold in the ESS discharge scenario.</p> <ul style="list-style-type: none"> <li>• When the power purchased from the grid exceeds the preset threshold, the ESS starts discharging and adjusts the discharge power.</li> <li>• When the power purchased from the grid is less than or equal to the preset threshold, the ESS continues to execute the previous dispatch command.</li> </ul> <p>For example, if this parameter is set to 0.05 kW and the adjustment deadband is 0 W:</p> <ul style="list-style-type: none"> <li>• If the PV output power is 30 kW and the load power is 30 kW, no power is purchased from the grid and the ESS does not discharge energy.</li> <li>• If the PV output power is 30 kW and the load power is 30.04 kW, 0.04 kW power is purchased from the grid and the ESS discharges 0 kW of energy.</li> <li>• If the PV output power is 30 kW and the load power is 30.06 kW, 0.05 kW power is purchased from the grid and the ESS discharges 0.01 kW of energy.</li> </ul>
<p><b>Adjustment deadband</b></p>	<p>The default value 0 W is recommended. Set the precision of the ESS discharge power in the ESS discharge scenario.</p> <ul style="list-style-type: none"> <li>• If the actual power purchase threshold of the grid connection point is within the range, the ESS executes the previous dispatch command.</li> <li>• If the actual power purchase threshold of the grid connection point is not within the range, the ESS discharges energy.</li> </ul>

**Step 4** After the parameters are set, click **Submit**.

----End

### 6.6.4.3.3 Charge/Discharge Based on Grid Dispatch

#### Description

This mode applies to the scenario where the northbound controller delivers active power dispatch commands.

The purpose of discharge based on grid dispatch is to meet the active power dispatch target value at the grid connection point. PV energy is preferred. If the generated PV energy is insufficient, the ESS discharges energy and the energy is fed to the grid based on the active power dispatch target value. If the generated

PV energy is sufficient, the energy is fed to the grid based on the active power dispatch target value, and the surplus PV energy is used to charge the ESS.

The purpose of charge based on grid dispatch is to meet the active power dispatch target value at the grid connection point. If the battery charge power is insufficient or the PCS limits the power, the grid charges the batteries with the maximum capability. If the batteries are not fully charged when the scheduling target value is met, the PV power is used to charge the batteries.

In some countries, the grid is not allowed to charge the ESS. In this case, this mode cannot be used.

## Procedure

**Step 1** Enable remote power dispatch for the PCS.

Choose **Monitoring > ESS > Running Parameters** and set **Remote Scheduling to Enable**.

**Step 2** Set **Working Mode** to **Charge/Discharge based on grid dispatch** for the ESS.

1. Choose **Set > Grid Connection Control > ESS Control > Control Mode**. The **Control Mode** page is displayed.
2. Select the **Charge/Discharge based on grid dispatch** mode.

**Step 3** Set **Charge/Discharge based on grid dispatch** parameters.

**Table 6-122** Running parameters for charge/discharge based on grid dispatch

Parameter	Description
<b>Maximum grid power during battery discharge</b>	<p>The default value 0 W is recommended. Adjust the ESS discharge power based on the preset threshold in the ESS discharge scenario.</p> <ul style="list-style-type: none"> <li>• When the power purchased from the grid exceeds the preset threshold, the ESS starts discharging and adjusts the discharge power.</li> <li>• When the power purchased from the grid is less than or equal to the preset threshold, the ESS continues to execute the previous dispatch command.</li> </ul> <p>For example, if this parameter is set to 0.05 kW and the adjustment deadband is 0 W:</p> <ul style="list-style-type: none"> <li>• If the PV output power is 30 kW and the load power is 30 kW, no power is purchased from the grid and the ESS does not discharge energy.</li> <li>• If the PV output power is 30 kW and the load power is 30.04 kW, 0.04 kW power is purchased from the grid and the ESS discharges 0 kW of energy.</li> <li>• If the PV output power is 30 kW and the load power is 30.06 kW, 0.05 kW power is purchased from the grid and the ESS discharges 0.01 kW of energy.</li> </ul>

Parameter	Description
<b>Charge/Discharge time window control</b>	<p>This function applies only to PV+ESS collaborative control. You are advised to retain the default value <b>Disable</b>. After this function is enabled, you can set the time segments of non-charge, non-discharge, charge, and discharge.</p> <ul style="list-style-type: none"> <li>● PV+ESS array: In PV+ESS collaborative control, the target value configured for the ESS charge/discharge time window takes precedence over the scheduling command.</li> <li>● PV+ESS array: In PV+ESS independent control, the dispatch command takes precedence over the target value configured for the ESS charge and discharge time window.</li> <li>● ESS-only array: The dispatch command takes precedence over the target value configured for the ESS charge and discharge time window.</li> </ul>
<b>Start and End Time</b>	<p>Specifies the start time and end time of charge/discharge. A maximum of 14 time segments can be set. The time segments cannot overlap.</p> <ul style="list-style-type: none"> <li>● <b>Non-charge</b>: ESS charge is forbidden.</li> <li>● <b>Non-discharge</b>: ESS discharge is forbidden.</li> <li>● <b>Charge</b>: ESS charge is allowed.</li> <li>● <b>Discharge</b>: ESS discharge is allowed.</li> </ul>
<b>Charge/Discharge</b>	
<b>Charge/Discharge Power</b>	Specifies the ESS charge/discharge power.
<b>Interval</b>	Specifies the charge/discharge interval.

**Step 4** After the parameters are set, click **Submit**.

----End

#### 6.6.4.3.4 TOU

### Description

This mode applies to PV+ESS or ESS-only systems in scenarios where the price difference is large between peak and off-peak hours and power meters are used.

During off-peak hours, the grid supplies power to charge the ESS. During peak hours, the ESS discharges energy to loads.

In this mode, at least one charge or discharge period for the ESS needs to be set. For example, if you set the low electricity price period at night as the charge period, the system charges the ESS at the maximum power during this period. If you set the high electricity price period as the discharge period, the ESS discharges only according to the actual demand of load power. The ESS can discharge only during the discharge period, reducing electricity costs.

In some countries, the grid is not allowed to charge the ESS. In this case, this mode cannot be used.

The following uses [Figure 6-23](#) as an example (ESS capacity: 800 kWh/400 kW, **Max. self-consumption** enabled).

Figure 6-23 TOU

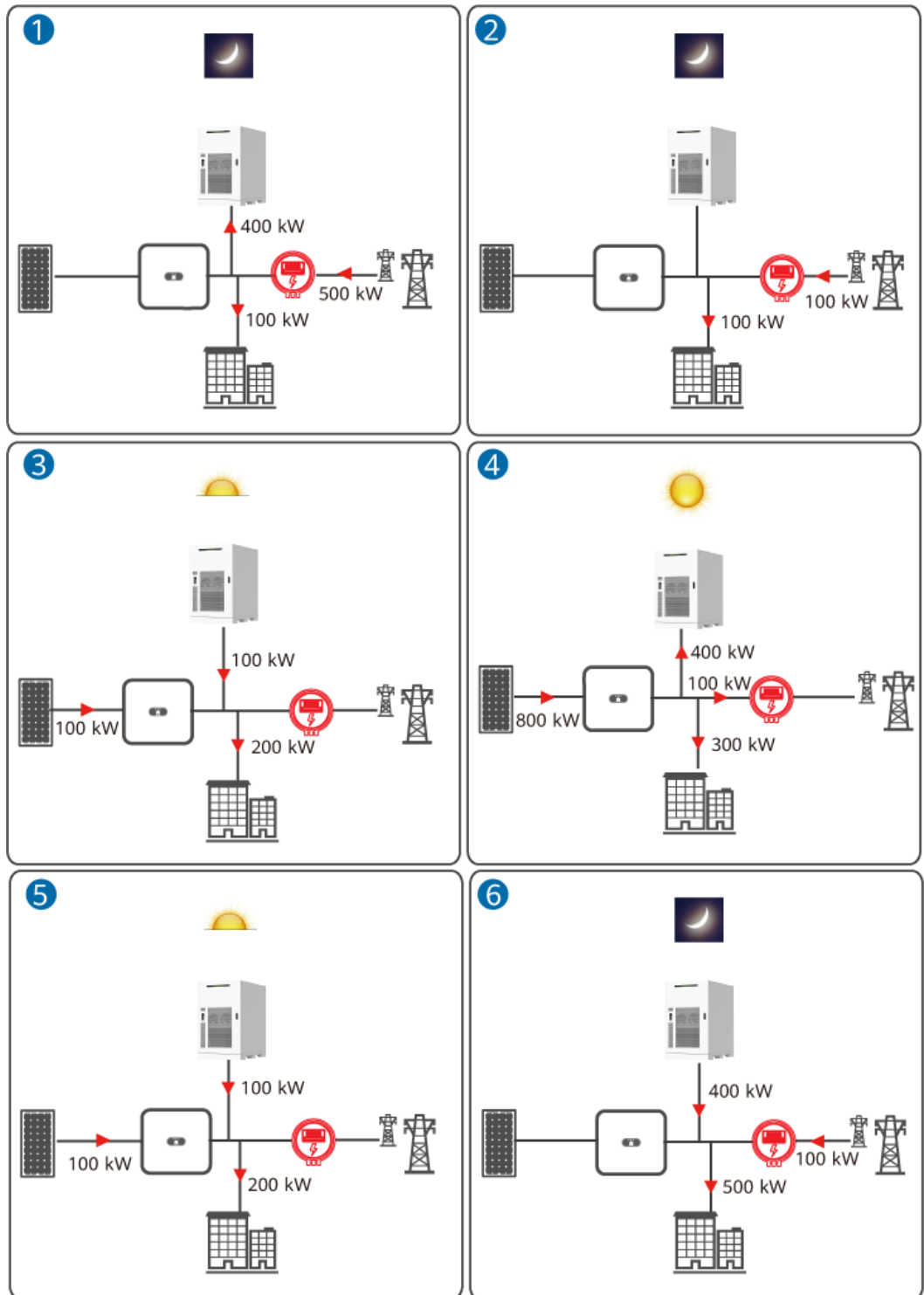

(1) 00:00–06:00: Charge period

(2) 00:00–06:00: Charge period

(3) 06:00–08:30: Insufficient irradiance during the discharge period

(4) 10:00–14:00: Sufficient irradiance during the discharge period

(5) 17:00–18:00: Insufficient irradiance during the discharge period

(6) 21:00–22:00: Discharge period

## Procedure

**Step 1** Enable remote power dispatch for the PCS.

Choose **Monitoring > ESS > Running Parameters** and set **Remote Scheduling** to **Enable**.

**Step 2** Set **Working Mode** to **TOU** for the ESS.

1. Choose **Set > Grid Connection Control > ESS Control > Control Mode**. The **Control Mode** page is displayed.
2. Select the **TOU** mode.

**Step 3** Set **TOU** parameters.

**Table 6-123** TOU

Parameter	Description
<b>Max. self-consumption</b>	<p>Set this parameter to <b>Enable</b> when both <b>TOU</b> and <b>Max. self-consumption</b> are chosen.</p> <ul style="list-style-type: none"> <li>• <b>Enable:</b> The maximum self-consumption function is enabled. When the PV power is greater than the load power, the surplus PV power is charged to the ESS. After the charge power reaches the maximum value or the ESS is fully charged, the surplus PV power is fed to the grid.</li> <li>• <b>Disable:</b> The maximum self-consumption function is disabled. When the PV power is greater than the load power, the surplus PV power is preferentially fed to the grid. After the feed-in power reaches the maximum value, the surplus PV power is charged to the ESS.</li> </ul>
<b>Maximum charge power from AC</b>	<p>Specifies the maximum power at which the grid charges the ESS. The value is determined by the local power grid company. If there is no requirement, the value is the maximum charge power of the ESS by default.</p> <p>If <b>Draw power from grid for off-grid power backup</b> (see <a href="#">Table 6-141</a>) is triggered, <b>Charge power for off-grid power backup</b> determines the grid power charged to the ESS. You are advised to set this parameter to the same value as <b>Charge power for off-grid power backup</b>.</p>

Parameter	Description
<b>Maximum grid power during battery discharge</b>	<p>The default value 0 W is recommended. Adjust the ESS discharge power based on the preset threshold in the ESS discharge scenario.</p> <ul style="list-style-type: none"> <li>• When the power purchased from the grid exceeds the preset threshold, the ESS starts discharging and adjusts the discharge power.</li> <li>• When the power purchased from the grid is less than or equal to the preset threshold, the ESS continues to execute the previous dispatch command.</li> </ul> <p>For example, if this parameter is set to 0.05 kW and the adjustment deadband is 0 W:</p> <ul style="list-style-type: none"> <li>• If the PV output power is 30 kW and the load power is 30 kW, no power is purchased from the grid and the ESS does not discharge energy.</li> <li>• If the PV output power is 30 kW and the load power is 30.04 kW, 0.04 kW power is purchased from the grid and the ESS discharges 0 kW of energy.</li> <li>• If the PV output power is 30 kW and the load power is 30.06 kW, 0.05 kW power is purchased from the grid and the ESS discharges 0.01 kW of energy.</li> </ul>
<b>Adjustment deadband</b>	<p>The default value 0 W is recommended. Set the precision of the ESS discharge power in the ESS discharge scenario.</p> <ul style="list-style-type: none"> <li>• If the actual power purchase threshold of the grid connection point is within the range, the ESS executes the previous dispatch command.</li> <li>• If the actual power purchase threshold of the grid connection point is not within the range, the ESS discharges energy.</li> </ul>
<b>Start and End Time</b>	<p>Specifies the start time and end time of charge/discharge. A maximum of 14 time segments can be set. The time segments cannot overlap.</p> <ul style="list-style-type: none"> <li>• <b>Discharge:</b> The ESS is allowed to discharge energy to loads, but cannot feed energy to the grid.</li> <li>• <b>Charge:</b> ESS charge is allowed.</li> </ul>
<b>Charge/Discharge</b>	
<b>Interval</b>	

**Step 4** After the parameters are set, click **Submit**.

----End

### 6.6.4.3.5 TOU (Fixed Power)

#### Description

This mode applies to ESS-only systems in scenarios where the price difference is large between peak and off-peak hours and no power meters are used.

During off-peak hours, the grid supplies power to charge the ESS. During peak hours, the ESS discharges energy to loads.

In this mode, at least one charge or discharge period for the ESS needs to be set. For example, if you set the low electricity price period at night as the charge period, the system charges the ESS at the fixed power during this period. If you set the high electricity price period as the discharge period, the ESS can discharge energy only during the discharge period at the fixed power, reducing electricity costs.

In some countries, the grid is not allowed to charge the ESS. In this case, this mode cannot be used.

#### Procedure

**Step 1** Enable remote power dispatch for the PCS.

Choose **Monitoring > ESS > Running Parameters** and set **Remote Scheduling** to **Enable**.

**Step 2** Set **Working Mode** to **Charge/Discharge based on grid dispatch** for the ESS.

1. Choose **Set > Grid Connection Control > ESS Control > Control Mode**. The **Control Mode** page is displayed.
2. Select the **TOU (fixed power)** mode.

**Step 3** Set **TOU (fixed power)** parameters.

**Table 6-124** TOU (fixed power)

Parameter	Description
<p><b>Maximum grid power during battery discharge</b></p>	<p>The default value 0 W is recommended. Adjust the ESS discharge power based on the preset threshold in the ESS discharge scenario.</p> <ul style="list-style-type: none"> <li>• When the power purchased from the grid exceeds the preset threshold, the ESS starts discharging and adjusts the discharge power.</li> <li>• When the power purchased from the grid is less than or equal to the preset threshold, the ESS continues to execute the previous dispatch command.</li> </ul> <p>For example, if this parameter is set to 0.05 kW and the adjustment deadband is 0 W:</p> <ul style="list-style-type: none"> <li>• If the PV output power is 30 kW and the load power is 30 kW, no power is purchased from the grid and the ESS does not discharge energy.</li> <li>• If the PV output power is 30 kW and the load power is 30.04 kW, 0.04 kW power is purchased from the grid and the ESS discharges 0 kW of energy.</li> <li>• If the PV output power is 30 kW and the load power is 30.06 kW, 0.05 kW power is purchased from the grid and the ESS discharges 0.01 kW of energy.</li> </ul>
<p><b>Adjustment deadband</b></p>	<p>The default value 0 W is recommended. Set the precision of the ESS discharge power in the ESS discharge scenario.</p> <ul style="list-style-type: none"> <li>• If the actual power purchase threshold of the grid connection point is within the range, the ESS executes the previous dispatch command.</li> <li>• If the actual power purchase threshold of the grid connection point is not within the range, the ESS discharges energy.</li> </ul>
<p><b>Start and End Time</b> <b>Charge/Discharge</b></p>	<p>Specifies the start time and end time of charge/discharge. A maximum of 14 time segments can be set. The time segments cannot overlap.</p> <ul style="list-style-type: none"> <li>• <b>Discharge:</b> <ul style="list-style-type: none"> <li>- In the scenario with a power meter, the ESS is allowed to discharge energy to loads, but cannot feed energy to the grid.</li> <li>- In the scenario without a power meter, the ESS is allowed to discharge energy to loads or feed energy to the grid.</li> </ul> </li> <li>• <b>Charge:</b> Charging the ESS with grid power is allowed.</li> </ul>

Parameter	Description
<b>Charge/Discharge Power</b>	Specifies the ESS charge/discharge power.
<b>Interval</b>	Specifies the charge/discharge interval.

**Step 4** After the parameters are set, click **Submit**.

----End

### 6.6.4.3.6 Automatic SOC/SOH Calibration

#### Description

Automatic SOC calibration improves SOC estimation accuracy and prevents inaccurate SOC readings for an ESS rack or cabinet.

Automatic SOH calibration improves SOH estimation accuracy and predicts the battery lifespan of an ESS rack or cabinet.

#### Procedure

**Step 1** Choose **Set > Grid Connection Control > ESS Control > Control Mode**. The **Control Mode** page is displayed.

**Step 2** Set parameters for automatic SOC/SOH calibration.

**Table 6-125** Power allocation

Parameter	Description
<b>Difference threshold for starting array SOC rapid balancing</b>	The default value 5% is recommended. Set this parameter as required. When the SOC difference between racks in an array is greater than the value of this parameter, the rapid balancing algorithm is started.

**Table 6-126** ESS parameters

Parameter	Description
<p><b>Automatic SOC calibration</b></p>	<p>During deployment and commissioning, set this parameter to <b>Disable</b>.</p> <p>After the automatic SOC calibration function is enabled, the ESS calibrates the SOC accuracy periodically by rack or cabinet. During the calibration, the end-of-charge SOC and end-of-discharge SOC settings will be overridden so that the ESS can be fully charged or discharged, and then the battery capacity is calculated.</p> <p>This function will cause SOC inconsistency between racks or cabinets, which is normal. Before using this function, contact technical support engineers to evaluate the impact of SOC inconsistency between racks or cabinets during automatic calibration on the ESS.</p>
<p><b>SOC auto calibration period</b></p>	<p>This parameter is displayed when <b>Automatic SOC calibration</b> is set to <b>Enable</b>.</p> <p>Set the automatic SOC calibration interval:</p> <ul style="list-style-type: none"> <li>• If the battery SOC stays in the range of 10% to 90% most of the time, for example, in the microgrid scenario, the recommended calibration interval is less than or equal to 30 days.</li> <li>• If the battery SOC stays in the range of 40% to 60% most of the time, for example, in the frequency regulation scenario, the recommended calibration interval is less than or equal to 180 days.</li> <li>• If the battery SOC stays below 10% or at 100% most of the time, for example, in the peak shaving scenario, the recommended calibration interval is less than or equal to 180 days.</li> </ul>

Parameter	Description
<b>Automatic SOH calibration</b>	<p>During deployment and commissioning, set this parameter to <b>Disable</b>.</p> <p>After the automatic SOH calibration function is enabled, the ESS calibrates the SOH accuracy periodically by rack or cabinet. During the calibration, the end-of-charge SOC and end-of-discharge SOC settings will be overridden so that the ESS can be fully charged or discharged, and then the battery capacity is calculated. The charge and discharge response will be affected during the calibration. Suggestion: During SOH calibration, after the system is fully charged, maintain the charge command for 30 to 60 minutes. After the discharge is complete, maintain the discharge command for 30 to 60 minutes.</p> <p>This function will cause SOC inconsistency between racks or cabinets, which is normal. Before using this function, contact technical support engineers to evaluate the impact of SOC inconsistency between racks or cabinets during automatic calibration on the ESS.</p>

**Step 3** After the parameters are set, click **Submit**.

----End

### 6.6.4.3.7 Scheduling Mode

#### Description

The scheduling mode is used only in scenarios where ESSs with different C-rates are used. Power can be allocated based on different scheduling modes.

The scheduling modes include **Energy first** and **Power first**.

#### Procedure

**Step 1** Choose **Set > Grid Connection Control > ESS Control > Control Mode**. The **Control Mode** page is displayed.

**Step 2** Select **Scheduling mode**.

**Table 6-127** Scheduling mode

Parameter	Description
<b>Scheduling mode</b>	<ul style="list-style-type: none"> <li> <b>Energy first:</b> If ESSs with different C-rates are used together in C&amp;I scenarios, the power is allocated based on the minimum C-rate of all ESSs in the array.                      If LUNA2000-107-1S11 (C-rate: 1C) and LUNA2000-215-2S10 (C-rate: 0.5C) are used together, the charge/discharge power of the array does not exceed 162 kW.                 </li> <li> <b>Power first:</b> If ESSs with different C-rates are used together in C&amp;I scenarios, the power is allocated based on the C-rate of each ESS.                      If LUNA2000-107-1S11 (C-rate: 1C) and LUNA2000-215-2S10 (C-rate: 0.5C) are used together, the charge/discharge power of the array does not exceed 216 kW, the power of LUNA2000-107KWH-1H1 may be completely discharged first, and the charge/discharge power of the array may decrease. In addition, the system might collapse in off-grid operation.                 </li> </ul>

**Step 3** After the parameters are set, click **Submit**.

----End

#### 6.6.4.3.8 ESS SOC

### Description

Adjusting the SOC of an ESS helps the system flexibly cope with load fluctuations (such as peak energy consumption) or grid dispatch commands (such as demand response), facilitating efficient energy allocation and utilization.

### Procedure

**Step 1** Choose **Set > Grid Connection Control > ESS Control > ESS SOC**. The **ESS SOC** page is displayed.

**Step 2** Set the ESS SOC.

**Table 6-128** ESS SOC

Parameter	Description
<b>Array end-of-charge SOC</b>	Specifies the array end-of-charge SOC. When the SOC of the ESS reaches the preset value, the ESS stops charging.

Parameter	Description
<b>Array end-of-discharge SOC</b>	Specifies the array end-of-discharge SOC. When the SOC of the ESS reaches the preset value, the ESS stops discharging.
<b>Min. SOC for off-grid power backup</b>	The reserved power, which is used only in off-grid scenarios, ensure that the off-grid system can run for a certain period of time.
<b>Backup power SOC for capacity/demand control</b>	The reserved power, which is used for capacity/demand control, ensures that the ESS can meet capacity/demand control requirements. The value of this parameter affects the peak shaving capability. A larger value indicates a stronger peak shaving capability.
<b>Max. SOC for charging on/off-grid ESS</b>	This parameter is displayed when <b>Scenario</b> is set to <b>On/Off-grid</b> . <ul style="list-style-type: none"> <li>Seamed switching scenario: maximum SOC for charging the ESS in off-grid mode</li> <li>Seamless switching scenario: maximum SOC for charging the ESS in on-grid or off-grid mode</li> </ul>
<b>Min. SOC for discharging on/off-grid ESS</b>	This parameter is displayed when <b>Scenario</b> is set to <b>On/Off-grid</b> . <ul style="list-style-type: none"> <li>Seamed switching scenario: minimum SOC for discharging the ESS in off-grid mode</li> <li>Seamless switching scenario: minimum SOC for discharging the ESS in on-grid or off-grid mode</li> </ul>
<b>Max. SOC for charging off-grid ESS</b>	Specifies the maximum SOC for charge in off-grid state.
<b>Min. SOC for discharging off-grid ESS</b>	Specifies the minimum SOC for discharge in off-grid state.
<b>SOC for turning on critical load switch</b>	This parameter is displayed when <b>Scenario</b> is set to <b>Off-grid</b> and the critical load switch is connected. When the array SOC is greater than or equal to the value, the critical load switch is turned on. <b>SOC for turning on critical load switch &gt; SOC for turning off critical load switch</b>
<b>SOC for turning off critical load switch</b>	This parameter is displayed when <b>Scenario</b> is set to <b>Off-grid</b> and the critical load switch is connected. When the array SOC is less than or equal to the value, the critical load switch is turned off. <b>SOC for turning on critical load switch &gt; SOC for turning off critical load switch</b>

Parameter	Description
<b>SOC for turning on minor load switch</b>	This parameter is displayed when <b>Scenario</b> is set to <b>Off-grid</b> and the minor load switch is connected. When the array SOC is greater than or equal to the value, the minor load switch is turned on. <b>SOC for turning on minor load switch &gt; SOC for turning off minor load switch</b>
<b>SOC for turning off minor load switch</b>	This parameter is displayed when <b>Scenario</b> is set to <b>Off-grid</b> and the minor load switch is connected. When the array SOC is less than or equal to the value, the minor load switch is turned off. <b>SOC for turning on minor load switch &gt; SOC for turning off minor load switch</b>
<b>SOC for turning on common load switch</b>	This parameter is displayed when <b>Scenario</b> is set to <b>Off-grid</b> and the common load switch is connected. When the array SOC is greater than or equal to the value, the common load switch is turned on. <b>SOC for turning on common load switch &gt; SOC for turning off common load switch</b>
<b>SOC for turning off common load switch</b>	This parameter is displayed when <b>Scenario</b> is set to <b>Off-grid</b> and the common load switch is connected. When the array SOC is less than or equal to the value, the common load switch is turned off. <b>SOC for turning on common load switch &gt; SOC for turning off common load switch</b>

 NOTE

- On/Off-grid scenario: **Array end-of-discharge SOC < Min. SOC for discharging on/off-grid ESS < Min. SOC for off-grid power backup < Backup power SOC for capacity/demand control < Max. SOC for charging on/off-grid ESS < Array end-of-charge SOC**
- Off-grid scenario: **Array end-of-discharge SOC < Min. SOC for discharging off-grid ESS < SOC for turning on/off load switch < Max. SOC for charging off-grid ESS < Array end-of-charge SOC**
- **SOC for turning on critical load switch < SOC for turning on minor load switch < SOC for turning on common load switch**
- **SOC for turning off critical load switch < SOC for turning off minor load switch < SOC for turning off common load switch**

**Step 3** After the parameters are set, click **Submit**.

----End

### 6.6.4.4 Capacity/Demand Control

### 6.6.4.4.1 Capacity Limit

#### Description

Capacity limit controls the maximum peak current at the grid connection point. If the capacity of the transformer or switch at the grid connection point is limited, this function ensures that the electric current purchased from or sold to the grid does not exceed the maximum peak current at the grid connection point.

---

**CAUTION**

When the capacity at the grid connection point exceeds the threshold, it takes 5s for the SmartMGC to control the capacity within the threshold. Check the overload performance of devices such as fuses and transformers onsite. If the overload performance does not meet the requirement, the system circuit breaker may trip.

---

**NOTICE**

- The capacity limit function is invalid when the SmartMGC and ESS are being updated.
- The overload capability of transformers, power distribution switches, and cables must be greater than the sum of the maximum charge current and maximum load current of the ESS.
- If the capacity limit is met 24 hours a day, the ratio of the ESS capacity to the load power must be properly set to ensure that the ESS has sufficient capacity to meet the capacity limit.
- When the capacity limit function is enabled in **TOU** mode, the charge/discharge time set in **TOU** mode must cover 24 hours of a day. Capacity limit is not supported in non-charge/discharge time.

#### Procedure

**Step 1** Enable the **Capacity limit** function.

1. Choose **Set > Grid Connection Control > Capacity/Demand Control**. The **Capacity/Demand Control** page is displayed.
2. Set **Capacity limit** to **Current limit**.

**Step 2** Set **Capacity limit** parameters.

**Table 6-129** Capacity limit

Parameter	Description
<b>Maximum feed-in current</b>	Set this parameter based on the maximum peak current in the feed-in direction of the grid connection point.

Parameter	Description
<b>Maximum current from grid</b>	Set this parameter based on the maximum peak current in the power purchase direction of the grid connection point.
<b>Shut down if feed-in current exceeds threshold</b>	<ul style="list-style-type: none"> <li>• <b>Enable:</b> The array will be forcibly shut down for 4 hours if the feed-in current exceeds the threshold. It is recommended that you use this function under the UK G100 regulations and configure relevant inverter/PCS parameters by referring to <a href="#">Step 3</a>. If the array shuts down due to this function, you need to manually start them after waiting for at least 4 hours.</li> <li>• <b>Disable:</b> The array will not shut down if the feed-in current exceeds the threshold.</li> </ul>
<b>Backup power SOC for capacity/demand control</b>	The reserved power, which is used for capacity/demand control, ensures that the ESS can meet capacity/demand control requirements. The value of this parameter affects the peak shaving capability. A larger value indicates a stronger peak shaving capability.

**Step 3** (Optional) Set inverter or PCS parameters.

**Inverter/PCS Parameters** needs to be set only under the UK G100 regulations. If not involved, skip this step.

**Table 6-130** Inverter or PCS parameters

Parameter	Description
<b>Active power change gradient</b>	To ensure that the power can be quickly adjusted to the target in the feed-in control scenario, you need to set this parameter. You are advised to set this parameter to 1000%/s.
<b>Soft start time</b>	Specifies the duration for the inverter or PCS output power to gradually increase when the device starts. The inverter or PCS output power increases slowly, reducing the feed-in risk. You are advised to set this parameter to 20s.
<b>Power-on soft start time due to power grid faults</b>	Specifies the duration for the inverter or PCS output power to gradually increase when the inverter or PCS starts after the grid fault is rectified. The inverter or PCS output power increases slowly, reducing the feed-in risk. You are advised to set this parameter to 20s.

Parameter	Description
<b>Protection upon Communication Failure</b>	In the feed-in control scenario, the inverter or PCS automatically reduces the power to prevent feed-in when the inverter or PCS is disconnected from the SmartMGC. <ul style="list-style-type: none"> <li>• <b>Enable:</b> The inverter or PCS automatically reduces the power to prevent feed-in when it is disconnected from the SmartMGC.</li> <li>• <b>Disable:</b> Protection upon communication failure is disabled.</li> </ul>
<b>Communication disconnection duration</b>	This parameter is displayed when <b>Protection upon Communication Failure</b> is set to <b>Enable</b> . If communication between the inverter or PCS and the SmartMGC is interrupted beyond the duration specified by this parameter, it is considered as a failure. You are advised to set this parameter to 3s. (For the RD1699 grid code of Spain, you are advised to set this parameter to 2s.)
<b>Failure protection active power mode</b>	Specifies the active power output mode after the inverter or PCS detects that the communication with the SmartMGC is interrupted. You are advised to set this parameter to <b>Fixed value</b> . <ul style="list-style-type: none"> <li>• <b>Fixed value:</b> The active power is limited by a fixed power value.</li> <li>• <b>Percentage:</b> The active power is limited by a power percentage.</li> </ul>
<b>Active power limit when communication fails</b>	Specifies the fixed value or percentage of active power. You are advised to set this parameter to 0%.

**Step 4** After the parameters are set, click **Submit**.

----End

#### 6.6.4.4.2 Demand Limit

##### Description

Demand limit controls the maximum peak power at the grid connection point. In some areas, electricity fees depend on both electricity usage and peak power. Demand limit applies to areas where peak demand charges are collected. It allows you to lower the peak power purchased from the grid during peak hours, thereby reducing electricity fees.

The demand limit function allows you to lower the peak power purchased from the grid only in **Max. self-consumption** or **TOU** mode during peak hours, reducing electricity fees.

**NOTICE**

The demand limit function is invalid when the SmartMGC and ESS are being updated.

**Procedure**

**Step 1** Enable the **Demand limit** function.

1. Choose **Set > Grid Connection Control > Capacity/Demand Control**. The **Capacity/Demand Control** page is displayed.
2. Set **Capacity limit** to **Active power limit** or **Apparent power limit**.
  - **Active power limit**: The active power purchased from the grid cannot exceed the limit.
  - **Apparent power limit**: The apparent power purchased from the grid cannot exceed the limit.

**Step 2** Set **Demand limit** parameters.

**Table 6-131** Demand limit

Parameter	Description
<b>Backup power SOC for capacity/demand control</b>	The reserved power, which is used for capacity/demand control, ensures that the ESS can meet capacity/demand control requirements. The value of this parameter affects the peak shaving capability. A larger value indicates a stronger peak shaving capability.
<b>Start and End Time</b>	Specifies the maximum peak power of the grid connection point in different time segments. A maximum of 14 time segments can be set for the maximum peak power. The time segments cannot overlap. The peak power is configured based on electricity prices in different time segments. You are advised to set the peak power to a low value when the electricity price is high.
<b>Maximum Peak Power</b>	
<b>Repeat</b>	Specifies the repeat execution time for configuration items.

**Step 3** After the parameters are set, click **Submit**.

----End

**6.6.4.5 Protection at Grid Connection Point**

**6.6.4.5.1 Protection Upon Power Exception at Grid Connection Point**

**Description**

If the PT/CT sampling port or the feed-in meter is abnormal and the output power at the grid connection point cannot be detected, the output power of PV inverters

and PCSs is limited to prevent the output power from exceeding the grid requirements.

Before enabling this function, ensure that the PT/CT sampling port is correctly connected to the PT/CT or ensure that the power meter is correctly connected to the SmartMGC. When adding a power meter, set **Meter usage** to **Feed-in meter**.

## Procedure

**Step 1** Choose **Set > Grid Connection Control > Protection at Grid Connection Point**. The **Protection at Grid Connection Point** page is displayed.

**Step 2** Set **Protection Upon Power Exception at Grid Connection Point** parameters.

**Table 6-132** Protection upon power exception at grid connection point

Parameter	Description
<b>PV power limit</b>	Specifies the active power limit of the inverter when the PT/CT sampling port or feed-in meter at the grid connection point is abnormal. You can manually change the active power percentage of the inverter as required.
<b>PCS power limit</b>	Specifies the active power limit of the PCS when the PT/CT sampling port or feed-in meter at the grid connection point is abnormal. You can manually change the active power percentage of the PCS as required.

**Step 3** After the parameters are set, click **Submit**.

----End

### 6.6.4.5.2 Shutdown at High Feed-In Power

## Description

In some areas, when the output power of inverters exceeds the specified range, the system is required to shut down all inverters. This function applies only to PV-only scenarios.

Before enabling this function, ensure that the PT/CT sampling port is correctly connected to the PT/CT or ensure that the power meter is correctly connected to the SmartMGC. When adding a power meter, set **Meter usage** to **Feed-in meter**.

## Procedure

**Step 1** Enable the **Shutdown at High Feed-in Power** function.

1. Choose **Set > Grid Connection Control > Protection at Grid Connection Point**. The **Protection at Grid Connection Point** page is displayed.
2. Set **Shutdown at High Feed-in Power** to **Enable**.

**Step 2** Set **Shutdown at High Feed-in Power** parameters.

**Table 6-133** Shutdown at high feed-in power

Parameter	Description
<b>Upper feed-in power threshold for shutdown</b>	After this function is enabled, the SmartMGC shuts down all inverters when the output power of the array exceeds the value of this parameter.
<b>High feed-in power duration threshold for triggering shutdown</b>	Specifies the duration from the time when the system detects that the output power exceeds the preset upper feed-in power threshold for shutdown to the time when the system shuts down inverters.

**Step 3** After the parameters are set, click **Submit**.

----End

### 6.6.4.6 DRM

#### Description

The demand response modes (DRM) apply only to Australia. According to Australian standards, inverters must obtain the DRM certification and enable the DRM function. The SmartMGC connects to a dry contact device. The power grid detects current changes through the AI port to control inverter startup and shutdown, and delivers power dispatch commands to the SmartMGC through the DI port to control the inverters.

**Figure 6-24** DRM cable connection

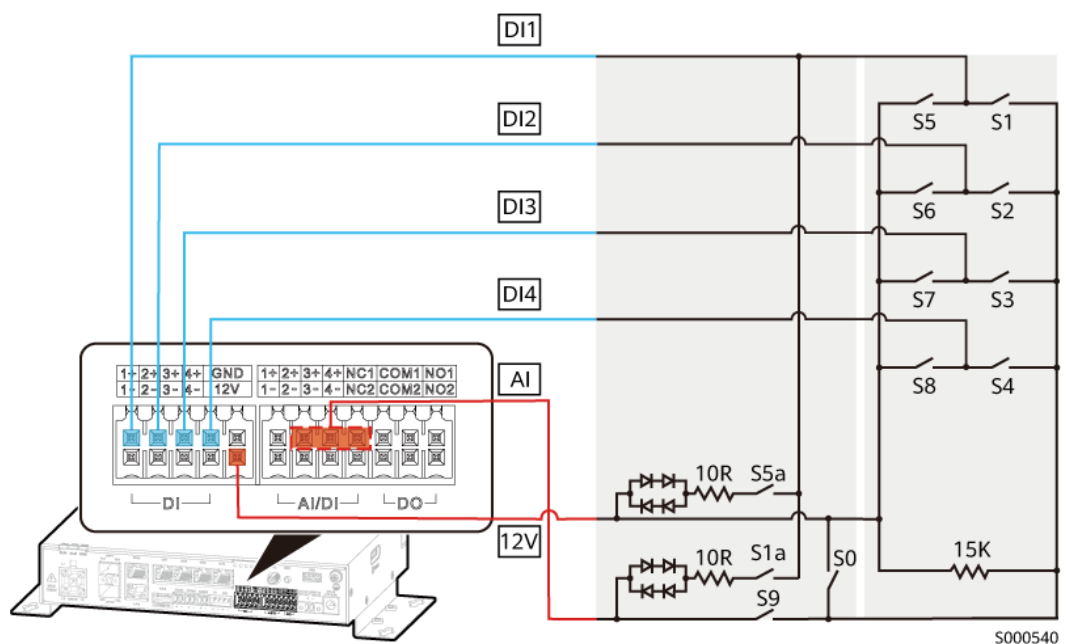

## Procedure

**Step 1** Set the port connected for DRM0 to the AI mode.

1. Choose **Set > Port Settings > AI/DI**. The AI/DI port setting page is displayed.
2. Set the port connected for DRM0 to **AI**.

**Step 2** Set **DRM** parameters.

1. Choose **Set > Grid Connection Control > DRM**. The **DRM** page is displayed.
2. Set **DRM0** parameters.

Parameter	Description
<b>Connected port</b>	Set the AI port for DRM0 signal input, that is, the port set in <a href="#">Step 1</a> .
<b>Startup current range</b>	When the current detected by the AI port is within the preset range, the inverter automatically starts. When the current detected is not within the preset range, the inverter automatically shuts down.

3. Set DRM power control parameters.

If DRM power dispatch is required, set the power control parameters. If not, you can ignore the power control parameters.





Before setting DRM power control parameters, choose **Set > Grid Connection Control > Active Power** and check whether the active power control mode is **Unlimited**. If not, set it to **Unlimited**.

### NOTICE

Only if the DRM0 mode is set, the active power control mode can be set to any mode.

SmartMGC matches the preset DI1–DI4 dry contact signals (closed/open) based on the dry contact signals (closed/open) received by the DI1–DI4 ports, and adjusts the power according to the preset percentage for active power limit and the power factor for reactive power limit.

**Figure 6-25** DRM power control (example)

No.	DRM5(DI1)	DRM6(DI2)	DRM7(DI3)	DRM8(DI4)	Percentage(%)	Q/S	Operation
1	Open	Closed	Open	Open	80	0.300	 
2	Closed	Open	Open	Open	90	0.500	 

**Table 6-134** Power control

Parameter	Description
DRM5(DI1)	Set the signal status of DI ports, the percentage for active power limit, and the power factor for reactive power limit according to the power grid company or DRM dry contact device description. The status combinations of DRM5 (DI1)–DRM8 (DI4) must be unique.
DRM6(DI2)	
DRM7(DI3)	
DRM8(DI4)	
Percentage	Set the percentage for active power limit and the power factor for reactive power limit. <b>Figure 6-25</b> shows an example.
Q/S	
	<ul style="list-style-type: none"> <li>– When the DI1–DI4 ports of the SmartMGC receive signals indicating that DI2 is closed and DI1, DI2, and DI4 are open, the inverter outputs active power equivalent to 80% of the rated active power and reactive power at a power factor of 0.3.</li> <li>– When the DI1–DI4 ports of the SmartMGC receive signals indicating that DI1 is closed and DI2, DI3, and DI4 are open, the inverter outputs active power equivalent to 90% of the rated active power and reactive power at a power factor of 0.5.</li> </ul>

**Step 3** After the parameters are set, click **Submit**.

----End

## 6.6.5 Microgrid Control

### 6.6.5.1 General Basic Settings

 NOTE

Path: **Set > Microgrid Control > General Basic Settings**

#### On/Off-Grid

**Table 6-135** Microgrid settings

Parameter	Description
MGCC mode	The value is displayed as <b>Enable</b> . You can choose <b>Monitoring &gt; Logger &gt; Running Parameters &gt; Scenario</b> to set the parameter.

Parameter	Description
<b>Automatic on/off-grid switching mode</b>	<ul style="list-style-type: none"> <li>• <b>Not controlled:</b> The system does not perform any operation. The user manually controls on/off-grid switching.</li> <li>• <b>Seamed switching:</b> The system automatically switches off the circuit breaker at the grid connection point and performs the corresponding sequence control process. This switching mode usually takes a certain period of time and may result in a short-time power supply interruption.</li> <li>• <b>Seamless switching:</b> The system can quickly complete the on/off-grid switching without causing a power supply interruption. If rapid on/off-grid switching is required, set <b>Status of rapid power loss detection</b><sup>[1]</sup> to <b>Enable</b>.</li> </ul>
<b>Seamed on/off-grid switching mode</b>	This parameter is displayed when <b>Automatic on/off-grid switching mode</b> is set to <b>Seamed switching</b> . Set this parameter to <b>Automatic</b> or <b>Manual</b> .
[1]: You can choose <b>Set &gt; Microgrid Control &gt; Advanced Control Configuration &gt; On/Off-Grid Switching Configuration</b> to set this parameter.	

**Table 6-136** Connection settings

Parameter	Description
<b>DI port status if on/off-grid switch is off</b>	<ul style="list-style-type: none"> <li>• Check the actual status of the grid connection point switch and the status received by DI4 (HV) (which can be viewed in <b>Overview &gt; Sampling Info</b>). <ul style="list-style-type: none"> <li>– If the actual status of the switch is Off and the port status is <b>Open</b> in <b>Overview &gt; Sampling Info</b>, set this parameter to <b>Open</b>.</li> <li>– If the actual status of the switch is Off and the port status is <b>Closed</b> in <b>Overview &gt; Sampling Info</b>, set this parameter to <b>Closed</b>.</li> </ul> </li> <li>• System cable connections: <ul style="list-style-type: none"> <li>– DI4 (HV): reports the Off state of the switch at the grid connection point.</li> <li>– DO7 (HV): turns on the switch at the grid connection point.</li> <li>– DO8 (HV): turns off the switch at the grid connection point (fast port); needs to connect to the DC power supply.</li> <li>– DO4 (HV): turns off the switch at the grid connection point (common port); supports the DC or AC power supply.</li> </ul> </li> </ul>

Parameter	Description
<b>Generator set control</b>	This parameter is displayed when <b>Automatic on/off-grid switching mode</b> is set to <b>Seamless switching</b> . It specifies whether to set <b>Generator set control</b> to <b>Enable</b> .
<b>Generator Set Control Method</b>	<ul style="list-style-type: none"> <li>• This parameter is displayed when <b>Generator set control</b> is set to <b>Enable</b>.</li> <li>• Pulse control mode: <ul style="list-style-type: none"> <li>– DO5 (HV): starts the genset.</li> <li>– DO6 (HV): shuts down the genset.</li> </ul> </li> <li>• Level control mode: <ul style="list-style-type: none"> <li>– DO5 (HV): starts the genset at high level when closed.</li> <li>– DO6 (HV): starts the genset at low level when open.</li> </ul> </li> </ul>
<b>Valid if grid-side switch is off</b>	<ul style="list-style-type: none"> <li>• This parameter is displayed when <b>Generator set control</b> is set to <b>Enable</b>.</li> <li>• Check the actual status of the grid switch and the status received by DI1 (HV) (which can be viewed in <b>Overview &gt; Sampling Info</b>). <ul style="list-style-type: none"> <li>– If the actual status of the switch is Off and the port status is <b>Open</b> in <b>Overview &gt; Sampling Info</b>, set this parameter to <b>Open</b>.</li> <li>– If the actual status of the switch is Off and the port status is <b>Closed</b> in <b>Overview &gt; Sampling Info</b>, set this parameter to <b>Closed</b>.</li> </ul> </li> <li>• System cable connection (grid switch Off state feedback): DI1 (HV)</li> </ul>
<b>Valid if genset-side switch is off</b>	<ul style="list-style-type: none"> <li>• This parameter is displayed when <b>Generator set control</b> is set to <b>Enable</b>.</li> <li>• Check the actual status of the genset switch and the status received by DI2 (HV) (which can be viewed in <b>Overview &gt; Sampling Info</b>). <ul style="list-style-type: none"> <li>– If the actual status of the switch is Off and the port status is <b>Open</b> in <b>Overview &gt; Sampling Info</b>, set this parameter to <b>Open</b>.</li> <li>– If the actual status of the switch is Off and the port status is <b>Closed</b> in <b>Overview &gt; Sampling Info</b>, set this parameter to <b>Closed</b>.</li> </ul> </li> <li>• System cable connection (genset switch Off state feedback): DI2 (HV)</li> </ul>

Parameter	Description
<b>Power grid electricity restored to normal operation</b>	<ul style="list-style-type: none"> <li>This parameter is displayed when <b>Generator set control</b> is set to <b>Enable</b>.</li> <li>Check the actual status of the grid power and the status received by DI3 (HV) (which can be viewed in <b>Overview &gt; Sampling Info</b>). <ul style="list-style-type: none"> <li>If the grid power is recovered and the port status is <b>Open</b> in <b>Overview &gt; Sampling Info</b>, set this parameter to <b>Open</b>.</li> <li>If the grid power is recovered and the port status is <b>Closed</b> in <b>Overview &gt; Sampling Info</b>, set this parameter to <b>Closed</b>.</li> </ul> </li> <li>System cable connection (grid power recovery state feedback): DI3 (HV)</li> </ul>

**NOTICE**

Connect cables strictly according to the preceding table. Otherwise, the related functions cannot be enabled.

## Off-Grid

**Table 6-137** Microgrid settings

Parameter	Description
<b>MGCC mode</b>	The value is displayed as <b>Enable</b> . You can choose <b>Monitoring &gt; Logger &gt; Running Parameters &gt; Scenario</b> to set the parameter.

**Table 6-138** Connection settings

Parameter	Description
<b>Critical load switch</b>	<ul style="list-style-type: none"> <li>Specifies whether the critical load switch is connected.</li> <li>System cable connections: <ul style="list-style-type: none"> <li>DI1 (HV): reports the Off state of the critical load switch.</li> <li>DO1 (HV): turns on the critical load switch.</li> <li>DO2 (HV): turns off the critical load switch.</li> </ul> </li> </ul>

Parameter	Description
<p><b>Valid if critical load switch is off</b></p>	<p>Check the actual status of the critical load switch and the status received by DI1 (HV) (which can be viewed in <b>Overview &gt; Sampling Info</b>).</p> <ul style="list-style-type: none"> <li>● If the actual status of the switch is Off and the port status is <b>Open</b> in <b>Overview &gt; Sampling Info</b>, set this parameter to <b>Open</b>.</li> <li>● If the actual status of the switch is Off and the port status is <b>Closed</b> in <b>Overview &gt; Sampling Info</b>, set this parameter to <b>Closed</b>.</li> </ul>
<p><b>Minor load switch</b></p>	<ul style="list-style-type: none"> <li>● Specifies whether the minor load switch is connected.</li> <li>● System cable connections: <ul style="list-style-type: none"> <li>– DI2 (HV): reports the Off state of the minor load switch.</li> <li>– DO3 (HV): turns on the minor load switch.</li> <li>– DO4 (HV): turns off the minor load switch.</li> </ul> </li> </ul>
<p><b>Valid if minor load switch is off</b></p>	<p>Check the actual status of the minor load switch and the status received by DI2 (HV) (which can be viewed in <b>Overview &gt; Sampling Info</b>).</p> <ul style="list-style-type: none"> <li>● If the actual status of the switch is Off and the port status is <b>Open</b> in <b>Overview &gt; Sampling Info</b>, set this parameter to <b>Open</b>.</li> <li>● If the actual status of the switch is Off and the port status is <b>Closed</b> in <b>Overview &gt; Sampling Info</b>, set this parameter to <b>Closed</b>.</li> </ul>
<p><b>Common load switch</b></p>	<ul style="list-style-type: none"> <li>● Specifies whether the common load switch is connected.</li> <li>● System cable connections: <ul style="list-style-type: none"> <li>– DI3 (HV): reports the Off state of the common load switch.</li> <li>– DO5 (HV): turns on the common load switch.</li> <li>– DO6 (HV): turns off the common load switch.</li> </ul> </li> </ul>
<p><b>Valid if common load switch is off</b></p>	<p>Check the actual status of the common load switch and the status received by DI3 (HV) (which can be viewed in <b>Overview &gt; Sampling Info</b>).</p> <ul style="list-style-type: none"> <li>● If the actual status of the switch is Off and the port status is <b>Open</b> in <b>Overview &gt; Sampling Info</b>, set this parameter to <b>Open</b>.</li> <li>● If the actual status of the switch is Off and the port status is <b>Closed</b> in <b>Overview &gt; Sampling Info</b>, set this parameter to <b>Closed</b>.</li> </ul>
<p><b>Generator set control</b></p>	<p>Specifies whether to set <b>Generator set control</b> to <b>Enable</b>.</p>

Parameter	Description
<b>Generator Set Control Method</b>	<ul style="list-style-type: none"> <li>• This parameter is displayed when <b>Generator set control</b> is set to <b>Enable</b>.</li> <li>• Pulse control mode:                             <ul style="list-style-type: none"> <li>– DO5 (HV): starts the genset.</li> <li>– DO6 (HV): shuts down the genset.</li> </ul> </li> <li>• Level control mode:                             <ul style="list-style-type: none"> <li>– DO5 (HV): starts the genset at high level when closed.</li> <li>– DO6 (HV): starts the genset at low level when open.</li> </ul> </li> </ul>
<b>Switch disconnection effective state</b>	<ul style="list-style-type: none"> <li>• Check the actual status of the transfer switch and the status received by DI4 (HV) (which can be viewed in <b>Overview &gt; Sampling Info</b>).                             <ul style="list-style-type: none"> <li>– If the actual status of the switch is Off and the port status is <b>Open</b> in <b>Overview &gt; Sampling Info</b>, set this parameter to <b>Open</b>.</li> <li>– If the actual status of the switch is Off and the port status is <b>Closed</b> in <b>Overview &gt; Sampling Info</b>, set this parameter to <b>Closed</b>.</li> </ul> </li> <li>• System cable connections:                             <ul style="list-style-type: none"> <li>– DI4 (HV): reports the Off state of the transfer switch.</li> <li>– DO3 (HV): turns on the transfer switch.</li> <li>– DO4 (HV): turns off the transfer switch.</li> </ul> </li> </ul>

**NOTICE**

Connect cables strictly according to the preceding table. Otherwise, the related functions cannot be enabled.

### 6.6.5.2 Scheduling Control

 **NOTE**

Path: **Set > Microgrid Control > Scheduling Control**

## Control Policy Parameters (On/Off-Grid)

Table 6-139 Array SOC parameters

Parameter	Description	Remarks
<b>Array end-of-charge SOC</b>	Specifies the array end-of-charge SOC. When the SOC of the ESS reaches the preset value, the ESS stops charging.	-
<b>Array end-of-discharge SOC</b>	Specifies the array end-of-discharge SOC. When the SOC of the ESS reaches the preset value, the ESS stops discharging.	-
<b>Backup power SOC for capacity/demand control</b>	The reserved power, which is used for capacity/demand control, ensures that the ESS can meet capacity/demand control requirements. The value of this parameter affects the peak shaving capability. A larger value indicates a stronger peak shaving capability.	This parameter is displayed when <b>Demand limit</b> is set to <b>Active power limit</b> or <b>Apparent power limit</b> , or <b>Capacity limit</b> is set to <b>Current limit</b> .
<b>Max. SOC for charging on/off-grid ESS</b>	<ul style="list-style-type: none"> <li>Seamed switching scenario: maximum SOC for charging the ESS in off-grid mode</li> <li>Seamless switching scenario: maximum SOC for charging the ESS in on-grid or off-grid mode</li> </ul>	-
<b>Min. SOC for discharging on/off-grid ESS</b>	<ul style="list-style-type: none"> <li>Seamed switching scenario: minimum SOC for discharging the ESS in off-grid mode</li> <li>Seamless switching scenario: minimum SOC for discharging the ESS in on-grid or off-grid mode</li> </ul>	-

 NOTE

- On/Off-grid scenario: **Array end-of-discharge SOC < Min. SOC for discharging on/off-grid ESS < Min. SOC for off-grid power backup < Backup power SOC for capacity/demand control < Max. SOC for charging on/off-grid ESS < Array end-of-charge SOC**
- Off-grid scenario: **Array end-of-discharge SOC < Min. SOC for discharging off-grid ESS < SOC for turning on/off load switch < Max. SOC for charging off-grid ESS < Array end-of-charge SOC**

**Table 6-140** Black start parameters

Parameter	Description	Remarks
<b>Min. PV voltage for black start</b>	After the irradiance recovers, the inverter PV voltage increases. If the PV1 voltage of an inverter is greater than or equal to the value of this parameter, the black start may be started.	This parameter is displayed when <b>Automatic black start after irradiance restoration</b> is set to <b>Enable</b> .
<b>Min. estimated power for black start</b>	Before setting this parameter, ensure that the southbound inverter supports irradiance estimation. Set this parameter to a percentage of the ESS rated power. The default value is 10% of the ESS rated power. When the irradiance is restored, if the estimated PV output power of the inverter is greater than the minimum estimated power for the black start, the black start is automatically performed.	

**Table 6-141** Off-grid power backup

Parameter	Description	Remarks
<b>Off-grid power backup</b>	Specifies whether to enable <b>Off-grid power backup</b> . When the SOC is less than or equal to <b>Min. SOC for off-grid power backup</b> , the ESS stops discharging to maintain sufficient power for off-grid operation.	-
<b>Min. SOC for off-grid power backup</b>	Specifies the minimum SOC for off-grid power backup.	This parameter is displayed when <b>Off-grid power backup</b> is set to <b>Enable</b> .
<b>Prioritize off-grid power backup</b>	Specifies whether to set <b>Prioritize off-grid power backup</b> to <b>Enable</b> . If the ESS SOC is less than or equal to the min. SOC for off-grid power backup minus 3%, the ESS is preferentially charged from the PV power or grid power.	-

Parameter	Description	Remarks
<b>Draw power from grid for off-grid power backup</b>	Specifies whether to obtain power from the grid for off-grid power backup.	This parameter is displayed when <b>Prioritize off-grid power backup</b> is set to <b>Enable</b> .
<b>Charge power for off-grid power backup</b>	Specifies the power for charging the ESS by the grid for off-grid power backup. If the ESS control policy is set to <b>TOU</b> (see <a href="#">Table 6-123</a> ) and <b>Draw power from grid for off-grid power backup</b> is triggered, this parameter instead of <b>Maximum charge power from AC</b> determines the grid power charged to the ESS. You are advised to set this parameter to the same value as <b>Maximum charge power from AC</b> .	This parameter is displayed when <b>Draw power from grid for off-grid power backup</b> is set to <b>Allow</b> .

Table 6-142 Voltage baseline

Parameter	Description	Remarks
<b>Off-grid voltage reference source</b>	<ul style="list-style-type: none"> <li>• <b>PCS port voltage:</b> The voltage level of the PCS is used as the baseline.</li> <li>• <b>Voltage at grid connection point or load side:</b> The setting of <b>Voltage baseline</b> is used as the baseline.</li> </ul>	-
<b>Voltage baseline</b>	Specifies the voltage baseline as the off-grid voltage reference source.	This parameter is displayed when <b>Off-grid voltage reference source</b> is set to <b>Voltage at grid connection point or load side</b> .

**Table 6-143** Genset control parameters

Parameter	Description	Remarks
<b>Generator Set Start-up Energy Storage SOC</b>	When the ESS SOC reaches the preset value, the genset starts.	This parameter is displayed when <b>Generator set control</b> is set to <b>Enable</b> .
<b>Generator set stops energy storage SOC</b>	When the ESS SOC reaches the preset value, the genset stops.	
<b>Generator Set Start/ Stop Judgment Time</b>	Specifies the time for determining whether to start or stop the genset.	
<b>Maximum output power ratio of the generator set</b>	Specifies the maximum output power ratio of the genset.	
<b>Rated active power of the generator set</b>	Specifies the rated active power of the genset.	

## Control Policy Parameters (Off-Grid)

**Table 6-144** Array SOC parameters

Parameter	Description	Remarks
<b>Array end-of-charge SOC</b>	Specifies the array end-of-charge SOC. When the SOC of the ESS reaches the preset value, the ESS stops charging.	-
<b>Array end-of-discharge SOC</b>	Specifies the array end-of-discharge SOC. When the SOC of the ESS reaches the preset value, the ESS stops discharging.	-
<b>Backup power SOC for capacity/demand control</b>	The reserved power, which is used for capacity/demand control, ensures that the ESS can meet capacity/demand control requirements. The value of this parameter affects the peak shaving capability. A larger value indicates a stronger peak shaving capability.	This parameter is displayed when <b>Demand limit</b> is set to <b>Active power limit</b> or <b>Apparent power limit</b> , or <b>Capacity limit</b> is set to <b>Current limit</b> .

Parameter	Description	Remarks
<b>Max. SOC for charging off-grid ESS</b>	Specifies the maximum SOC for charge in off-grid state.	-
<b>Min. SOC for discharging off-grid ESS</b>	Specifies the minimum SOC for discharge in off-grid state.	-
<b>SOC for turning on critical load switch</b>	When the array SOC is greater than or equal to the value, the critical load switch is turned on.	<ul style="list-style-type: none"> <li>• These parameters are displayed when the critical load switch is connected.</li> <li>• <b>SOC for turning on critical load switch &gt; SOC for turning off critical load switch</b></li> </ul>
<b>SOC for turning off critical load switch</b>	When the array SOC is less than or equal to the value, the critical load switch is turned off.	
<b>SOC for turning on minor load switch</b>	When the array SOC is greater than or equal to the value, the minor load switch is turned on.	<ul style="list-style-type: none"> <li>• These parameters are displayed when the minor load switch is connected.</li> <li>• <b>SOC for turning on minor load switch &gt; SOC for turning off minor load switch</b></li> </ul>
<b>SOC for turning off minor load switch</b>	When the array SOC is less than or equal to the value, the minor load switch is turned off.	

Parameter	Description	Remarks
<b>SOC for turning on common load switch</b>	When the array SOC is greater than or equal to the value, the common load switch is turned on.	<ul style="list-style-type: none"> <li>• These parameters are displayed when the common load switch is connected.</li> <li>• <b>SOC for turning on common load switch &gt; SOC for turning off common load switch</b></li> </ul>
<b>SOC for turning off common load switch</b>	When the array SOC is less than or equal to the value, the common load switch is turned off.	

 NOTE

- On/Off-grid scenario: **Array end-of-discharge SOC < Min. SOC for discharging on/off-grid ESS < Min. SOC for off-grid power backup < Backup power SOC for capacity/demand control < Max. SOC for charging on/off-grid ESS < Array end-of-charge SOC**
- Off-grid scenario: **Array end-of-discharge SOC < Min. SOC for discharging off-grid ESS < SOC for turning on/off load switch < Max. SOC for charging off-grid ESS < Array end-of-charge SOC**
- **SOC for turning on critical load switch < SOC for turning on minor load switch < SOC for turning on common load switch**
- **SOC for turning off critical load switch < SOC for turning off minor load switch < SOC for turning off common load switch**

**Table 6-145** Black start parameters

Parameter	Description	Remarks
<b>Min. PV voltage for black start</b>	After the irradiance recovers, the inverter PV voltage increases. If the PV1 voltage of an inverter is greater than or equal to the value of this parameter, the black start may be started.	This parameter is displayed when <b>Automatic black start after irradiance restoration</b> is set to <b>Enable</b> .

Parameter	Description	Remarks
<b>Min. estimated power for black start</b>	Before setting this parameter, ensure that the southbound inverter supports irradiance estimation. Set this parameter to a percentage of the ESS rated power. The default value is 10% of the ESS rated power. When the irradiance is restored, if the estimated PV output power of the inverter is greater than the minimum estimated power for the black start, the black start is automatically performed.	

**Table 6-146** Voltage baseline

Parameter	Description	Remarks
<b>Off-grid voltage reference source</b>	<ul style="list-style-type: none"> <li>• <b>PCS port voltage:</b> The voltage level of the PCS is used as the baseline.</li> <li>• <b>Voltage at grid connection point or load side:</b> The setting of <b>Voltage baseline</b> is used as the baseline.</li> </ul>	-
<b>Voltage baseline</b>	Specifies the voltage baseline as the off-grid voltage reference source.	This parameter is displayed when <b>Off-grid voltage reference source</b> is set to <b>Voltage at grid connection point or load side</b> .

**Table 6-147** Genset control parameters

Parameter	Description	Remarks
<b>Generator Set Start-up Energy Storage SOC</b>	When the ESS SOC reaches the preset value, the genset starts.	This parameter is displayed when <b>Generator set control</b> is set to <b>Enable</b> .
<b>Generator set stops energy storage SOC</b>	When the ESS SOC reaches the preset value, the genset stops.	

Parameter	Description	Remarks
<b>Generator Set Start/ Stop Judgment Time</b>	Specifies the time for determining whether to start or stop the genset.	
<b>Maximum output power ratio of the generator set</b>	Specifies the maximum output power ratio of the genset.	
<b>Rated active power of the generator set</b>	Specifies the rated active power of the genset.	

## On/Off Control

Table 6-148 On/Off control

Parameter	Description	Remarks
<b>Generator Set Switching Status</b>	Controls whether to connect the genset to the microgrid.	This parameter is displayed when <b>Generator set control</b> is set to <b>Enable</b> .
<b>Status of switch at grid connection point</b>	Displays the status of the switch at the grid connection point. You can click <b>On</b> or <b>Off</b> to control the switch at the grid connection point.	This parameter is displayed when <b>Scenario</b> is set to <b>On/Off-grid</b> and <b>Automatic on/off-grid switching mode</b> is set to <b>Not controlled</b> .
<b>Automatic load control status</b>	Displays the automatic load control status.	This parameter is displayed when <b>Scenario</b> is set to <b>Off-grid</b> and the relevant load switch is connected.
<b>Critical load switch status</b>	Display whether loads are connected or disconnected. This function is used to detect the load switch status. Before the detection, shut down the array.	
<b>Minor load switch status</b>		
<b>Common load switch status</b>		

### 6.6.5.3 On/Off-Grid Switching

 NOTE

- Path: **Set > Microgrid Control > On/Off-Grid Switching**
- **On/Off-Grid Switching** is displayed when **Scenario** is set to **On/Off-grid** and the following conditions are met:
  - **Automatic on/off-grid switching mode** is set to **Seamless switching**.
  - **Automatic on/off-grid switching mode** is set to **Seamed switching** and **Seamed on/off-grid switching mode** is set to **Automatic**.

**Table 6-149** General configuration

Parameter	Description
<b>Auto switching to on-grid</b>	<ul style="list-style-type: none"> <li>• <b>Enable:</b> If the mains voltage is stable, the system automatically switches from off-grid to on-grid state after the synchronization of the SmartMGC is successful.</li> <li>• <b>Disable:</b> The function of automatic switching from off-grid to on-grid state is disabled.</li> </ul>
<b>Setting value of live voltage</b>	Specifies the allowed error range of the mains voltage.
<b>Continuous power available for</b>	Specifies the minimum time for which the mains voltage remains stable.
<b>Max switching time</b>	This parameter is displayed when <b>Automatic on/off-grid switching mode</b> is set to <b>Seamless switching</b> . It specifies the maximum duration for switching from off-grid to on-grid. The value must be greater than the synchronization check duration of the SmartMGC.

**Table 6-150** Switching control

Parameter	Description
<b>On/Off-grid status</b>	Displays the on/off-grid status. You can click <b>Switch to on-grid</b> or <b>Switch to off-grid</b> to switch between on-grid and off-grid.
<b>Status of switching to off-grid</b>	
<b>Status of switching to on-grid</b>	

## 6.6.5.4 Advanced Control Configuration

 NOTE

- **Protective Relay Configuration** is displayed when **Scenario** is set to **On/Off-grid** and **Automatic on/off-grid switching mode** is set to **Seamless switching**.
- **On/Off-Grid Switching Configuration** is displayed when **Scenario** is set to **On/Off-grid** and the following conditions are met.
  - **Automatic on/off-grid switching mode** is set to **Seamless switching**.
  - **Automatic on/off-grid switching mode** is set to **Seamed switching** and **Seamed on/off-grid switching mode** is set to **Automatic**.
- For the parameters on the **Off-Grid Steady-State Configuration**, **Protective Relay Configuration**, and **On/Off-Grid Switching Configuration** pages, contact Huawei engineers for configuration instructions.

## Control Policy Configuration

 NOTE

Path: **Set > Microgrid Control > Advanced Control Configuration > Control Policy Configuration**

**Table 6-151** Control policy configuration

Parameter	Description
<b>Automatic PCS recovery</b>	<ul style="list-style-type: none"> <li>• <b>Enable:</b> During off-grid operation, when the SmartMGC detects that the PCS shuts down abnormally and causes microgrid power failure, the SmartMGC automatically attempts to perform black start to restore the power supply.</li> <li>• <b>Disable:</b> If the PCS shuts down abnormally, the SmartMGC does not automatically perform black start.</li> </ul>
<b>Automatic black start retries upon PCS fault</b>	This parameter is displayed when <b>Automatic PCS recovery</b> is set to <b>Enable</b> . Set <b>Automatic black start retries upon PCS fault</b> .
<b>Automatic black start after irradiance restoration</b>	<ul style="list-style-type: none"> <li>• <b>Enable:</b> During off-grid operation, automatic black start is performed after the irradiance restores.</li> <li>• <b>Disable:</b> Automatic black start is not performed after the irradiance restores.</li> </ul>
<b>PV charging upon black start</b>	This parameter is displayed when <b>Scenario</b> is set to <b>Off-grid</b> . It specifies whether to set <b>PV charging upon black start</b> to <b>Enable</b> . If the current SOC of the ESS is too low, black start may fail. If this parameter is set to <b>Enable</b> , black start can be performed when the irradiance is sufficient.

Parameter	Description
<b>Automatic load connection/shedding</b>	This parameter is displayed when <b>Scenario</b> is set to <b>Off-grid</b> . It specifies whether to set <b>Automatic load connection/shedding</b> to <b>Enable</b> . When you manually operate the load switch, this function is temporarily locked. This function can be restored only after this parameter is set to <b>Enable</b> or the black start is successful.

## 6.6.6 Dry Contact Settings

### NOTICE

- It is recommended that the transmission distance of dry contact signals be less than or equal to 10 m.
- When setting the functions related to dry contacts, ensure that the ports are not occupied.

## Remote Shutdown via Dry Contact

The SmartMGC provides four DI ports, any of which can be connected to the OVGR. The SmartMGC controls the inverter shutdown using the OVGR signal. This function applies only to Japan.

### NOTE

Path: **Set > Dry Contact Settings > Remote Shutdown via Dry Contact**

**Table 6-152** Remote shutdown via dry contact

Parameter	Description
<b>Connected port</b>	Specifies the port for function interconnection.
<b>DI port status</b>	Specifies the dry contact status for triggering the OVGR signal to shut down the inverter.
<b>OVGR shutdown</b>	Specifies whether to enable shutdown over OVGR.
<b>Cubicle alarm</b>	<ul style="list-style-type: none"> <li>• <b>Disable</b>: No cubicle alarm is generated.</li> <li>• <b>Enable</b>: If the cubicle is abnormal, a cubicle alarm is generated when the dry contact signal is valid.</li> </ul>

## NS protection for remote shutdown

**NOTE**

Path: **Set > Dry Contact Settings > NS Protection for Remote Shutdown**

- The NS protection function applies to areas that comply with the VDE4105 standard. You need to set the grid code of the device to **VDE-AR-N-4105** or **SWITZERLAND-NA/EEA:2020-LV230**.
- Connect the NS protection device to the AI/DI 1+ port and 12V power output port on the SmartMGC. The SmartMGC shuts down the inverter if voltage change is detected at the AI/DI 1+ port. When the NS protection device is disconnected, the voltage of the AI/DI 1+ port is 0 V and the inverter shuts down. When the NS protection device is connected again, the voltage of the AI/DI 1+ port is 12 V and the inverter needs to be manually started.

**Figure 6-26** Networking diagram

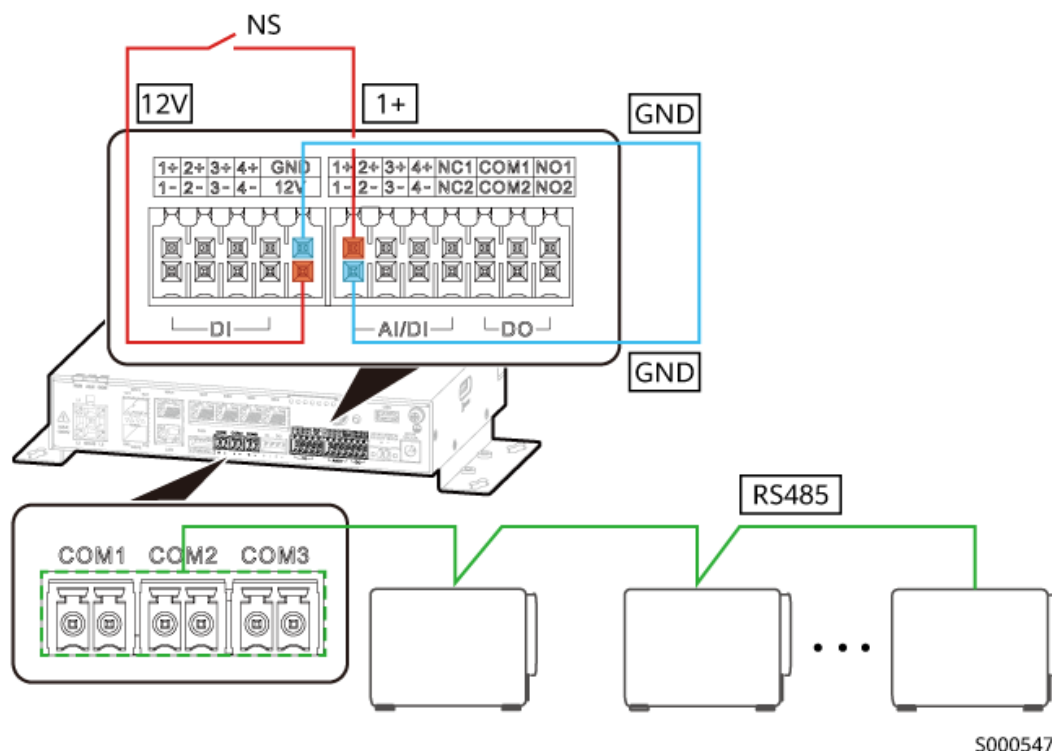

S000547

**NOTE**

If the inverter is connected using an RS485 communications cable, connect the cable to the RS485-1 port of the inverter.

**Table 6-153** NS protection for remote shutdown

Parameter	Description
Connected port	Specifies the port for function interconnection.

**NOTICE**

The duration from the time when the SmartMGC receives a shutdown command to the time when the inverter shuts down is less than 150 ms. The third-party protection device adopted should detect the delivered command within 50 ms.

## Optimizer Rapid Shutdown

 **NOTE**

Path: **Set > Dry Contact Settings > Optimizer Rapid Shutdown**

**NOTICE**

- Before enabling this function, set **Rapid shutdown if inverter communication fails** to **Enable**. For details, see [6.4.2 Inverter](#).
- If optimizers are configured for all PV modules connected to the inverter, the PV system can perform a rapid shutdown. The rapid shutdown function is not supported if optimizers are configured for some PV modules.
- By default, the switch is turned on. If the switch is turned off, rapid shutdown is triggered. The string output voltage can be reduced to less than 120 V within 15s and less than 30 V within 30s.

**Table 6-154** Optimizer rapid shutdown

Parameter	Description
<b>Fast shutdown</b>	Specifies whether to enable optimizer rapid shutdown.
<b>Connected port</b>	Specifies the port for switch connection.
<b>Feedback port</b>	Specifies the port for switch status feedback.

## 6.6.7 License Management

 **NOTE**

Path: **Set > License Management**.

### License Info

**Table 6-155** License info

Authorized Feature	Device	How to Obtain
<b>Smart I-V Curve Diagnosis</b>	Inverter	Purchase

Authorized Feature	Device	How to Obtain
Smart string monitoring	Inverter	N/A
Smart insulation monitoring	PID	Purchase
Smart PV grid forming	SmartMGC	Purchase
SDS	SmartMGC	Purchase
Smart grid forming feature - microgrid	SmartMGC	Purchase
Smart grid forming feature - on-grid	SmartMGC	Purchase

## License Management

Table 6-156 License management

Tab	Description
License Info	Views the license information and exports the license details.
License Application	Exports the license application file, purchases a license, and obtains the license file from technical support engineers.
License Activation	Loads the obtained license file to the device and activates the license. You can import a license file in .dat or .xml format or a .zip package (containing a license file in .dat or .xml format).
License Revocation	Revokes a license or exports the revocation code file.

## 6.7 Maintenance

### 6.7.1 Device Management

#### 6.7.1.1 Device Access

 NOTE

Path: **Maintenance > Device Management > Device Access**

## Search

**Step 1** Click **Search**. The dialog box for confirming device search is displayed.

**Step 2** Click **OK** to search for non-third-party devices that have been connected to the system.

----End

## Add

**Step 1** Click **Add**. The dialog box for adding devices is displayed.

**Step 2** Select **Device Type** and set the parameters based on the selected **Device Type**.

**Step 3** Click **Add**.

----End

### NOTE

- Before connecting to a charger, enable Modbus TCP on the charger.
- Before connecting to a charger, disable the DHCP function for the charger and manually set the IP address of the charger. The IP address must be the same as that of the network port connected to the SmartMGC.
- After a DC charger developed by the Company is connected to the SmartMGC, complete configuration by referring to section "Software Settings" in the [FusionCharge Third-Party Energy Management System Interconnection Guide](#).

## Delete

**Step 1** Select the devices to be deleted.

**Step 2** Click **Delete** to access the confirmation dialog box.

**Step 3** Click **OK**.

----End

## Import

The SmartMGC can connect to third-party devices that support the standard Modbus-RTU protocol. The protocol signals vary depending on vendors. Therefore, you need to configure a protocol signal file in .cfg format and import it to the SmartMGC so that third-party devices can be connected. A protocol signal file in .cfg format must be generated using the customized device configuration table (provided with the release documentation).

**Step 1** Open the customized device configuration table.

**Step 2** Modify the configuration parameters according to the device requirements, and generate a protocol signal file in .cfg format.

**Step 3** Click **Import** to access the import dialog box.

**Step 4** Add the protocol signal file in .cfg format, and click **Import**.

----End

## Export

Click **Export** to export the third-party device information file.

### 6.7.1.2 Device List

#### NOTE

Path: **Maintenance > Device Management > Device List**

## Modifying Information

**Step 1** Click the edit icon in the operation column. The device information is editable.

**Step 2** Modify the device information.

**Step 3** Click ✓.

----End

### 6.7.1.3 Device Update

## Software Package Management

#### NOTE

- Path: **Maintenance > Device Management > Device Update > Software Package Management**
- Contact the Company's engineers to obtain the software package.
- If multiple software packages are selected for the same device type, the system retains only the software package that is successfully uploaded last.
- **Uploading a software package**
  - a. Click **Upload**. The dialog box for software package information is displayed.
  - b. Upload the software package of the target version.
  - c. Click **Upload**.
- **Deleting a software package**
  - a. Select the software package to be deleted.
  - b. Click **Delete**. The dialog box for deleting the software package is displayed.
  - c. Click **OK**.

## Device Update

#### NOTE

Path: **Maintenance > Device Management > Device Update > Device Update**

---

**NOTICE**

- Before upgrading the PCS and inverter, ensure that the DC side is powered on.
  - Before upgrading the inverter, you are advised to disable the inverter function of protection upon communication failure to prevent active power derating during the upgrade.
  - If the device version rollback fails, the **Upgrade rollback prevention** function of the device has been set to **Enable**. You can modify the setting of the **Upgrade rollback prevention** function by referring to [6.4 Monitoring](#).
  - If the active power control mode is **Limited feed-in** or **Remote Scheduling**, the reactive power control mode is **Power factor closed-loop control**, and the ESS working mode is not **No control**, you are advised to upgrade the software when the inverter and PCS are disconnected from the grid. Otherwise, the power control may be abnormal or the upgrade may fail.
  - During the upgrade of the SmartMGC, the SmartMGC control functions may become invalid, for example, power control may be abnormal or on/off-grid switching may fail.
- 

**Step 1** Select the device to be upgraded.

**Step 2** Click **Update** to complete the device update.

----End

### 6.7.1.4 Device Logs

 **NOTE**

Path: **Maintenance > Device Management > Device Log**

**Step 1** Select the devices whose logs need to be exported.

**Step 2** Click **Export**. The log export dialog box is displayed.

**Step 3** Select **Log type** and enter **Encryption password** (optional).

**Step 4** Click **OK**.

----End

---

**NOTICE**

- Before exporting inverter logs, you are advised to disable the inverter function of protection upon communication failure to prevent active power derating during log export.
  - If the active power control mode is **Limited feed-in** or **Remote Scheduling**, the reactive power control mode is **Power factor closed-loop control**, and the ESS working mode is not **No control**, you are advised to export logs when the inverter or PCS is disconnected from the grid. Otherwise, the power control may be abnormal or the log export may fail.
-

### 6.7.1.5 Startup/Shutdown

 NOTE

Path: **Maintenance > Device Management > Startup/Shutdown**

**Step 1** Select the devices for which **Start**, **Shut Down**, or **Reset** needs to be performed.

**Step 2** Click **Start**, **Shut Down**, or **Reset** and select **Selected devices** from the drop-down list to start, shut down, or reset the devices.

----End

### 6.7.1.6 Black Start

 NOTE

Path: **Maintenance > Device Management > Black Start.**

**Table 6-157** Black start

Parameter	Description
<b>Stable SOC</b>	Specifies the stable-state SOC of the ESS. If the SOC is too low, black start may fail.
<b>Black start progress</b>	Displays the black start progress.
<b>Current Status</b>	Displays the current black start status.
<b>Failure cause</b>	If the black start fails, the failure cause is displayed.

### Automatic Black Start

If the current ESS SOC is higher than the minimum ESS SOC required for black start, automatic black start is triggered if certain conditions are met.

- When **Scenario** is set to **On/Off-grid**, **MGCC mode** is set to **Enable**, and the on/off-grid switching mode is set to **Auto**, black start is automatically triggered if the plant is switched from on-grid to off-grid operation due to mains outage.
- When **Scenario** is set to **On/Off-grid**, **MGCC mode** is set to **Enable**, and the on/off-grid switching mode is set to **Manual**, black start is automatically triggered if you turn off the on/off-grid switch locally to switch the plant from on-grid to off-grid operation manually.
- When **MGCC mode** is set to **Enable** and **Automatic PCS recovery** is set to **Enable**, black start is automatically triggered if the voltage on the PCS AC side is abnormal (less than 30% of the rated voltage on the PCS AC side) and the PCS is shut down abnormally.
- When **Scenario** is set to **Off-grid** and **MGCC mode** is set to **Enable**, if the solar irradiance recovers for inverters, turn off the load switch and then the black start is automatically triggered.

## Manual Black Start

**Step 1** Check that the current ESS SOC is greater than or equal to 3%.

**Step 2** Click **Black Start** to complete the manual black start.

----End

### NOTE

If the current ESS SOC is less than 3%, the black start may fail. You are advised to perform the black start when the solar irradiance is sufficient.

## 6.7.1.7 Data Re-collection

### NOTE

Path: **Maintenance > Device Management > Data Re-collection**

**Step 1** Select the device whose data needs to be re-collected.

**Step 2** Click **Start**. The dialog box for setting the data type for recollection is displayed.

**Step 3** Specify the re-collection interval for each data type.

**Step 4** Click **.OK**

----End

## 6.7.1.8 Device Replacement

### NOTE

- Path: **Maintenance > Device Management > Device Replacement**
- Before device replacement, add the new device (that is, the device used for replacement). For details, see [6.7.1.1 Device Access](#).
- After device replacement, access the **Running Parameters** page of the device, select online devices of the same type, and click **Batch Sync** to synchronize parameters for devices that have been replaced. For details, see [6.4 Monitoring](#).

**Step 1** Enter information such as the device type, old device SN, and new device SN, and click **Next**.

**Step 2** On the **Confirm information** page, confirm the entered information.

**Step 3** Click **OK**.

----End

**NOTICE**

- Device replacement applies only to devices of the same type and model.
- Only the grid code, logical address, and IEC 104 configuration of the old device can be synchronized to the new device.
- If only one device exists in the system, you are advised to record the configurable parameters of the old device. After device replacement, set the new device by referring to the recorded parameters.
- Do not restart the SmartMGC during inverter replacement.

## 6.7.2 Security Management

### 6.7.2.1 User Management

On the user management page, you can view the information about each account, modify the username, password, or permission of an existing user, or add a user.

**NOTE**

- Path: **Maintenance > Security Management > User Management**
- **User Management** is displayed only after you log in to the system as an administrator.

### User Addition

**Step 1** Click **Add**. The dialog box for user addition is displayed.

**Step 2** Enter information such as **Username**, **Password**, and **Permission**.

**Step 3** Click **OK**.

----End

### Permission Description

Table 6-158 WebUI user permissions

First-Level Menu	Administrator	Advanced User	Common User
Overview	Supported	Supported	Supported
Monitoring	Supported	Supported	Parameter setting functions such as <b>Running Parameters</b> and <b>Characteristic Curve</b> are not supported.
Query	Supported	Supported	Only <b>Historical Alarms</b> and <b>Security Events</b> are supported.

First-Level Menu	Administrator	Advanced User	Common User
Set	Supported	Supported	Only is supported.
Maintenance	Supported	User Management in Security Management and Clear All Data in System Maintenance are not supported.	Only Security Settings is supported.

## 6.7.2.2 Certificate Management

### NOTE

Path: **Maintenance > Security Management > Certificate Management**

## Certificate Update

Table 6-159 Certificate update

Parameter	Description
Initial certificate type	Select the certificate type.
Upload CA certificate file	Upload a certificate file.
Upload local certificate file	
Upload key file	
Key password	Enter the key password and confirm it.
Confirm key password	

## CRL

Table 6-160 CRL

Parameter	Description
Initial certificate type	Select the certificate type.
CRL file	Upload the CRL file.

## Expiration Detection

Table 6-161 Expiration detection

Parameter	Description
<b>Expiration detection interval</b>	Specifies the interval for detecting certificate expiration.
<b>Advance warning time</b>	Specifies the time for warning of certificate expiration in advance.
<b>Communication using expired certificate</b>	<ul style="list-style-type: none"> <li>• <b>Enable:</b> Communication remains allowed after the certificate expires.</li> <li>• <b>Disable:</b> Communication is immediately terminated after the certificate expires.</li> </ul>

## Security Algorithm

Table 6-162 Security algorithm

Parameter	Description
<b>Initial communication certificate signature algorithm</b>	Specify whether to enable the algorithms.
<b>Software integrity protection signature algorithm</b>	

### 6.7.2.3 Security Settings

 NOTE

Path: **Maintenance > Security Management > Security Settings**

Table 6-163 Password policy

Parameter	Description
<b>Min. characters</b>	<ul style="list-style-type: none"> <li>• Set the password composition rules according to the actual situation.</li> <li>• After the password policy is updated, it takes effect for new passwords immediately but has no impact on existing passwords.</li> <li>• The password must contain 8 to 64 characters, which are at least two types of the following characters: uppercase letters, lowercase letters, digits, and special characters.</li> </ul>
<b>Max. characters</b>	
<b>Min. character types</b>	
<b>Min. special characters</b>	

**Table 6-164** Machine-machine password for southbound device

Parameter	Description
<b>Machine-Machine Password for Southbound Device</b>	If the SmartModule cannot connect to the SmartMGC, change the password to <b>/EzFp+2%r6@IxSCv</b> . After the connection is successful, upgrade the SmartModule software to the latest version.

**Table 6-165** Device login password

Parameter	Description
<b>Device Login Password</b>	Change the login password of the SmartMGC.

**Table 6-166** Session timeout policy

Parameter	Description
<b>Timeout interval</b>	Specifies the period within which if no operation is performed, the system automatically logs out the current account.

**Table 6-167** Account lockout policy

Parameter	Description
<b>Check interval</b>	Specifies the check interval.
<b>Consecutive failures</b>	The account is locked if the number of login failures exceeds the value of this parameter.
<b>Lock duration</b>	Specifies the account lockout duration.

**Table 6-168** SSH

Parameter	Description
<b>SSH</b>	Specifies whether to enable the SSH protocol. If this parameter is set to <b>Enable</b> , security risks may exist.

**Table 6-169** Intrusion detection

Parameter	Description
<b>Intrusion Detection</b>	Specifies whether to enable <b>Intrusion Detection</b> .

**Table 6-170** Key update

Parameter	Description
<b>Key update interval</b>	Specifies the interval at which the key is automatically updated.

### 6.7.2.4 Password Reset

 **NOTE**

- Path: **Maintenance > Security Management > Password Reset**
- This function is used only to reset the password for logging in to the inverter on the app locally.
- The verification code is valid for 4 hours. Reset the password of the target device within the validity period.

**Step 1** Select the device for which the password needs to be reset.

**Step 2** Click **Reset** to obtain the verification code (the verification code is displayed on the page).

**Step 3** Use the verification code to reset the password for logging in to the device on the app locally.

----End

### 6.7.3 System Maintenance

 **NOTE**

Path: **Maintenance > System Maintenance**

**Table 6-171** System maintenance

Function Name	Description
<b>Reset System</b>	Restarts the SmartMGC. The communication with external devices will be interrupted temporarily during the restart.

Function Name	Description
<b>Restore Default Settings</b>	After the default settings are restored, only the key settings (time, date, communication parameters, and environment parameters) and passwords required for system operation are retained, and other parameters are restored to their default settings. Exercise caution when performing this operation.
<b>Clear Alarm Data</b>	Clears all active alarms and historical alarms.
<b>Clear Performance Data</b>	Clears all performance data and energy data.
<b>Clear All Data</b>	Clears all user data, restores signals to their defaults, and restores the Logger to its factory settings.
<b>Migrate Data</b>	Rapidly migrates data to the new device during SmartMGC device replacement. <b>NOTICE</b> User information on the old device cannot be migrated to the new device. The administrator needs to add the user information on the new device.

## 6.7.4 Field Test

After an inverter is put into use, you need to periodically check its health to detect risks and potential problems.

### 6.7.4.1 Terminal Test

#### NOTE

- Path: **Maintenance > Field Test > Terminal test**
- The terminal test function is available only for an inverter whose grid code is set to the Japanese standard.

**Step 1** Select the device to be inspected.

**Step 2** Click **Terminal test** to start the test.

**Step 3** Observe the test progress and wait until the test is complete. You can click **Cancel** to stop the test immediately.

----End

### 6.7.4.2 Inspection

#### NOTE

Path: **Maintenance > Field Test > Inspection**

**Step 1** Select the device to be inspected.

**Step 2** Click **Inspection** or **Quick inspection** (quick inspection does not include inverter I-V curve scanning) to start the inspection.

**Step 3** Observe the inspection progress and wait until the inspection is complete. You can click **Cancel** to stop the inspection immediately.

----End

### 6.7.4.3 Data Check

#### Teleindication

 **NOTE**

Path: **Maintenance > Field Test > Data Check > Teleindication**

- **Manual check**
  - a. Select the **Manual check** mode and click **Start**.
  - b. Change the **Analog Value** of a single signal to check the data of the signal.
  - c. Check the data of the remaining signals in sequence.
  - d. Click **Stop** to pause or complete the data check. All signals are reported based on the actual values.
- **Automatic check**
  - a. Select the **Auto check** mode.
  - b. Enter the **Interval** and **Start signal No.** for signal data check.
  - c. Click **Start**.
  - d. The system automatically completes the data check of the remaining signals from **Start signal No.**
  - e. Click **Stop** to pause or complete the data check. All signals are reported based on the actual values.

 **NOTE**

- During automatic check, you can switch pages, which does not affect the check process.
- If you click **Start**, the backend data of the system will no longer be updated. If you click **Stop**, the backend data of the system will be updated.
- After manual check, if you do not click **Stop** and do not perform any operation within 10 minutes, the system will automatically stop data check 10 minutes later. All signals are reported based on the actual values. After automatic check, the system will automatically stop data check in 10 minutes. All signals will be reported based on the actual values.

#### Telemetry

 **NOTE**

Path: **Maintenance > Field Test > Data Check > Telemetry**

**Step 1** Click **Start**. Data check is automatically performed for all signals.

**Step 2** (Optional) Click **Analog Value** of a signal to change the default **Analog Value**. The system automatically checks the signal with the new **Analog Value**.

**Step 3** Click **Stop** to pause or complete the data check. All signals are reported based on the actual values.

----End

 NOTE

- If you click **Start**, the backend data of the system will no longer be updated. If you click **Stop**, the backend data of the system will be updated.
- After telemetry signals are checked, click **Stop**. Otherwise, communication will be affected.

## 6.7.5 Recording Settings

Recording refers to the real-time collection and recording of parameters such as voltage and current in the power system.

 NOTE

Path: **Maintenance > Recording Settings**

**Table 6-172** Manual recording

Parameter	Description
<b>Manual Recording</b>	Click <b>Start</b> to start 2s waveform data recording immediately.

**Table 6-173** Recording by command

Parameter	Description
<b>Command validity period</b>	Click <b>Start</b> . After a remote scheduling command is received within the specified period, the 2s waveform data is recorded immediately.

**Table 6-174** Recording file

Parameter	Description
<b>Recording File</b>	Click <b>Export</b> to export the recording file.

## 6.7.6 Communication Record

 NOTE

Path: **Maintenance > Communication Record**

**Step 1** Select the corresponding port from the drop-down list.

**Step 2** Select the protocol type of the connected device.

**Step 3** Set the duration of communication recording.

**Step 4** Click **Start** to start communication recording.

**Step 5** Click **Export** to stop the recording and export communication records.

----End

## 6.7.7 Damage Detection

On the damage detection page, you can view the resource usage of the system memory, CPU, and flash space.

### NOTE

Path: **Maintenance > Damage Detection**

# 7 App Operations

---

You can commission the SmartMGC using the FusionSolar app or SUN2000 app. For details, see the *FusionSolar App and SUN2000 App Device Commissioning Guide (SmartLogger5000 & SmartMGC5000)*.

# 8 Maintenance

---

## 8.1 Routine Maintenance

To ensure that the device operates properly for a long term, you are advised to perform routine maintenance as described in this section.

---

 **DANGER**

Before cleaning the device, connecting cables, and checking the grounding reliability, ensure that the device and its upstream and downstream switches have been turned off.

---

**Table 8-1** Maintenance checklist

Check Item	Check Method	Maintenance Interval
Alarm	View alarms on the app, SmartMGC, or management system.	Routine maintenance
Device cleaning	Check whether the SmartMGC is dirty.	Depending on the actual situation
Running status	<ul style="list-style-type: none"><li>• Check whether the SmartMGC is damaged or deformed.</li><li>• Check whether the SmartMGC generates abnormal sound during operation.</li></ul>	Once a year
Electrical connection	<ul style="list-style-type: none"><li>• Check whether cables are disconnected or loose.</li><li>• Check whether cables are damaged, especially whether the cable sheath that contacts a metal surface is damaged.</li></ul>	Once a year
Grounding reliability	Check whether the ground terminal and ground cable are securely connected.	Once a year

** NOTE**

If a fault that affects the device operation is detected during routine maintenance and cannot be rectified, contact technical support engineers.

## 8.2 Troubleshooting

**Table 8-2** Troubleshooting

No.	Symptom	Possible Cause	Suggestion
1	The device cannot be powered on.	<ol style="list-style-type: none"><li>1. The power adapter is faulty or is not properly connected to the power port (GND 12 V) of the SmartMGC.</li><li>2. The DC power supply is not properly connected to the power port (DC IN 12/24V or DC OUT 12V/1A) of the SmartMGC, or the cable is loose, disconnected, or connected in reverse polarity.</li><li>3. The SmartMGC is faulty.</li></ol>	<ol style="list-style-type: none"><li>1. Replace the power adapter or check that the power adapter is properly connected to the power port (GND 12V) of the SmartMGC.</li><li>2. Check that the DC power supply is properly connected to the power port (DC IN 12/24V or DC OUT 12V/1A) of the SmartMGC. If the cable is loose, disconnected, or connected in reverse polarity, reconnect the cable.</li><li>3. Contact your vendor or Huawei technical support.</li></ol>

No.	Symptom	Possible Cause	Suggestion
2	Some devices cannot be found or failed to be added.	<ol style="list-style-type: none"><li data-bbox="715 297 1054 533">1. The ports are not properly connected to the devices, or the cables are loose, disconnected, or connected in reverse polarity.</li><li data-bbox="715 544 1054 645">2. Communications parameters are incorrectly set.</li><li data-bbox="715 656 1054 857">3. The devices that cannot be detected automatically, such as the EMI and power meter, are not manually added.</li><li data-bbox="715 869 1054 936">4. There are devices with duplicate addresses.</li></ol>	<ol style="list-style-type: none"><li data-bbox="1086 297 1426 667">1. Check whether the ports are properly connected to the devices. Check the communications cable connections. If the cables are loose, disconnected, or connected in reverse polarity, reconnect the cables.</li><li data-bbox="1086 678 1426 813">2. Check whether the communications parameters are correctly set.</li><li data-bbox="1086 824 1426 992">3. Manually add devices that cannot be detected automatically, such as the EMI and power meter.</li><li data-bbox="1086 1003 1426 1171">4. Check the addresses of all devices and ensure that the addresses are unique. Then, start device search again.</li><li data-bbox="1086 1182 1426 1281">5. Contact your vendor or Huawei technical support.</li></ol>

No.	Symptom	Possible Cause	Suggestion
3	MBUS networking failed.	<ol style="list-style-type: none"> <li>1. The inverter or SmartMGC does not support MBUS.</li> <li>2. The AC power cable is loose, disconnected, or in an incorrect phase sequence.</li> <li>3. The upstream switch for the AC power cable is not turned on.</li> <li>4. <b>Built-in MBUS or Networking</b> is set to <b>Disable</b>.</li> <li>5. The anti-crosstalk function is enabled, but the inverter is not added to the whitelist (SN list).</li> <li>6. The SmartMGC is faulty.</li> </ol>	<ol style="list-style-type: none"> <li>1. Check whether the inverter and SmartMGC support MBUS.</li> <li>2. Check the AC power cable. Reconnect the cable if it is loose, disconnected, or in an incorrect phase sequence.</li> <li>3. Check that the upstream switch for the AC power cable is turned on.</li> <li>4. Set <b>Built-in MBUS</b> and <b>Networking</b> to <b>Enable</b>.</li> <li>5. Check that the inverter is added to the whitelist.</li> <li>6. Contact your vendor or Huawei technical support.</li> </ol>
4	A device is disconnected or failed to communicate.	<ol style="list-style-type: none"> <li>1. The device has been powered off.</li> <li>2. The device has been replaced.</li> <li>3. The device has been removed.</li> <li>4. The communication parameters (such as the baud rate or address) of the device have been changed.</li> <li>5. The communications cable between the device and the SmartMGC is loose or disconnected.</li> </ol>	<ol style="list-style-type: none"> <li>1. Check the communications cable and network cable connections between the device and the SmartMGC. If the cables are loose or disconnected, reconnect them securely.</li> <li>2. Check the device connection and power on the device.</li> <li>3. Check whether the communications parameters of the device are correctly set.</li> <li>4. If the device has been replaced, perform device search again or manually add the device.</li> <li>5. If the device has been removed, delete it from <b>Device Management</b>.</li> </ol>

No.	Symptom	Possible Cause	Suggestion
5	Communication with the management system failed. [1]	<ol style="list-style-type: none"><li>1. The SmartMGC is not connected to the PC, or the cable is loose or disconnected.</li><li>2. The parameters of the wired or wireless network are incorrectly set.</li><li>3. The management system parameters are incorrectly set.</li></ol>	<ol style="list-style-type: none"><li>1. Check that the Ethernet port of the SmartMGC is correctly connected to the PC or router.</li><li>2. Check that the parameters of the wired or wireless network are correctly set.</li><li>3. Check that the management system parameters are correctly set.</li></ol>
6	The 4G communication is abnormal.	<ol style="list-style-type: none"><li>1. The SIM card is not inserted or it is in arrears or damaged.</li><li>2. The 4G antenna is not tightened or is damaged.</li><li>3. The management system parameters and wireless network parameters are incorrectly set.</li><li>4. SIM card registration failed.</li></ol>	<ol style="list-style-type: none"><li>1. Insert or replace the SIM card.</li><li>2. Tighten or replace the 4G antenna.</li><li>3. Check that the management system parameters and wireless network parameters are set correctly.</li><li>4. Contact the SIM card carrier or Huawei technical support.</li></ol>

[1]: Refer to [Table 6-88](#) to rectify the fault based on the connection status between the SmartMGC and the management system.

## 8.3 Alarm List

For details about alarms, see [SmartLogger and SmartMGC Alarm Reference](#).

## 8.4 Device Replacement

### NOTICE

User information on the old device cannot be migrated to the new device. The administrator needs to add the user information on the new device.

---

 **CAUTION**

If the SmartMGC enclosure is hot, there is a risk of scalding. Wait until it has cooled down before performing the next step.

---

---

 **DANGER**

- Ensure that the secondary side has no open circuit for the the CT in operation and no short circuit for the PT in operation. Otherwise, overcurrent or high voltage may occur, which may cause equipment damage and personal injury or even death.
  - When connecting a high-voltage cable, ensure that the cores are completely inserted into the terminals. Any exposed core will cause fatal hazards.
  - Before removing or connecting a current detection signal cable, power off the primary circuit of the CT.
- 

- Step 1** Choose **Maintenance > System Maintenance > Migrate Data**. The dialog box for data migration is displayed.
- Step 2** Select **Export Configuration Data** and enter the encryption password of the configuration file to be exported and the login password (for confirmation) to export the configuration data.
- Step 3** Turn off the upstream and downstream switches of the SmartMGC, disconnect the cables from the SmartMGC, and mark the cables.
- Step 4** Remove the SmartMGC and install a new SmartMGC.
- Step 5** Reconnect the cables to the new SmartMGC based on the cable labels. Turn on the upstream and downstream switches of the SmartMGC.
- Step 6** Log in to the WebUI again and choose **Maintenance > System Maintenance > Migrate Data**. The dialog box for data migration is displayed.
- Step 7** Select **Import Configuration Data**, import the configuration data package, and enter the file decryption password (the file encryption password in step 2) to import the configuration data.
- Step 8** Restart the SmartMGC for the configuration file to take effect.

----End

## 8.5 Device Disposal

If the SmartMGC reaches the end of its service life, dispose of it in accordance with local regulations for the disposal of electrical equipment.

# 9 FAQs

---

## 9.1 How Do I Calculate the Monthly Data Usage of a SIM Card?

Monthly data plan of the SIM card  $\geq$  Monthly data of the inverters + Monthly data of the EMIs + Monthly data of the optimizers + Monthly data of the ESSs + Monthly data of the power meters. If other devices are connected to the SmartMGC in the network, the monthly data plan of the SIM card needs to be increased as required.

---

### NOTICE

To ensure normal device operation, you need to set the domain name of the management system in the SIM card whitelist (add the domain name to the carrier whitelist). If the setting is incorrect, the device functions may be restricted or the communication may fail.

---

**Table 9-1** Recommended SIM card data plan

Management System	Recommended Monthly SIM Card Data Plan		Data Baseline	
FusionSolar SmartPV MS	Inverter	15 MB + 16 MB x Number of inverters	<ul style="list-style-type: none"> <li>• Device performance data can be updated every 5 minutes.</li> <li>• Logs of the inverters, ESSs, and I-V diagnosis can be exported monthly.</li> <li>• Inverters and ESSs can be upgraded once a month. If the SmartMGC needs to be upgraded once a month, 80 MB more data is required.</li> </ul>	
	EMI	3 MB x Number of EMIs		
	Optimizer	<ul style="list-style-type: none"> <li>• Supports optimizer data compression<sup>[1]</sup>: 2 MB + 0.1 MB x Number of optimizers</li> <li>• Does not support optimizer data compression: 2 MB + 0.3 MB x Number of optimizers</li> </ul>		
	Power meter			3 MB x Number of power meters
	ESS model	LUNA2000-107-1S11		80 MB + 120 MB x Number of ESSs
		LUNA2000-161-2S11		80 MB + 120 MB x Number of ESSs
		LUNA2000-215-2S10		80 MB + 120 MB x Number of ESSs
		LUNA2000-215-2S11		80 MB + 120 MB x Number of ESSs
LUNA2000-215-2S12		80 MB + 120 MB x Number of ESSs		
<p>[1]: The inverters of the following models and software versions support optimizer data compression:</p> <ul style="list-style-type: none"> <li>• All software versions of the SUN2000-(30K, 40K, 50K)-MC0</li> <li>• SUN2000MG V600R023C10SPC110 and later versions of the SUN5000-(150K-MG0-ZH, 150K-MG0)</li> </ul>				

## 9.2 How Do I Identify the Meter Wiring Direction?

**Table 9-2** Determining the meter wiring direction

Positive/ Negative	Description
Positive	When the array feeds power to the power grid, the active power of the meter is a negative value. When the array draws electricity from the grid, the active power of the meter is a positive value.
Negative	When the array feeds power to the power grid, the active power of the meter is a positive value. When the array draws electricity from the grid, the active power of the meter is a negative value. Reverse wiring may exist.

## 9.3 What Types of Power Meters Can Be Connected?

**Table 9-3** Supported power meters

Vendor	Model	Limited Feed-in
ABB	A44	-
Acrel	PZ96L	-
Algodue	UPM209	-
CHINT	DDSU666-H	-
CHINT	DTSU666	-
CHINT	DTSU666-H	Supported <sup>[1]</sup>
CHINT	DTSU666-HW	Supported <sup>[1]</sup>
Elster	A1800ALPHA	-
GAVAZZI	EM210	-
Janitza	UMG103-CBM	-
Janitza	UMG104	-
Janitza	UMG604	-
Janitza	UMG96-S2	-
Lead	LD-C83	-
Linyang	DDSU71	-
Linyang	DTSU71	Supported <sup>[1]</sup>

Vendor	Model	Limited Feed-in
Linyang	DTSU71C	Supported <sup>[1]</sup>
MingHua	CRDM-830	-
Mitsubishi	EMU4-BD1-MB	-
Mitsubishi	M8FM-N3LTR	-
Mitsubishi	ME110SR-MB	-
Mitsubishi	ME110SSR-MB	-
Mitsubishi	ME110NSR-MB	-
Mitsubishi	ME110SSR-4APH	-
NARUN	PD510	-
NetBiter	CEWE	-
People	RM858E	-
REAL ENERGY SYSTEM	PRISMA-310A	-
Rishabh	LM1360	-
Schneider	PM1200	-
Schneider	PM2xxx	-
Schneider	PM5100	-
Schneider	PM5300	-
SFERE	PD194Z	-
Socomec	COUNTIS-E43	-
Toshiba	S2MS	-
Wave Energy	PWM-72	-
WEG	MMW03-M22CH	-
YADA	YDS60-80	-
YADA	YDS60-C24	Supported <sup>[1]</sup>
YADA	YDS70-C16	-
Wisdom	DDSU1079-CT	-
Wisdom	DHSU1079-CT	Supported <sup>[1]</sup>
Wisdom	DHSU1079-ZT	Supported <sup>[1]</sup>
[1]: Applicable only to three-phase power scenarios.		

## 9.4 What Types of EMIs Can be Connected?

**Table 9-4** Supported EMIs

Vendor	Model	EMI Signal
ABB	VSN800-12	Total irradiance, ambient temperature, and PV module temperature
	VSN800-14	Total irradiance, ambient temperature, PV module temperature, wind direction, and wind speed
Gill MetPak Pro	Gill MetPak Pro	Total irradiance, ambient temperature, PV module temperature, wind direction, and wind speed
Hukseflux SRx	Hukseflux SRx	Total irradiance and ambient temperature
Ingenieurbüro Si-RS485TC	Ingenieurbüro Si-RS485TC	Total irradiance, ambient temperature, PV module temperature, and wind speed
Kipp&Zonen	SMPx series	Total irradiance and ambient temperature
Lufft	WSx-UMB	Total irradiance, ambient temperature, wind direction, and wind speed
	WSx-UMB (external sensors)	Total irradiance, ambient temperature, PV module temperature, wind direction, and wind speed
Meier-NT ADL-SR	Meier-NT ADL-SR	Total irradiance, ambient temperature, PV module temperature, and wind speed
MeteoControl	SR20-D2	Total irradiance and ambient temperature

Vendor	Model	EMI Signal
RainWise	PVmet-150	Total irradiance, ambient temperature, and PV module temperature
	PVmet-200	Total irradiance, ambient temperature, PV module temperature, wind direction, and wind speed
Soluzione Solare	SunMeter	Total irradiance and ambient temperature
Jinzhou Solargiga	PC-4 (V2.11)	Total irradiance, ambient temperature, PV module temperature, wind direction, and wind speed
Sensor ADAM <sup>[1]</sup>	-	-
[1]: The sensor-type EMI (current-type or voltage-type) communicates with the SmartMGC through the ADAM analog-to-digital converter.		

## 9.5 What Standards Must 4G Antennas Prepared by Customers Meet?

Table 9-5 4G antenna

Item	Specifications
Frequency range (MHz)	700-960/1710-2690
Voltage standing wave ratio	<ul style="list-style-type: none"> <li>• 700-960 ≤ 3.5</li> <li>• 1710-2690 ≤ 3</li> </ul>
Input impedance	50 Ω
Horizontal gain (dBi)	> -1
Polarization	Vertical
Connector	SMA-J

# 10 Technical Specifications

## General Specifications

Item	SmartMGC
Power consumption	12.5 W (typical), 16.5 W (maximum)
Net weight	2.58 kg
Operating temperature	-40°C to +60°C
Storage temperature	-40°C to +70°C
Relative humidity	5%–95% RH (non-condensing)
IP rating	IP20
Installation mode	Installed using screws or on a guide rail
Pollution degree	2
Corrosion level	B1
Maximum operating altitude	5000 m
Dimensions (W x H x D)	<ul style="list-style-type: none"><li>• Including mounting ears: 279 mm x 160 mm x 59 mm</li><li>• Excluding mounting ears: 225 mm x 160 mm x 44 mm</li></ul>
Power adapter	<ul style="list-style-type: none"><li>• AC input: 100–240 V, 50 Hz/60 Hz</li><li>• DC output: 12 V/2 A</li></ul>

## Device Management

Item	SmartMGC
Communications mode	RS485, ETH, MBUS (optional), 4G (optional), SFP (optional)
Maximum communication distance	<ul style="list-style-type: none"> <li>● RS485: 1000 m</li> <li>● ETH: 100 m</li> <li>● MBUS: 500 m (multi-core cable)</li> <li>● Optical fiber (single-mode, 1310 nm optical module)                             <ul style="list-style-type: none"> <li>- Optional 1000M optical module: 10000 m</li> <li>- Optional 100M optical module: 12000 m</li> </ul> </li> </ul>
Number of connected inverters	A maximum of 80 inverters can be connected.

## Port Specifications

Item	SmartMGC
Ethernet port (WAN/LAN/GE)	10M/100M/1000M autonegotiation
Optical fiber port (SFP)	A 100M/1000M SFP optical module can be connected.
MBUS port (MBUS)	Supports max. 1000 V AC.
RS485 port (COM)	Supported baud rates: 1200 bit/s, 2400 bit/s, 4800 bit/s, 9600 bit/s, 19200 bit/s, and 115200 bit/s
USB port (USB)	USB2.0
Fan port (FAN)	12 V DC
Active/Standby DI/DO port (DI DO)	Communication between active and standby modules
Digital input port (DI)	Supports passive dry contact signals.
Digital output port (DO)	<ul style="list-style-type: none"> <li>● Supports relay dry contact signal output (NO and NC contacts).</li> <li>● Supports the 12 V DC signal voltage.</li> </ul>
Analog input port (AI/DI)	<ul style="list-style-type: none"> <li>● AI1: 0–10 V input</li> <li>● AI2–AI4: 4–20 mA, 0–20 mA</li> </ul>
Power port (GND 12V)	12 V DC/0.1 A output

Item	SmartMGC
Power port (DC IN 12/24 V or DC OUT 12 V/1 A)	<ul style="list-style-type: none"> <li>12 V/24 V DC input</li> <li>12 V DC/1 A output</li> </ul>
4G antenna port (4G)	SMA-K (external screw, inner hole) port, used with an antenna that has the SMA-J (internal screw, inner pin) port
SIM card slot (Mini SIM)	Supports standard industrial SIM cards (size: 25 mm x 15 mm; capacity: $\geq$ 64 KB).
Current detection port (I_AC)	Detects three routes of current in one group; connects to the secondary side with the rated current of 5 A of a current transformer.
Voltage detection port (U_AC)	Detects three routes of voltage in two groups; connects to a potential transformer (with a rated voltage of 100 V on the secondary side) or directly connects to a voltage (U <sub>an</sub> /U <sub>bn</sub> /U <sub>cn</sub> : 57.7–277 V; U <sub>ab</sub> /U <sub>bc</sub> /U <sub>ac</sub> : 100–480 V).
High-voltage DI port [DI (HV)]	<ul style="list-style-type: none"> <li>AC: 100–277 V</li> <li>DC: 110 V/220 V</li> </ul>
High-voltage DO port [DO (HV)]	<ul style="list-style-type: none"> <li>1–7: AC 100–277 V, DC: 12–30 V</li> <li>8: DC 12–220 V</li> </ul>

## Wireless Communication

Item	SmartMGC5000B04NH/SmartMGC5000B06GL
4G/3G/2G	<ul style="list-style-type: none"> <li>LTE FDD: B1/B2/B3/B4/B5/B7/B8/B18/B19/B20/B26/B28/B66</li> <li>LTE TDD: B38/B40/B41</li> <li>WCDMA: B1/B5/B8</li> <li>GSM: B3/B5/B8</li> </ul>
WLAN	2.4G

## 4G Module Radio Frequency Bands

Frequency Band	Tx	Rx
WCDMA Band 1	1920–1980 MHz	2110– 2170 MHz
WCDMA Band 5	824–849 MHz	869–894 MHz
WCDMA Band 8	880–915 MHz	925–960 MHz

Frequency Band	Tx	Rx
GSM 850	824–849 MHz	869–894 MHz
GSM 900	880–915 MHz	925–960 MHz
GSM 1800	1710–1785 MHz	1805–1880 MHz
LTE Band 1	1920–1980 MHz	2110– 2170 MHz
LTE Band 2	1850–1910 MHz	1930–1990 MHz
LTE Band 3	1710–1785 MHz	1805–1880 MHz
LTE Band 4	1710–1755 MHz	2110–2155 MHz
LTE Band 5	824–849 MHz	869–894 MHz
LTE Band 7	2500–2570 MHz	2620–2690 MHz
LTE Band 8	880–915 MHz	925–960 MHz
LTE Band 18	815–830 MHz	860–875 MHz
LTE Band 19	830–845 MHz	875–890 MHz
LTE Band 20	832–862 MHz	791–821 MHz
LTE Band 26	703–748 MHz	758–803 MHz
LTE Band 28	2500–2570 MHz	2620–2690 MHz
LTE Band 38	2570–2620 MHz	2570–2620 MHz
LTE Band 40	2300–2400 MHz	2300–2400 MHz
LTE Band 41	2496–2690 MHz	2496–2690 MHz
LTE Band 66	1710–1780 MHz	2110–2180 MHz

## 4G Module Transmit Power

Frequency Band	Standard Value (Unit: dBm)	Remarks (Unit: dB)
GSM 850	33	±2
GSM 900	33	±2
GSM 1800	30	±2
WCDMA Band 1	23	+1/-3
WCDMA Band 5	23	+1/-3
WCDMA Band 8	23	+1/-3
LTE Band 1	23	±2

Frequency Band	Standard Value (Unit: dBm)	Remarks (Unit: dB)
LTE Band 2	23	±2
LTE Band 3	23	±2
LTE Band 4	23	±2
LTE Band 5	23	±2
LTE Band 7	23	±2
LTE Band 8	23	±2
LTE Band 18	23	±2
LTE Band 19	23	±2
LTE Band 20	23	±2
LTE Band 26	23	±2
LTE Band 28	23	±2
LTE Band 38	23	±2
LTE Band 40	23	±2
LTE Band 41	23	±2
LTE Band 66	23	±2

## WLAN

Item	SmartMGC
Frequency band	2.4 GHz: 2.4–2.4835 GHz
Gain	2.4 GHz: 2.85 dBi
Transmit power	2.4 GHz: 1 x 100 mW
Maximum throughput	2.4 GHz: 65 Mbit/s
Single/Dual-band mode	Single-band mode
MIMO	2.4 GHz: 1T1R
Polarization mode	Linear
Directivity	All-around
Protocols and standards	802.11b/g/n/ax
Bandwidth	≤ 40 MHz
Maximum transmit power	≤ 20 dBm E.I.R.P.

# A Port Numbers

Table A-1 Port numbers

<b>Source Device</b>	SmartMGC		
<b>Source IP Address</b>	WAN IP address		
<b>Source Port</b>	Dynamic allocation		
<b>Destination Device</b>	SmartPVMS		
<b>Destination IP Address</b>	SmartPVMS IP address		
<b>Destination Port (Listening)</b>	2121–2130	<ul style="list-style-type: none"><li>• 10000–20000</li><li>• 35000–50000</li></ul>	27250
<b>Protocol</b>	FTPS	FTPS	Modbus-TCP
<b>Port Description</b>	The SmartMGC, functioning as a client, connects to the FTP server of the management system (SmartPVMS). This channel is used for command transmission and is disabled by default.	The SmartMGC, functioning as a client, connects to the FTP server of the management system (SmartPVMS). This channel is used for data and file transmission and is disabled by default.	The SmartMGC, functioning as a client, connects to the management system (SmartPVMS) to query data and set parameters over Modbus. This function is disabled by default.

 NOTE

- If a third-party management system connects to the SmartMGC over Modbus TCP, the commonly used port of the SmartMGC is 502, which is used to query and set data between the SmartMGC and the third-party management system.
- If a third-party management system connects to the SmartMGC over IEC 104, the commonly used port of the SmartMGC is 2404 by default, which is used to query and set data between the SmartMGC and the third-party management system.
- If the SmartMGC connects to a third-party FTP server over FTP, the common port number is 21, which is used to periodically upload performance data to the third-party FTP server.
- If the SmartMGC connects to a third-party email server over SMTP, the common port number is 25, 465, or 587, which is used to send emails to the email server.
- If the SmartMGC connects to a third-party NTP server over NTP, the common port number is 123, which is used for time synchronization with the NTP server.
- If the SmartMGC connects to a remote output server of Japan Electric Power Company over HTTPS, the common port number is 443, which is used to synchronize the scheduling table with the electric power company.

# B Management System Domain Names

---

For details about management system domain names, see **Domain Name List of Management Systems** in the [FusionSolar App User Manual](#).

# C Certificate Management and Maintenance

## C.1 Initial Certificate Risk Disclaimer

The Huawei-issued certificates preconfigured on Huawei devices during manufacturing are mandatory identity credentials for Huawei devices. The disclaimer statements for using the certificates are as follows:

- Initial certificates are used only in the deployment phase, for establishing initial security channels between devices and the customer's network. Huawei does not promise or guarantee the security of the initial certificates.
- Customers shall bear consequences of all security risks and security incidents arising from using initial certificates as service certificates.
- Initial certificates are valid from the manufacturing date until December, 2099.
- You are advised not to use the initial certificates in other service scenarios except for logging in to the device through the local WebUI.
- Services using an initial certificate will be interrupted when the certificate expires.
- It is recommended that customers deploy a PKI system to issue certificates for devices and software on the live network and manage the lifecycle of the certificates. To ensure security, certificates with short validity periods are recommended.

## C.2 Application Scenarios of Initial Certificates

Table C-1 Initial certificates

Certificate Path	Certificate Name	Description
/app_run/app_bin/ bin_arm/webpage/certs	<ul style="list-style-type: none"><li>• server.crt</li><li>• server.my.pem</li></ul>	Web certificate.

Certificate Path	Certificate Name	Description
/mnt/sub_bin0/default_certs	<ul style="list-style-type: none"> <li>• cert_key_file_old.ema p</li> <li>• cert_encrypted_data_f ile_old.emap</li> <li>• cert_key_file.emap</li> <li>• cert_encrypted_data_f ile.emap</li> </ul>	Default port password and certificate.
/mnt/sub_bin0/default_certs/app_cert	<ul style="list-style-type: none"> <li>• ca.crt</li> <li>• tomcat_client.crt</li> <li>• tomcat_client.my</li> </ul>	Certificate for connecting to a mobile app as the server.
/mnt/sub_bin0/default_certs/south_cert	<ul style="list-style-type: none"> <li>• ca.crt</li> <li>• tomcat_client.crt</li> <li>• tomcat_client.my</li> </ul>	Certificate for connecting to a southbound device as the server.
/mnt/sub_bin0/default_certs/sppc_cert	<ul style="list-style-type: none"> <li>• ca.crt</li> <li>• tomcat_client.crt</li> <li>• tomcat_client.my</li> </ul>	Certificate for connecting to the SPPC as a client.
/mnt/sub_bin0/default_certs/pvms_cert	<ul style="list-style-type: none"> <li>• ca.crt</li> <li>• tomcat_client.crt</li> <li>• tomcat_client.my</li> </ul>	Certificate for connecting to a Huawei-developed management system as a client.
/mnt/sub_bin0/default_certs/pvms1_cert	<ul style="list-style-type: none"> <li>• ca.crt</li> <li>• tomcat_client.crt</li> <li>• tomcat_client.my</li> </ul>	Password and certificate for connecting to a third-party management system as a client.

 **NOTE**

For details about how to replace a certificate, contact technical support engineers to obtain the corresponding security maintenance manual.

# D Contact Information

---

If you have any questions about this product, please contact us.



<https://digitalpower.huawei.com>

Path: **About Us > Contact Us > Service Hotlines**

To ensure faster and better services, we kindly request your assistance in providing the following information:

- Model
- Serial number (SN)
- Software version
- Alarm ID or name
- Brief description of the fault symptom

 **NOTE**

EU Representative Information: Huawei Technologies Hungary Kft.

Add.: HU-1133 Budapest, Váci út 116-118., 1. Building, 6. floor.

Email: [hungary.reception@huawei.com](mailto:hungary.reception@huawei.com)

# E Digital Power Customer Service

---



<https://digitalpower.huawei.com/robotchat/>

---

# F Acronyms and Abbreviations

---

## A

**AC** alternating current

**AI** analog input

**ALM** alarm

## C

**CT** current transformer

**COM** communication

## D

**DC** direct current

**DI** digital input

**DO** digital output

## E

**EMI** environmental monitoring  
instrument

**ETH** Ethernet

**G**

**GE** gigabit Ethernet

**GND** ground

**L**

**LAN** local area network

**LED** light-emitting diode

**M**

**MBUS** monitoring bus

**N**

**NC** normally closed

**NO** normally open

**P**

**PT** potential transformer

**POE** power over Ethernet

**R**

**RST** reset

**RSTP** Rapid Spanning Tree  
Protocol

**S**

<b>SFP</b>	Small Form-factor Pluggable
<b>STP</b>	Spanning Tree Protocol
<b>SOC</b>	state of charge
<b>SOH</b>	state of health
<b>T</b>	
<b>TLS</b>	Transport Layer Security
<b>U</b>	
<b>USB</b>	Universal Serial Bus
<b>W</b>	
<b>WAN</b>	wide area network
<b>WLAN</b>	wireless local area network