



P3 Pro Series Storage Inverter

P3-Pro-15.0

P3-Pro-20.0

P3-Pro-25.0

P3-Pro-30.0

Copyright © FOXESS Co., Ltd. All rights reserved.

No part of this document may be reproduced, copied, or distributed in any form or by any means without prior written authorization from the company.

Trademarks



and other Fox ESS trademarks are the property of FOXESS Co., Ltd.

All other trademarks or registered trademarks mentioned in this document belong to their respective owners.

Software License

Commercial use of any part or all of the firmware or software developed by the company is strictly prohibited.

Reverse engineering, decompilation, or any other actions that destroy the original design of the company's software are prohibited.

This document is intended as a usage guide only. All statements, information, and recommendations herein do not constitute any warranty, express or implied.

Due to product version updates or other reasons, the content of this document may be updated periodically. Please download the latest version from the official website if needed.

FOXESS Co., Ltd

Add:

No.939, Jinhai Third Road, New Airport Industry Area, Longwan District, Wenzhou, Zhejiang, China

Tel: 0510- 68092998

Postcode: 325024

WWW.FOX-ESS.COM

Version V1.0.0

Date 2025-09

Contents

1	Notes on This Manual	1
1.1	Scope of Validity	1
1.2	Target Group	1
1.3	Symbols Used	1
2	Safety Precautions	5
2.1	Personnel Safety	5
2.2	Electrical connection safety	6
2.3	Installation Requirements	8
2.4	PE Connection and Leakage Current	9
3	Product Introduction	11
3.1	Basic Features	11
3.2	Dimensions	15
3.3	Terminals of inverter	15
4	Technical Data	16
4.1	PV Input (For P3 Pro Only)	16
4.2	Battery	16
4.3	AC Output/Input	17
4.4	EPS Output	17
4.5	Efficiency and Protection	18
4.6	General Data	19
5	Installation	20
5.1	Check for Physical Damage	20
5.2	Unpackaging	20
5.3	Installation Requirements	22
5.4	Tools Preparation	25
5.5	Inverter Handling	25
5.6	Installation Steps	26
6	Electrical Connection	29
6.1	Circuit Overview	29
6.2	PV Connection (For P3-Pro Only)	30
6.3	Battery Connection	33
6.4	Grid Connection	35

6.5 Earth Connection	41
6.6 Communication Connection	42
6.7 EPS Connection (Non-parallel State)	52
6.8 System Connection Diagrams	53
6.9 Inverter Start-Up	54
6.10 Inverter Switch Off	54
7 Main function implementation	55
7.1 Parallel system wiring and setting	55
7.2 Drm wiring	65
7.3 RCR wiring	66
7.4 SG ready wiring and setting	67
7.5 Reactive Function Setting	69
7.6 DieselGen	73
7.7 EPS Wiring	78
7.8 Unbalanced Load	79
8 Firmware Upgrading	80
9 Operation	85
9.1 Control Panel	85
9.2 Function Tree	86
10 Maintenance	87
10.1 Alarm List	87
10.2 Troubleshooting and Routine Maintenance	92
11 Decommissioning	93
11.1 Disassembling the Inverter	93
11.2 Storing the Inverter	93
11.3 Transporting the Inverter	93
11.4 Decommissioning/Scrapping the Inverter	93
12 Appendix	94
12.1 Quality Guarantee	94
12.2 Contact Us	95

1 Notes on This Manual

P3 Pro series inverters are designed and tested in accordance with international safety requirements. Certain safety precautions must be taken when installing and operating this inverter. The installer must read and follow all instructions, cautions and warnings in this installation manual.

1.1 Scope of Validity

This manual describes the assembly, installation, commissioning, maintenance and troubleshooting of the following model (s) of products:

P3-Pro-15.0 P3-Pro-20.0 P3-Pro-25.0 P3-Pro-30.0

Please keep this manual where it will be accessible at all times.

1.2 Target Group

This manual is intended for use by qualified electricians only. All procedures described herein shall be performed by trained and experienced electrical personnel in compliance with basic electrical safety requirements.

1.3 Symbols Used

The following symbols are used in the manual to highlight information in order to ensure the safety of the user's person and property when using the product, and to use the product more efficiently and optimally. The following symbols may appear in this manual, and the meanings they represent are listed below:

Danger!

"Danger" indicates a hazardous situation which, if not avoided, will result in death or serious injury.

Warning!

"Warning" indicates a hazardous situation which, if not avoided, could result in minor or moderate injury.

Note!

"Note" provides important tips and guidance.

Danger!

The PV string will generate lethal high voltage when exposed to sunlight.

Operators must wear proper personal protective equipment during electrical

connections.

Must ensure that cables are voltage-free with a measuring instrument before touching Dc cables.

Respect all safety instructions listed in relevant documents about PV strings.

 Danger!

Before electrical connections, please make sure that the inverter switch and all switches connected to the inverter are set to "OFF", otherwise electric shock may occur!

Ensure that the inverter is undamaged and all cables are voltage free before performing electrical work. Do not close the Ac circuit breaker until the electrical connection is complete.

 Warning!

Damage to the product caused by incorrect wiring is not covered by the warranty.

Electrical connection must be performed by professionals.

Operators must wear proper personal protective equipment during electrical connections.

All cables used in the PV generation system must be firmly attached, properly insulated, and adequately dimensioned.

 Danger!

The PV string will generate lethal high voltage when exposed to sunlight.

Respect all safety instructions listed in relevant documents about PV strings.

 Warning!

Make sure the PV array is well insulated to ground before connecting it to the inverter.

Make sure the maximum DC voltage and the maximum short circuit current of any string never exceed inverter permitted values specified in "Technical Data" Check the positive and negative polarity of the PV strings, and connect the PV connectors to corresponding terminals only after ensuring polarity correctness.

During the installation and operation of the inverter, please ensure that the positive or negative electrodes of PV strings do not short-circuit to the ground. Otherwise, an AC or DC short-circuit may occur, resulting in equipment damage. The damage caused by this is not covered by the warranty.











Electric arc or contactor over-temperature may occur if the PV connectors are not firmly in place, and Fox shall not be held liable for any damage caused.

If the Dc input cables are reversely connected and the Dc switch has been rotated to "ON", do not operate immediately. Otherwise, the inverter may be damaged. Please turn the Dc switch to "OFF" and remove the Dc connector to adjust the polarity of the strings when the string current is lower than 0.5 A.

 **Warning!**

Before connecting the PV array to the inverter, ensure that the impedances between the positive terminals of the PV string and earth, and between the negative terminals of the PV string and earth are larger than 1 M Ohm.

This section explains the symbols shown on the inverter and on the type label:

Symbols	Explanation
	CE mark. The product complies with the relevant EU directives.
	RCM mark.
	RoHS mark.
	Beware of hot surface. The inverter can become hot during operation. Avoid contact during operation.
	Danger of high voltages. Danger to life due to high voltages in the inverter!
	Hazards, warnings and cautions. Important safety information regarding personal safety. Failure to follow the safety information in this manual could result in injury or even death.
	Capacitor discharge. Before opening the cover, the inverter must be disconnected from the grid and the PV string. Wait at least 5 minutes for the storage capacitors to discharge completely.
	Read the manual before performing any operations on the inverter.
	Product should not be disposed as household waste.
	PE conductor terminal.

2 Safety Precautions

2.1 Personnel Safety

Danger!

Operating Requirements

- High voltage exists inside the equipment. Unauthorized removal of necessary protective measures, improper use, and improper installation and operation may cause serious safety hazards, shock hazards, or equipment damage, and the resulting damage to the equipment is not covered by the warranty.
- Do not energize the equipment without completing the installation or without professional confirmation, and strictly prohibit operation with electricity.

Warning!

Operating Requirements

- Always use special insulated tools for wiring operations. Direct contact or contact with other conductors or indirect contact with the power supply equipment through wet objects is prohibited.
- During operation of the equipment, the enclosure temperature is high and there is a risk of burns. Before touching any part of the inverter, make sure that the equipment and its surfaces are at a contact-safe temperature and voltage before proceeding.

Note!

Personnel requirements

- All operations, including transportation, installation, start-up and maintenance, must be performed by qualified and trained personnel.
- Before operating the equipment, be sure to check that it is in proper condition, including, but not limited to, the equipment's parts, safety devices, and meter display.
- If any abnormality is found during operation, do not use the inverter and avoid temporary maintenance of the inverter.
- Special scenario operators, such as electrical operation, high place operation, equipment maintenance operation, etc., must have special operation qualification that meets the requirements of the local country/region, and should comply with local standards and relevant safety codes.
- Strictly follow the safety operation procedures, understand the potential dangers in equipment operation, and take precautions to maximize the safety of themselves and related personnel to prevent accidents caused by improper operation.
- Operators are required to wear appropriate personal protective equipment, including protective clothing, gloves, goggles, and helmets.
- It is strictly prohibited to operate under fatigue, drunkenness, or ill health.
- Take extra care when the inverter is disconnected from the public grid, as certain components may hold a certain voltage, creating a risk of electric shock.
- Before installation, check the machine to make sure that it does not have any damage caused by transportation or handling processes that could affect the insulation or safety distances. Choose the installation location carefully and observe

the specified cooling requirements.

- Before connecting the inverter to the distribution grid, contact the local distribution grid company for approval. This connection must be carried out by a qualified technician.
- Do not use the equipment when the safety devices do not work or are disabled.
- The manufacturer needs to be notified of any non-standard installation conditions.
- All repairs should be carried out only with approved spare parts, which must be installed in accordance with their purpose and by an authorized contractor or an authorized service representative.

2.2 Electrical connection safety

Danger!

Operating Requirements

- Remove all electrical connections from the unit before making electrical connections.
- Before making electrical connections, it is important to verify that the equipment itself and its front and rear switches are disconnected and that reliable locking and marking measures are in place to prevent accidental energization.

Wiring Requirements

- No loads may be connected between the inverter and its directly connected AC circuit breaker.
- Use test equipment to ensure that the PV strings have the correct positive and negative terminals.
- The entire grounding system should remain intact, including the grounding electrode, grounding trunk, branch wires, and connections to the equipment.

Grounding Requirements

- The protective earth conductor needs to remain grounded during installation and when removing the equipment.

Maintenance Requirements

- High voltage exists inside the unit, do not open the unit's mainframe panel.
- Disconnect the corresponding output switch of the power supply unit before performing maintenance on the power supply unit's back-end electricity or power distribution equipment.

Warning!

Wiring Requirements

- In electrical installations, it is important to follow the relevant codes and standards and to use circuit breakers of appropriate specifications to protect the safety of the circuit.

Grounding Requirements

- The grounding resistance should be in accordance with relevant standards and regulations to ensure effective current discharge. Normally, the value of grounding resistance should be small enough to ensure that the current can be quickly directed to earth in the event of a fault.

Maintenance Requirements

- Always use measuring equipment to ensure that the equipment is at contact-safe temperatures and voltages before touching any parts, and wear protective equipment for operation and maintenance of the inverter.

Note!

Wiring Requirements

- Wires should be secured and supported at appropriate locations to prevent dislodgement or damage due to self-weight or external forces.

Inspection before connection

- Check the appearance and structure of the equipment for damage, whether the equipment received and the actual equipment ordered are the same, and contact Fox ESS in case of doubt, connecting damaged equipment can cause the risk of fire and electric shock.

Wiring Requirements

- Cable slots and crossing holes should have no sharp edges and the location of the pipe or crossing holes should be protected to prevent damage to the cables.

- Strictly follow national and industry standards and codes for electrical wiring for construction and installation.
- Verify that tools and test equipment used are functioning properly, calibrated effectively, and meet safety standards, and check and register the number of tools to prevent them from being left inside the equipment.
- Check that markings and labels on wires, terminals and equipment are clear and accurate.
- Check that connecting terminals are well insulated and protected, free from corrosion, deformation or looseness.
- Incorrect wiring operations can cause accidents such as fire or electric shock, and the resulting damage will not be covered by the warranty.
- Wiring should be clearly labeled to facilitate maintenance and troubleshooting.
- Wiring personnel need to wear appropriate personal protective equipment and use professional insulated tools for operation .
- The grounding system should be tested regularly to check the grounding resistance, connection status, etc. Before operating the equipment, ensure that the equipment is reliably grounded, and find and repair any damage or abnormality in time.
- Cabling should be kept at a safe distance of at least 30mm from high temperature heat sources to prevent aging of the insulation.
- Cables should not block the air inlet and outlet of the equipment.
- After the connection is completed, it should be ensured that the insulation of the wires is restored intact and the exposed conductor parts are effectively insulated.
- The grounded portion should be clearly labeled to alert personnel.
- The grounding connection must be firm and reliable to avoid loose, corrosion, or poor contact. The connection shall be properly treated against corrosion.
- Wiring should be laid neatly and in an orderly manner, avoiding crossings, tangles and excessive bending to minimize the risk of damage to the wires. Select power cords of sufficient length and strictly prohibit making joints or soldering points in power cords.
- The insulation of wires and cables should be intact and have good insulation properties to effectively prevent leakage and short circuit.

- The same kind of cables are tied neatly without outer skin damage, and different kinds of cables are laid out separately, forbidding twisting and crossing.
- Regularly check the system parameters and make records, if anomalies are found, the causes should be identified and dealt with accordingly. If you can not determine the cause of the anomaly, you need to turn to professionals to avoid accidents affecting the use of the system.
- Non-professionals are not allowed to disassemble and overhaul the inverter without authorization, and the operators need to be specially trained.
- Strictly follow the use and maintenance instructions of the product to operate, make sure the warning signs are intact, and replace the signs that become unclear due to long-term use in time.
- Regularly check whether the wiring and connecting terminals of each part of the equipment are firm and whether there is any looseness; especially pay attention to the fan, power module, input terminals, output terminals, grounding, and other parts.
- Place eye-catching warning signs or set up safety warning belts around the products; non-staff are not allowed to enter to avoid mishandling or accidents after unrelated personnel approach the products.
- Hang a "Danger - Do Not Close" tag on the upstream and downstream switches or circuit breakers, and post warning signs to prevent accidental connection.

2.3 Installation Requirements

Danger!

Equipment Protection

- Strictly follow the operation manual and specifications of the equipment to carry out maintenance operations, do not carry out other maintenance operations beyond this manual without authorization to avoid equipment failure due to incorrect operation.
- Prohibit arc welding, drilling, cutting and other operations on the equipment, and prohibit the installation of other equipment on the top of the product.

Drilling Safety

- Avoid pre-buried pipes or lines when drilling to avoid short circuits or other hazards.
- The entire grounding system should be kept intact, including the grounding electrode, grounding trunk, branch lines, and connections to the equipment.
- In electrical installations, it is important to follow the relevant codes and standards and to use circuit breakers of the right size to protect the safety of the circuits.

Note!

Use of Tools

- All tools must be complete, properly certified, and within their inspection validity period. Before use, ensure that the tools are sturdy and free from damage, loose parts, or missing components.

Equipment Protection

- Paint scratches, drops or rust stains that occur during transportation and installation of equipment must be repaired in a timely manner, and long-term exposure of the scratched part may affect the use of the inverter.

Drilling Safety

- Appropriate protective equipment such as goggles, earplugs, helmets, and coveralls should be worn when drilling to prevent splashing debris from hurting eyes and face, reduce noise damage to hearing, and protect the body from injury.
- Cabling should be kept at a safe distance of at least 30 mm from high temperature heat sources to prevent deterioration of the insulation.
- Cables should not block the air inlet or outlet of the equipment.

- Ensure that there is enough space and good lighting, and avoid using tools in dangerous or unstable environments.
- Use the tool correctly and operate the tool correctly according to the instruction manual or professional guidance on the correct way to use the tool.
- Perform regular maintenance, such as cleaning, lubrication, and calibration, to extend the service life of the tools and maintain their performance.
- Before operation, dust, dirt, and debris need to be removed from the surface of the equipment to prevent them from entering the interior of the equipment and causing damage.
- Update the operating system and related software of the equipment in time to fix the loopholes and improve the performance.
- Protect the equipment from external collision and strong vibration.
- Obtain consent from customers and contractors before drilling.
- Check the drilling equipment before use, including whether the drill is securely installed, whether the wires are broken, and whether the switch is normal.
- Ensure that the workpiece being drilled is securely fastened to prevent it from moving or rotating during drilling.
- When replacing drills, cleaning debris or performing equipment maintenance, strictly prevent debris from falling into the interior of the equipment, and be sure to stop the machine first and then clean up the debris in a timely manner.

2.4 PE Connection and Leakage Current

PV System Residual Current Factors

- In every PV installation, several elements contribute to the current leakage to protective earth (PE). these elements can be divided into two main types.
- Capacitive discharge current - Discharge current is generated mainly by the parasitic capacitance of the PV modules to PE. The module type, the environmental conditions (rain, humidity) and even the distance of the modules from the roof can effect the discharge current. Other factors that may contribute to the parasitic capacitance are the inverter's internal capacitance to PE and external protection elements such as lightning protection.
- During operation, the DC bus is connected to the alternating current grid via the inverter. Thus, a portion of the alternating voltage amplitude arrives at the DC bus. The fluctuating voltage constantly changes the charge state of the parasitic PV capacitor (i.e capacitance to PE). This is associated with a displacement current, which is proportional to the capacitance and the applied voltage amplitude.

- Residual current - if there is a fault, such as defective insulation, where an energized cable comes into contact with a grounded person, an additional current flows, known as a residual current.

Residual Current Device (RCMU)

- All inverters incorporate a certified internal RCMU (Residual current monitoring unit) to protect against possible electrocution in case of a malfunction of the PV array, cables or inverter (DC). The RCMU in the inverter can detect leakage on the DC side. There are 2 trip thresholds for the RCMU as required by the DIN VDE 0126-1-1 standard. A low threshold is used to protect against rapid changes in leakage typical of direct contact by people. A higher threshold is used for slowly rising leakage currents, to limit the current in grounding conductors for the safety. The default value for higher speed personal protection is 30mA, and 300mA per unit for lower speed fire safety.

Installation and Selection of an External RCD device

- An external RCD is required in some countries. The installer must check which type of RCD is required by the specific local electric codes. Installation of an RCD must always be conducted in accordance with local codes and standards. recommends the use of a type-A RCD. Unless a lower value is required by the specific local electric codes, suggest choosing a 300mA RCD.
- In installations where the local electric code requires an RCD with a lower leakage setting, the discharge current might result in nuisance tripping of the external RCD. The following steps are recommended to avoid nuisance tripping of the external RCD:
- Selecting the appropriate RCD is important for correct operation of the installation. An RCD with a rating of 30mA may trip at a leakage as 15mA (according to IEC 61008). High quality RCDs will typically trip at a value closer to their rating.

3 Product Introduction

3.1 Basic Features

P3 Pro series are high-quality inverters which can convert solar energy to AC energy and store energy into battery. The inverter can be used to optimize self-consumption, store in the battery for future use or feed-in to public grid. Work mode depends on PV energy and user's preference.

Advantages	
	<ul style="list-style-type: none"> ✓ Advanced DSP control technology. ✓ Utilizes the latest high-efficiency power component. ✓ Advanced anti-islanding solutions. ✓ IP65 protection level. ✓ Max. Efficiency up to 97.8%. EU efficiency up to 97.3%. THD<3%. ✓ Safety & Reliability: Transformerless design with software and hardware protection. ✓ Export limitation (Meter/DRM0/ESTOP). ✓ Power factor regulation. Friendly HMI. ✓ LED status indications. ✓ LCD display technical data, human-machine interaction through four touch keys. ✓ PC remote control.

P3-Pro system diagram for household use

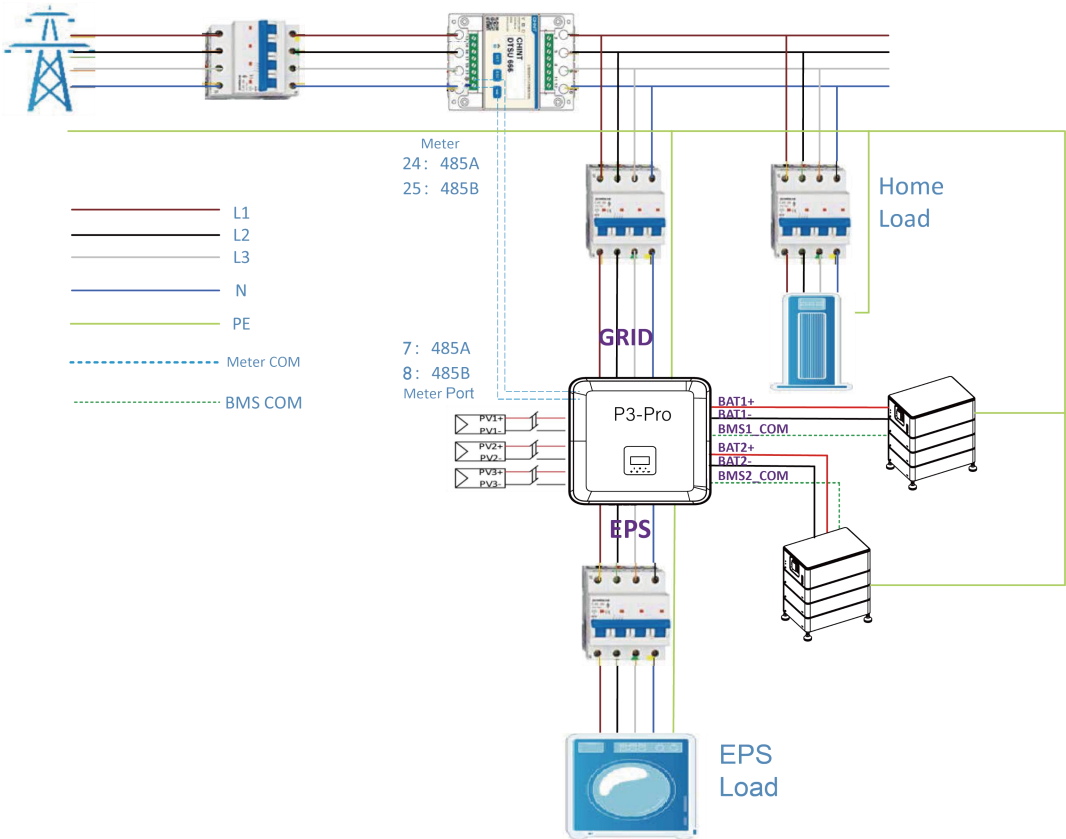

Important: P3-Pro needs to be connected to the 3-phase 5-wire power grid system, and ensure that the GRID is connected to the N line, otherwise the machine will report the SW BUS VOLT fault.

Before installation, use a multimeter to confirm that the positive and negative terminals and voltage are correct. The positive and negative terminals and voltage of the battery are correct. When the battery voltage is between 150V-800V, it can enter the pure off-grid state. When the battery voltage is between 120V-800V, it can enter the grid-connected state.

After installation, you can check the battery voltage of the system through the screen, if the battery voltage is lower than 120V, the battery will not work, and will not be responsible for the damage to the system.

P3-Pro Hybrid Inverters can be used in combination with other generation sources that are synchronized to the utility grid. A second energy meter can be connected to enable the P3-Pro to specifically monitor other generation sources.

Wiring diagram of P3-Pro double ammeter

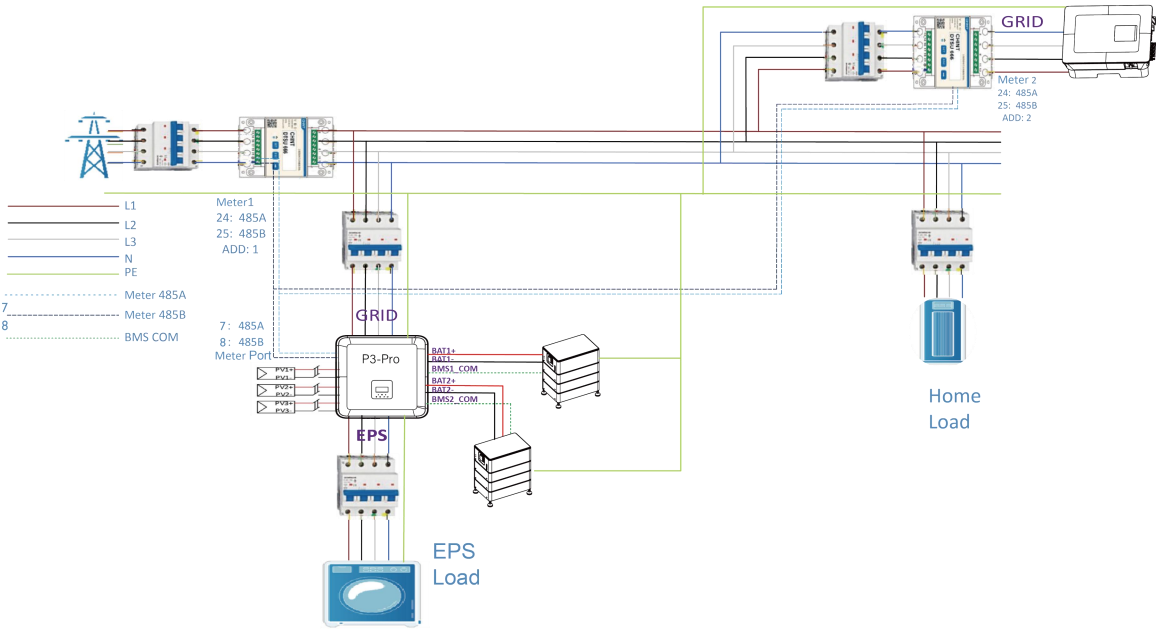

Important: Supports the function of the second electricity meter, which is used to measure the power generation of other power generation equipment and to summarize the monitoring data on the website.

only provides one electricity meter. The address of one of the meter is 1, which is used to measure the power consumption in the home to achieve spontaneous self-use. The address of the other meter is 2, which is used to measure the power generated by another power generation device in the home.

The addresses of the above two meters need to be corresponding, otherwise the flow diagram will be

affected. The addresses of the above two meters cannot be the same otherwise the functions will be affected.

Work modes	Description
Self-use (with PV Power)	Priority: load>battery>grid The energy produced by the PV system is used to optimize self-consumption. The excess energy is used to charge the batteries, then exported to grid.
Self-use (without PV Power)	When no PV is supplied, the battery will discharge for local loads first. Battery will charge when excess generation from other generation sources is detected.
Feed in priority	Priority: load>grid>battery In the case of the external generator, the power generated will be used to supply the local loads firstly, then export to the public grid. The redundant power will charge the battery.
Back up mode	When the grid is off, system will supply emergency power from PV or battery to supply the home loads (Battery is necessary in EPS mode).
PeakShaving	The system can be set to provide a peak shaving function. A Peak Shaving limit must be set by adjusting "Import Limit" to the desired value. We can increase the peak shaving support uptime by setting the "Threshold SOC". When the battery is above the "Threshold SOC" the system will work in "Self-Use mode. When the battery is below the "Threshold SOC" the peak shaving function will be the priority and the system will only provide power from the battery when the "Import Limit" is exceeded. When below the "Threshold SOC" the system will charge from the grid when there is available power without exceeding the "Import Limit". This is to ensure prolonged Peak Shaving support for extended periods. If the "Import Limit" is exceeded constantly for an extended period of time, the peak shaving function can only guarantee successful operation while energy remains within the battery. If the battery designated "low level" is reached, the peak shaving function will cease.

★Charging time is when the battery is charged within the set time range. The setting of charging time can be used in the above work modes. The charging period is mainly used to set the charging time from the power grid to the battery. The PV can also charge the battery when there is sufficient PV outside of charging time.

3.2 Dimensions

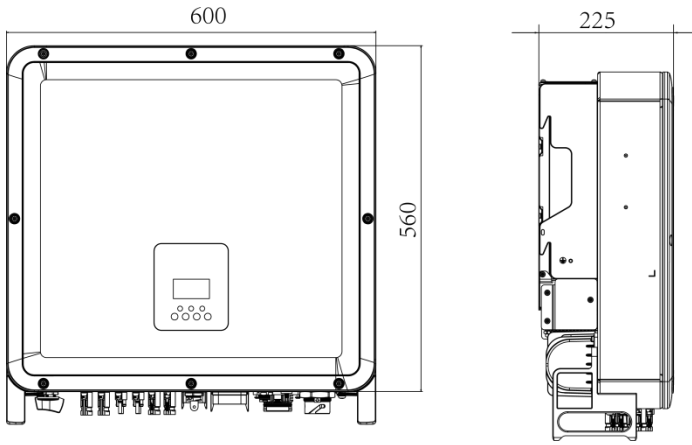

● This image is for reference only. The actual product received shall be final.

3.3 Terminals of inverter

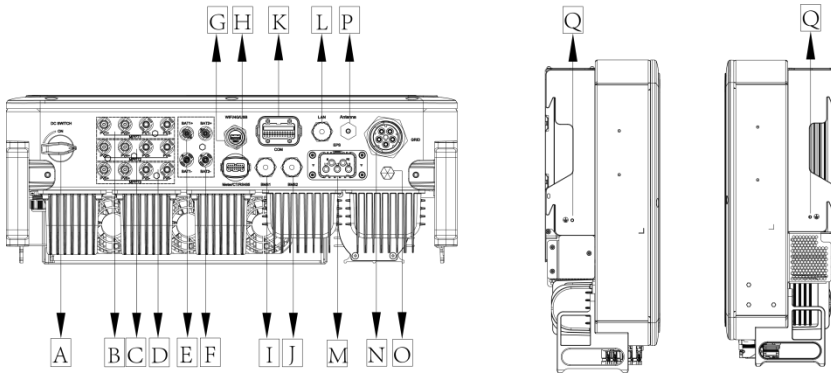

No.	Description	No.	Description
A	DC Switch	J	BMS2
B	MPPT1	K	COM
C	MPPT2	L	LAN
D	MPPT3	M	EPS
E	BAT1	N	GRID
F	BAT2	O	Waterproof Lock Valve
G	USB/WIFI/4G	P	Antenna
H	METER/CT/RS485	Q	Grounding Screw
I	BMS1		

Note: Only authorized personnel are permitted to set the connection.

4 Technical Data

4.1 PV Input (For P3 Pro Only)

Model	P3-Pro-15.0	P3-Pro-20.0	P3-Pro-25.0	P3-Pro-30.0
Max. Array Power [Wp]	30000	40000	50000	60000
Max. DC input power [W] ^[1]	22500	30000	37500	45000
Max. DC voltage [V] ^[2]	1000	1000	1000	1000
Nominal DC operating voltage [V]	750	750	750	750
Max. input current [A]	32/32/32	32/32/32	32/32/32	32/32/32
Max. short circuit current [A]	40/40/40	40/40/40	40/40/40	40/40/40
MPPT voltage range [V]	150-850	150-850	150-850	150-850
MPPT voltage range (full load) [V]	170-850	230-850	280-850	340-850
Start-up voltage [V]	160	160	160	160
No. of MPP trackers	3	3	3	3
Strings per MPP tracker	2/2/2	2/2/2	2/2/2	2/2/2

* More technical characteristics are available on demand and customized.

[1] Per MPP max. PV input power 15kW.

[2] For 1000V system, Maximum operating voltage is 950V. PV input voltage greater than 955V, PV over-voltage error will be reported.

4.2 Battery

Model	P3-Pro-15.0	P3-Pro-20.0	P3-Pro-25.0	P3-Pro-30.0
Battery Type	Lithium battery			
Battery voltage [V]	150-800			
Full AC load Battery voltage [V]	160-790	220-790	270-790	330-790
Max. Charge/ discharge current [A]	50+50	50+50	50+50	50+50
Number of battery input	2	2	2	2

4.3 AC Output/Input

Model	P3-Pro-15.0	P3-Pro-20.0	P3-Pro-25.0	P3-Pro-30.0
AC OUTPUT				
Nominal AC power [VA]	15000	20000	25000	30000
Max. apparent AC power [VA]	16500	22000	27500	33000
Rated grid voltage (AC voltage range) [V]	400V/230VAC;380V/220VAC,3L/N/PE			
Rated grid frequency [Hz]	50/60Hz, ±5Hz			
Max. AC current [A] (Per phase)	25.0	33.3	41.7	50.0
Power Factor	1(Adjustable from 0.8 leading to 0.8 lagging)			
Export Control	YES			
THDI	<3%@rated power			
AC INPUT				
Max. AC power [VA]	22500	30000	35000	35000
Rated grid voltage (AC voltage range) [V]	400V/230VAC;380V/220VAC,3L/N/PE			
Rated grid frequency [Hz]	50/60Hz, ±5Hz			
Max. AC current [A] (Per phase)	34.1	45.5	53.0	53.0
AC inrush current [A]	15A@0.5ms			
Power Factor	1(Adjustable from 0.8 leading to 0.8 lagging)			

4.4 EPS Output

Model	P3-Pro-15.0	P3-Pro-20.0	P3-Pro-25.0	P3-Pro-30.0
EPS OUTPUT (WITH BATTERY)				
Max. apparent AC Power [VA]	15000	20000	25000	30000
Peak apparent AC Power [VA] (60s)	18000	24000	30000	36000
Rated output voltage [V]	400V/230VAC;380V/220VAC,3L/N/PE			
Rated grid Frequency [Hz]	50/60			
EPS Max current [A] (Per phase)	22.7	30.3	37.9	45.5
Power Factor	1(Adjustable from 0.8 leading to 0.8 lagging)			
Parallel operation	Yes@max10 Pcs			
Switch time	<10ms			
THDV	<3%@rated power			

4.5 Efficiency and Protection

Model	P3-Pro- 15.0	P3-Pro- 20.0	P3-Pro- 25.0	P3-Pro- 30.0
EFFICIENCY				
MPPT efficiency	99.90%	99.90%	99.90%	99.90%
Max. Efficiency	97.20%	97.20%	97.10%	97.10%
Euro-efficiency	96.30%	96.30%	96.60%	96.60%
PROTECTION				
PV Reverse Polarity Protection	YES			
Battery Reverse Protection	YES			
Anti-islanding protection	YES			
Output Short Protection	YES			
Leakage current protection	YES			
Insulation Resistor Detection	YES			
Over Voltage category	III (AC side), II (DC side)			
Reverse connect protection	YES			
Over-current protection /Over-temperature protection	YES			
AC/DC surge protection	Type II/Type II			
AFCI protection	optional			
DC SWITCH	optional			
String monitoring function	optional			

4.6 General Data

DIMENSION AND WEIGHT

Dimensions (W*H*D) [mm]	600*560*225
Dimensions of packing (W*H*D) [mm]	720*680*370
Net Weight [kg]	52.5
Cooling	Smart FAN cooling
Inverter topology	Non-isolated
Communication interface	Meter, WIFI, 4G(optional), DRM, USB, BMS(CAN), RS485, Ethernet
LCD display	Backlight 16*4 character

ENVIRONMENT LIMIT

Installation	wall-mounted
Ingress protection	IP65 (for outdoor use)
Operating temperature range [°C]	-25...+60 (derating at +45°C)
Storage/Operation relative humidity	0%-95% (without condensation)
Altitude [m]	<4000
Protective class	I
Storage temperature [°C]	-40...+70
Standby consumption [W]	200W for hot standby, 20W for cold standby
Idle mode	YES
Button	Capacitive touch sensor *4
Buzzer	1, inside (EPS & Earth fault)

5 Installation

5.1 Check for Physical Damage

Danger!

- Do not wear loose clothing or jewelry when performing installation work, otherwise there may be a risk of electric shock!
- Before carrying out installation work, make sure that the mechanical strength of the installation location is sufficient to support the weight of the equipment, otherwise a mechanical hazard may result.

Warning!

All jumper components and component-mounted racks must be properly grounded, with unpainted contact surfaces.

Please strictly observe the following safety tips during installation operations. Otherwise, personal injury or death may occur.

- Installation must be performed properly by a professional under conditions that follow all warning tips.
- Nickel-plated copper is recommended, but aluminum can also be used.
- Remove the oxide layer and apply a suitable antioxidant caulking mix before connecting the aluminum busbar.
- For ease of installation and maintenance, it is recommended that sufficient space be allowed around the equipment: adequate cooling airflow, required clearances, and space needed for cables and cable support structures.

5.2 Unpackaging

Note!

Please open the package in order and do not knock it violently!

The following items must be checked before and after opening the box:









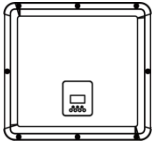

No.	Items
1	Check the appearance for any damage, scratches, dents, etc.
2	Check if all the accessories are included.
3	Check if the nameplate information matches the model of the ordered product.
4	Check the warning label for any damage, scratches, fading, etc.

Unpacking Precautions

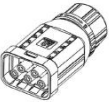
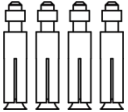
- During storage, the packaging must not be removed. It should only be removed when the equipment is ready for installation.
- Before unboxing, inspect the product's external packaging for any issues such as damage, breakage, moisture, dampness, or deformation.
- During unboxing, check the product and its accessories for surface defects like damage, rust, or dents.

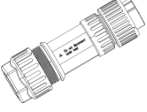
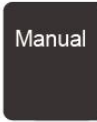
Packing List

When receiving the goods from the carrier, it is essential to conduct a thorough and careful inspection of the products. Check each received item against the delivery slip. If any items are missing or damaged, the carrier should be notified immediately upon discovery. The packing list is as shown below:

 <p>Inverter*1</p>	 <p>Bracket*1</p>	 <p>PV connectors (Only for P3-Pro) (6*positive, 6*negative)</p>	 <p>PV pin contacts (Only for P3-Pro) (6*positive, 6*negative)</p>
 <p>AC connector-EP*1</p>	 <p>Expansion tubes & Expansion screws*4</p>	 <p>Earth terminal*1</p>	 <p>AC connector-Grid*1</p>
 <p>Quick installation guide*1</p>	 <p>WiFi/GPRS/LAN (Optional)*1</p>	 <p>Meter*1</p>	 <p>Hexagonal screw*1 M4*16</p>

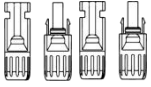

Battery connectors
(2*positive,
2*negative)



Battery pin contacts
(2*positive,
2*negative)



Hexagonal screw M5*10
grounding screw*1



COM1-12PIN*1

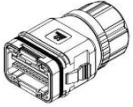

COM2-24PIN*1



GRID Outer Snap
Mechanical Lock*1

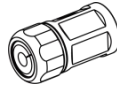

RJ45 connectors*3



Antenna*1

5.3 Installation Requirements

Selecting the optimal installation location for the inverter plays a very important role in its safe operation, life assurance and performance guarantee.





Environment Requirements

⚠ Warning!

The inverter generates high temperature during operation, so please install it in a location where it cannot be touched by human beings or isolate it by installing a protective net and erecting a safety warning sign on the outside.

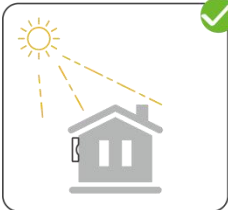
Note!

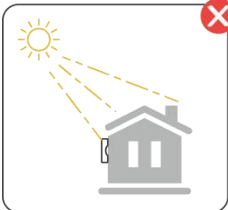
Site selection should be in accordance with local laws and regulations and relevant standard requirements.

Items	Requirements
Location	<ul style="list-style-type: none"> ● Not in direct sunlight. ● Not in areas where highly flammable materials are stored. ● Not in potential explosive areas. ● Not in the cool air directly. ● Not near the television antenna or antenna cable. ● Not higher than altitude of about 2000m above sea level. ● Not in environment of precipitation or humidity (>95%). ● Under good ventilation condition. ● The ambient temperature in the range of -25°C to +60°C. ● The slope of the wall should be within +5*. <p>The wall hanging the inverter should meet conditions below:</p> <p>A. Solid brick/concrete, or strength equivalent mounting surface;</p> <p>B. Inverter must be supported or strengthened if the wall's strength isn't enough (such as wooden wall, the wall covered by thick layer of decoration).</p> <p>Please avoid direct sunlight, rain exposure, snow laying up during installation and operation. entering the inverter, which could affect its performance and lifespan.</p> <div style="display: flex; flex-wrap: wrap; justify-content: space-around;"> <div style="text-align: center; margin: 5px;">  <p>No direct sunlight</p> </div> <div style="text-align: center; margin: 5px;">  <p>No rain exposure</p> </div> <div style="text-align: center; margin: 5px;">  <p>No snow build</p> </div> <div style="text-align: center; margin: 5px;">  <p>Direct sunlight</p> </div> <div style="text-align: center; margin: 5px;">  <p>Rain exposure</p> </div> <div style="text-align: center; margin: 5px;">  <p>Snow lay up</p> </div> </div>

⚠ Warning!

The intrusion of moisture can easily cause damage to the equipment! For normal use of the equipment:

- Do not open the cabinet door when the air humidity exceeds 95%.
- Avoid opening the cabinet door, performing maintenance or overhauling, etc., in rainy, lightning or humid weather conditions.

Requirements for Space

Adequate space must be reserved around the inverter, and a suitable installation angle must be selected to ensure sufficient room for installation and heat dissipation. The specific space requirements for a single inverter are illustrated in the following diagram.

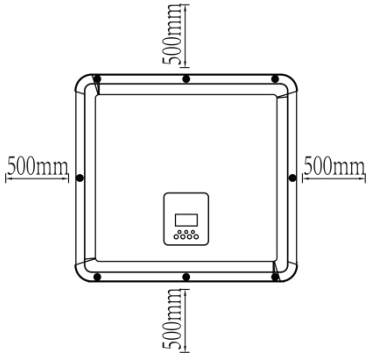

Position	Min. space (mm)
Left	500
Right	500
Top	500
Bottom	500

5.4 Tools Preparation

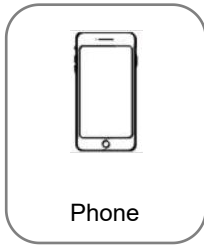
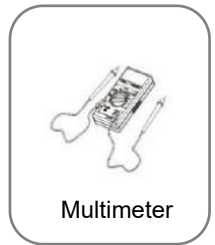
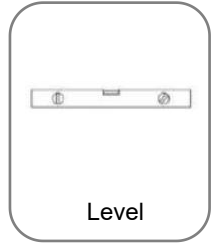

5.5 Inverter Handling

- When manually handling the unit, wear protective gloves, safety shoes, and other personal protective equipment to prevent injury during the process.
- Use correct lifting posture: Bend your knees to lower your center of gravity, grasp the inverter handles with both hands, and slowly straighten your knees, using the strength of your legs to lift the load. Keep the load close to your body and move using short, quick steps.
- Always maintain body balance during handling. Avoid making sudden turns or changes in direction.
- If a turn is necessary, execute it slowly and adjust your body posture in advance.
- If you feel fatigued or lack sufficient strength, you must stop handling immediately.

⚠ Warning!

Do not jerk or twist your body using the strength of your lower back, as this can lead to injury.

5.6 Installation Steps

Installation angle requirements: • Do not tilt the energy storage forward, horizontally, upside down, backward and sideways.

1. Installation space requirements:

When installing energy storage, ensure that there are no other equipment and flammable and explosive materials around, and reserve enough space to ensure the installation heat dissipation and safety isolation requirements. • During wall-mounted installation, no items are allowed to be placed under the energy storage.

Fix the bracket on the wall



Choose the place you want to install the inverter. Place the bracket on the wall and mark the position of the 2 holes from bracket.

⚠ Danger!

Before drilling, please make sure to avoid the water and electricity lines embedded in the wall to avoid danger.

Procedures

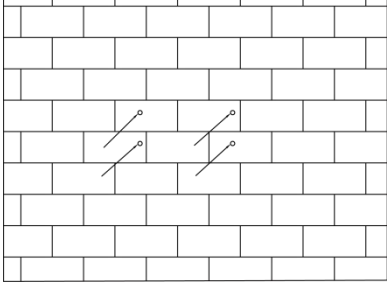
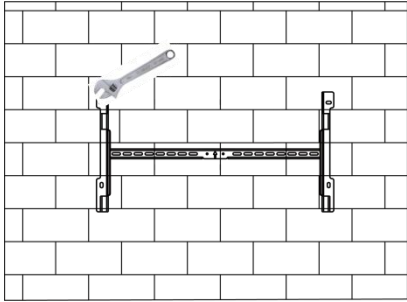
<p>Step 1</p>	<p>Installation position recommendation. Use a spirit level to adjust the installation position.</p> <div data-bbox="264 1441 705 1770"> </div> <div data-bbox="808 1501 1007 1528"> <p>Arrow pointing up.</p> </div> <div data-bbox="799 1608 1072 1645"> </div>
<p>Step 2</p>	<p>Drill holes with electric drill, make sure the holes are at least 40mm deep and 10mm wide, and then tighten the expansion tubes.</p>

	<p style="text-align: center;">⚠ Warning!</p> <p>Please pay attention to safety when using the tools. Unsafe use of the drilling tools may cause damage to the body.</p>
Step 3	<p>Please select solid brick-concrete structure and concrete wall for installation location. If other types of wall are selected, the wall must be made of fire-retardant materials and meet the load bearing requirements of the equipment.</p> 
Step 4	<p>Insert the M6 expansion bolt into the installation hole and then tighten the mounting bracket with nuts.</p>   

2. Match the inverter with wall bracket

Procedures

Mount the inverter to the bracket. Secure the inverter with the M5 screw and washer.

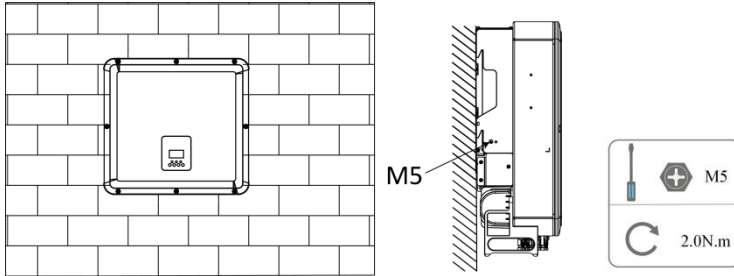

Warning!

Operators should wear protective goggles and dust masks to prevent dust from being inhaled into the lungs or falling into the eyes when punching.

Note!

The upper face of the expansion tubes must be made sure that it is level with the concrete wall surface and does not protrude from the concrete wall surface, otherwise it will make the wall plate unevenly placed on the wall surface.

6 Electrical Connection

6.1 Circuit Overview

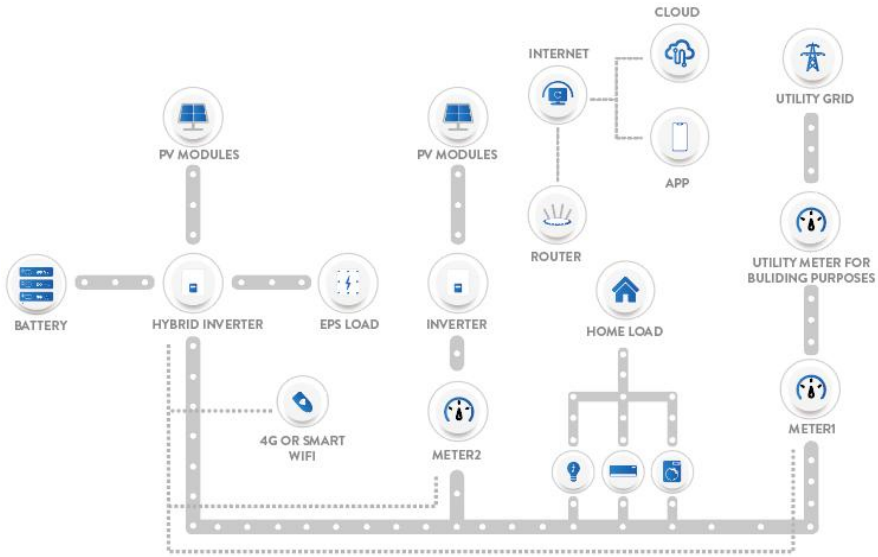

system overview

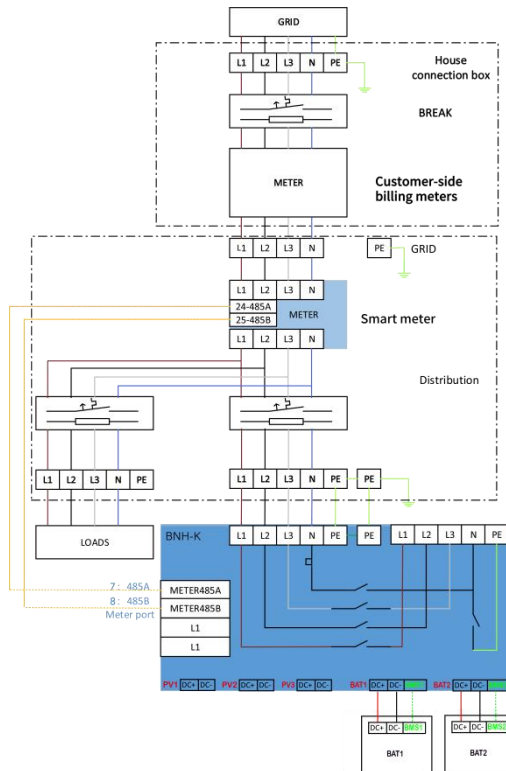

6.2 PV Connection (For P3-Pro Only)

Step 1: PV String Connection

For P3-Pro-15.0, P3-Pro-20.0, P3-Pro-25.0, P3-Pro-30.0

each MPPT can be connected to 2 strings of PV modules. PV input PV1 and PV2 connect to MPPT1, PV3 and PV4 connect to MPPT2, PV5 and PV6 connect to MPPT3, For the best use of PV power, Two strings connected to the same MPPT should be the same in PV string structure, including the type, number, tilt, and orientation of the PV modules.

Note!

Please choose a suitable external DC switch if the inverter does not have a built-in DC switch.

Warning!

PV module voltage is very high and within a dangerous voltage range, please comply with the electric safety rules when connecting.

The voltage difference between two strings connected to the same MPPT is too large, which may cause current to flow into the photovoltaic panel and damage it, this connection method, Fox ESS does not assume any responsibility.

Warning!

Please do not make PV positive or negative to ground!

Note!

PV modules: Please ensure they are the same type, have the same output and specifications, are aligned identically, and are tilted to the same angle. In order to save cable and reduce DC loss, we recommend installing the inverter as near to the PV modules as possible.

Step 2: PV Wiring

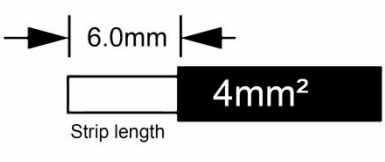
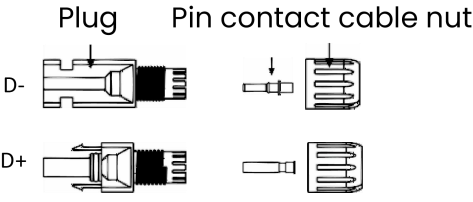
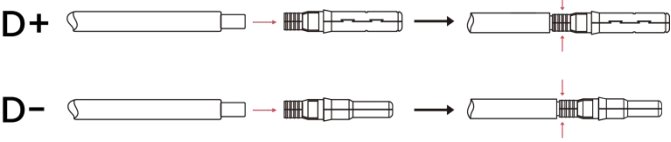
Procedures	
Step 1	<ul style="list-style-type: none"> • Turn off the DC switch. • Choose 4mm² wire to connect the PV module. • Trim 6mm of insulation from the wire end.  <p style="text-align: center;">Strip length</p>
Step 2	<p>Separate the DC connector (PV) as below.</p>  <p style="text-align: center;">Plug Pin contact cable nut</p>
Step 3	<p>Insert striped cable into pin contact and ensure all conductor strands are captured in the pin contact.</p> <p>Crimp pin contact by using a crimping plier. Put the pin contact with striped cable into the corresponding crimping pliers and crimp the contact.</p>  <p style="text-align: center;">Note!</p> <p>When making PV terminals, please make sure that the copper cores of PV positive and PV negative terminals and the copper cores on the inverter can be inserted, and use a multimeter to measure whether the positive and negative terminals are correct, otherwise the machine may not work normally or individual strings may not work.</p>

The maximum open-circuit voltage of PV should be less than 950V, otherwise an error may be reported when mppt cannot be traced.

- Insert striped cable into pin contact and ensure all conductor strands are captured in the pin contact.
- Crimp pin contact by using a crimping plier. Put the pin contact with striped cable into the corresponding crimping pliers and crimp the contact.

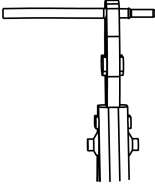

- Insert pin contact through the cable nut to assemble into back of the male or female plug. When you feel or hear a “click” the pin contact assembly is seated correctly.

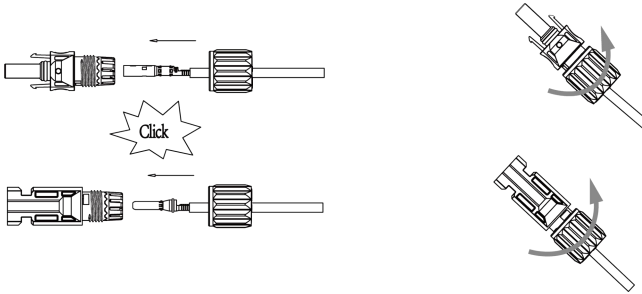

Unlock the DC connector

Danger!

Before separating the DC connector, make sure that there is no current on the DC connector. You can measure it with current clamp or disconnect the DC switch, otherwise serious safety accidents may occur.

Make sure that the power cable connected to the inverter is connected vertically and that the vertical length is greater than 30 cm. If the cable is bent close to the terminals, it may cause poor line contact and result in burnt terminals.

- Use the specified wrench tool.
- When separating the DC + connector, push the tool down from the top.
- When separating the DC - connector, push the tool down from the bottom.
- Separate the connectors by hand.

6.3 Battery Connection

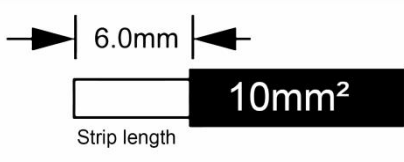
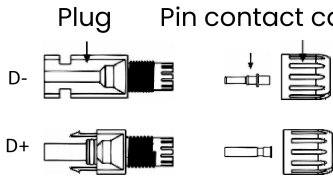
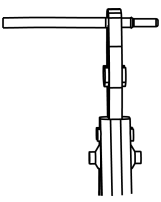
Procedures	
Step 1	<p>Turn off the DC switch. Choose 10mm² wire to connect the battery. Trim 6mm of insulation from the wire end.</p> 
Step 2	<p>Separate the DC connector (battery) as below.</p>  <p style="text-align: center;">Note!</p> <p>We offer matching battery power harnesses and communication harnesses. Please use matching harness. The matched battery power harness and communication harness are in the battery packaging box.</p>
Step 3	<p>Insert striped cable into pin contact and ensure all conductor strands are captured in the pin contact. Crimp pin contact by using a crimping plier. Put the pin contact with striped cable into the corresponding crimping pliers and crimp the contact.</p> 
Step 4	<p>Insert pin contact through the cable nut to assemble into back of the male or female plug. When you feel or hear a "click" the pin contact assembly is seated correctly.</p>

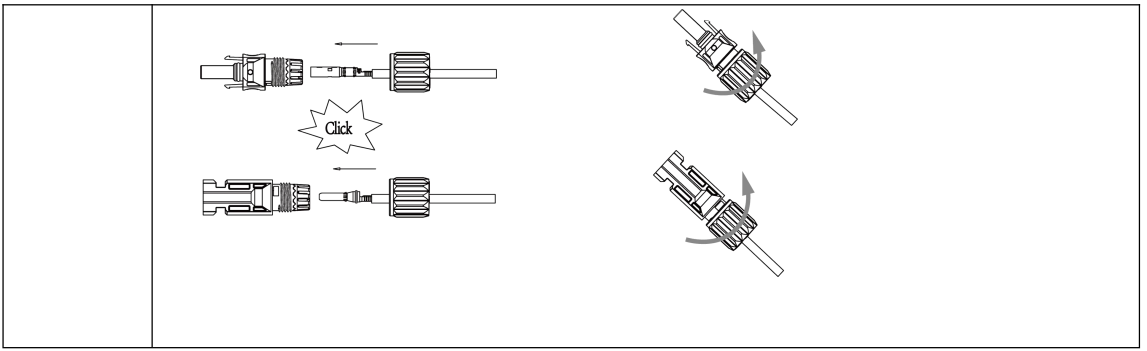

Note:

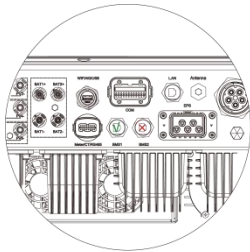

BAT1+/- ← BMS1

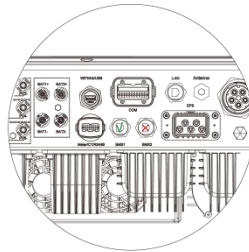

BAT2+/- ← BMS2

Unlock the DC connector

Danger!

Before disconnecting the DC connector, make sure that there is no current on the DC connector. You can use the current clamp to measure or disconnect the battery switch, otherwise serious safety accidents may occur. At the same time, the harness on the battery cannot be reversed or shorted, which will cause irreparable damage to the battery or inverter.

- Use the specified wrench tool.
- When separating the DC + connector, push the tool down from the top.
- When separating the DC - connector, push the tool down from the bottom.
- Separate the connectors by hand.

6.4 Grid Connection

Step 1: Grid String Connection

P3-Pro series inverters are designed for three-phase grid. Per voltage range is 220/230/240V; frequency is 50/60Hz. Other technical requests should comply with the requirement of the local public grid.

Model (kW)	15.0	20.0	25.0	30.0
Cable (ON-GRID)	6.0-10.0mm ²	10.0-16.0mm ²	10.0-16.0mm ²	10.0-16.0mm ²
Micro-Breaker	50A	63A	63A	80A
Model (kW)	15.0	20.0	25.0	30.0
Cable (EPS)	6.0-10.0mm ²	10.0mm ²	10.0mm ²	10.0mm ²
Micro-Breaker	50A	63A	63A	80A

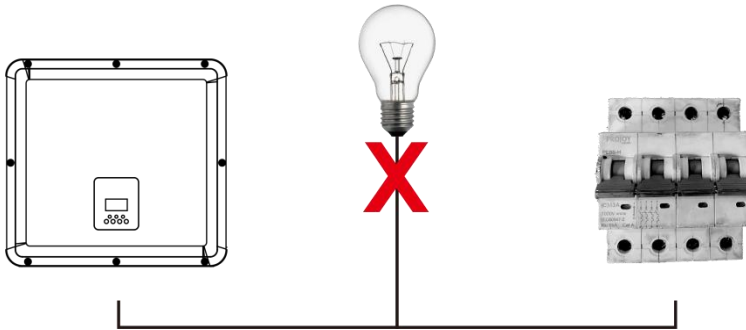

⚠ Warning!

A micro-breaker for max output overcurrent protection device shall be installed between inverter and grid, and the current of the protection device is referred to the table above, any load SHOULD NOT be connected with the inverter directly.

Step 2: Grid Wiring

- Check the grid voltage and compare with the permitted voltage range (refer to technical data).
- Disconnect the circuit-breaker from all the phases and secure against re-connection.

Trim the wires:

- Trim all the wires to 52.5mm and the PE wire to 55mm.
- Use the crimping pliers to trim 12mm of insulation from all wire ends as below.

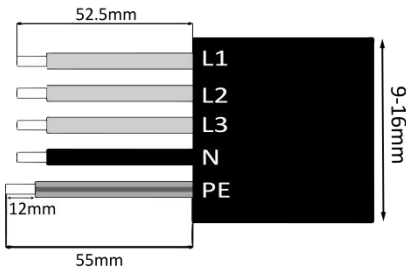

L1/L2/L3: Brown/Red/Green or Yellow Wire

N: Blue/Black Wire

PE: Yellow & Green Wire

Note: Please refer to local cable type and color for actual installation.

Procedures	
Step 1	<p>Separate the Load plug into 4 parts as below.</p>
Step 2	<p>Insert the sleeve assembly into the cable.</p>
Step 3	<p>Install the copper wire into the plug terminal and lock the screw.</p>

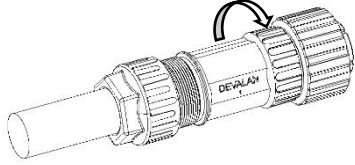
Step 4	Lock the sleeve and the plug (3~4N·M).
	

A. EPS Wiring

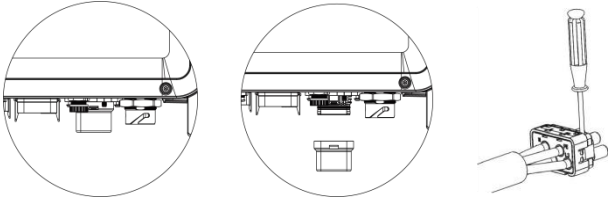
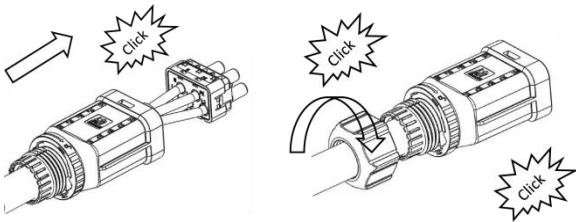
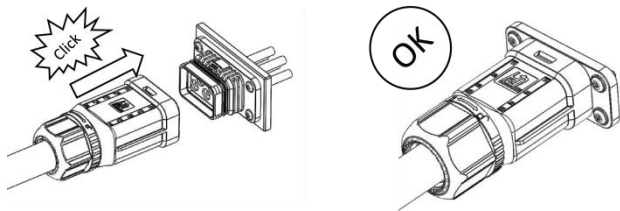
Step 1	Tighten the wire with a screwdriver, The torque of the crimp screw is $2.0 \pm 0.1 \text{N}\cdot\text{m}$.
	
Step 2	Put the sealing body and yarn trapper into the main body, screw the lock nut into the main body, and the torque is $(2.5 + / - 0.5 \text{N}\cdot\text{m})$.
	
Step 3	The female end of the wire is inserted into the male end of the line and accompanied by a click sound, and the installation is complete.
	

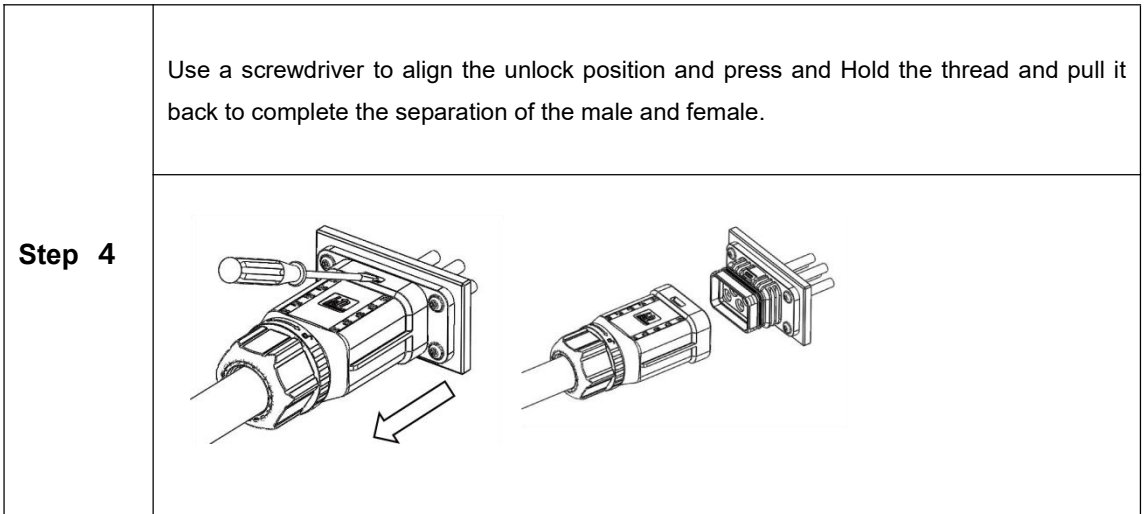

B. GRID Wiring



Note!

The wiring of the power grid must be connected to the N line, otherwise the machine will report an error and cannot work normally. The SW BUS Volt fault will appear. The method to detect whether the N line is connected is to measure whether the voltage of each phase is within the normal working voltage range separately. Then disconnect one of the live wires and check whether the voltage of the other two phases is within the range. If it is within the range, it means that the N wire is connected. If, after disconnecting the live wire, the voltage of the other two phases changes, it means that the N wire is not connected.

NOTE: Maximum accepted value between N and PE is 10 Volts. Otherwise, if higher this can lead to ground faults.

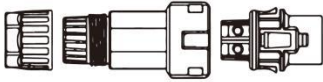
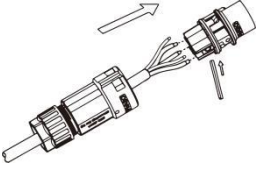
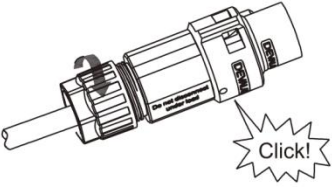
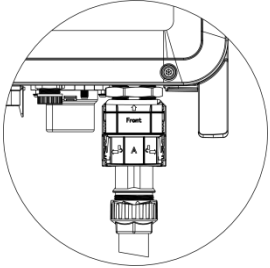
Separate the ON-GRID plug into three parts as below.

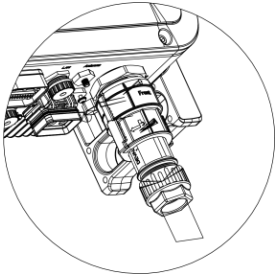
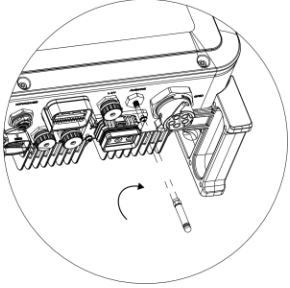
Procedures	
Step 1	<p>Hold middle part of the female insert, rotate the back shell to loosen it, detach it from female inset.</p> <p>Remove the cable nut (with rubber insert) from the back shell.</p> 
Step 2	<p>Slide the cable nut and then Install the back shell onto the cable.</p> 
Step 3	<p>Push the threaded sleeve into the socket, tighten up the cap on the terminal and the torque is (4-5N.m).</p> 
Step 4	<p>Push the threaded sleeve to connection terminal until both are locked tightly on the inverter.</p> 
Step 5	<p>Remove the GRID connector: Press the bayonet out of the slot with a small screwdriver or the unlock tool and pull it out, or unscrew the threaded sleeve, then pull it out.</p>

	
Step 6	<p>Mounting the External Antenna Hand Tight</p> 
Step 7	<p>Description of the wiring wire diameter</p>  <p>6mm² Wire Harness 10mm² Wire Harness 16mm² Wire Harness</p>

6.5 Earth Connection

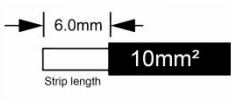
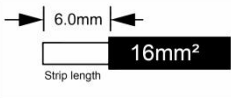
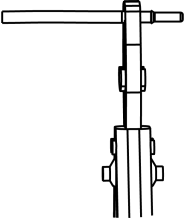
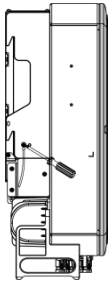
Procedures	
Step 1	<p>Trim 6mm of insulation from the wire end.</p> <div style="display: flex; align-items: center; margin-bottom: 10px;">  <div style="margin-left: 10px;"> <p>10-20KW</p> </div> </div> <div style="display: flex; align-items: center;">  <div style="margin-left: 10px;"> <p>24.9-30KW</p> </div> </div>
Step 2	<p>Insert striped cable into earth terminal and ensure all conductor strands are captured in the earth terminal.</p> <p>Crimp earth terminal by using a crimping plier. Put the earth terminal with striped cable into the corresponding crimping pliers and crimp the contact.</p> <div style="text-align: center; margin-top: 20px;">  </div>
Step 3	<p>Use the crimping pliers to press the ground cable into the ground terminal, screw the ground screw with screwdriver as shown below.</p> <div style="text-align: center; margin-top: 20px;">  </div>

6.6 Communication Connection

Communication Device Installation (Optional)

P3-Pro series inverters are available with multiple communication options such as WiFi-, GPRS-, LAN- or 4G-Dongle, RS485 and Smartmeter with an external device.

Operating information like output voltage, current, frequency, fault information, etc., can be monitored locally or remotely via these interfaces.

WiFi/ GPRS/ LAN (Optional)

The inverter has an interface for WiFi/GPRS/LAN/4G-Dongle that allow this device to collect information from inverter; including inverter working status, performance etc., and update that information to monitoring platform (the WiFi/GPRS/LAN/4G-Dongle is available to purchase from your local supplier).

Connection steps:

1. For GPRS device: Please insert the SIM Card (please refer to the GPRS product manual for more details).
2. Plug the WiFi/ GPRS/ LAN 4G-Dongle into “WiFi/GPRS/LAN 4G-Dongle” port at the bottom of the inverter.
3. For WiFi device: Connect the WiFi with the local router, and complete the WiFi configuration (please refer to the WiFi product manual for more details).
4. Set-up the site account on the monitoring platform (please refer to the monitoring user manual for more details).

WiFi configuration for smart WiFi

WiFi Stick Installation

Alarm: The collector can only be plugged into the inverter, not any other device.

Step 1: For USB

Rotate the lock, make sure the triangle mark is on the front and centered. Plug the Smart WiFi into WiFi/GPRS port under the bottom (underside) of the inverter. Tighten the nut clockwise as following.

Step 2:

Power on the inverter (in accordance with the start-up procedure detailed in the inverter installation manual).

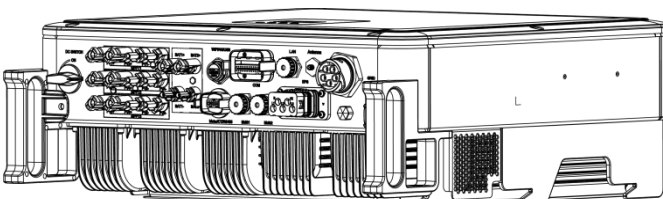

APP Installation:

Scan the QR Code below to download and install the Cloud APP on your smartphone.

**Configuration:**

Note: The module is powered on and started, please wait for one minute to start the WiFi Config.

Web Configuration.

Step 1:

Connect your mobile device with Smart WiFi. The SSID of the Smart WiFi is 'W-xxxxxxx' and the password is 'mtmt2020' .

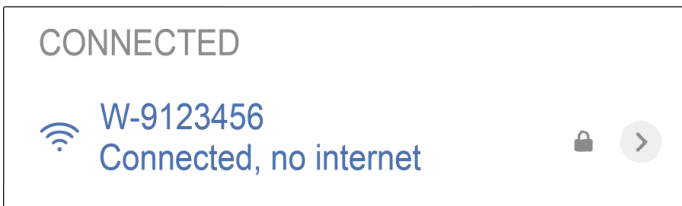

Step 2:

After connecting successfully. Open browser and enter 'https://192.168.1.1' on the address bar on top.

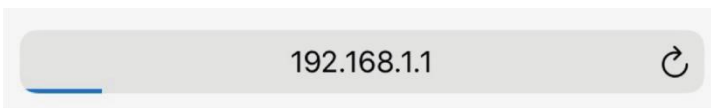

Step 3:

Drop down the WiFi SSID menu to find house router and input the house router's password. Click 'Save' .

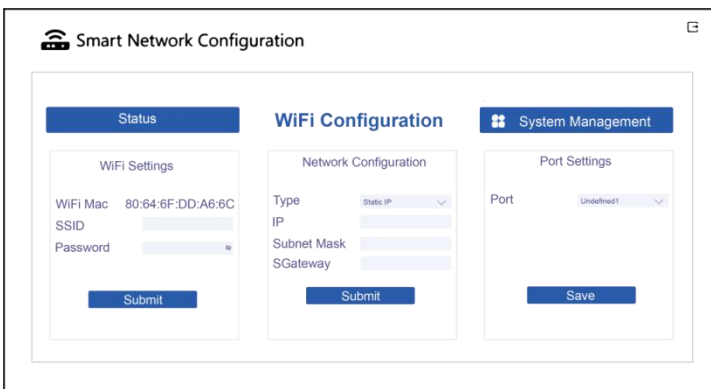

- Meter/RS485

The PIN definitions of Meter/485 interface are as below.

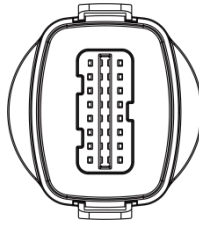

METER/CT/RS485 interface (20pin terminals)

1	2	3	4	5	6	7	8
DRY RLY2-	DRY RLY2+	DRY RLY1-	DRY RLY1+	/	/	Meter 485A	Meter 485B
9	10	11	12	13	14	15	16
GND TVS	GND COM	+12V SELV	RY Ctrl	/	/	/	/
17	18	19	20				
EMS 485A	EMS 485B	/	/				

Note:

- 1) GND TVS, RY Ctrl, these wiring terminals are tested in the factory, please do not connect them.
- 2) PIN1-PIN4 (DRY_RLY1+/-, DRY_RLY2+/-) is Implement SG ready function, please refer to user manual for details.
- 3) Installing communication terminals, it is necessary to ensure that the terminal cover and sealing plug are reliably sealed and connected.

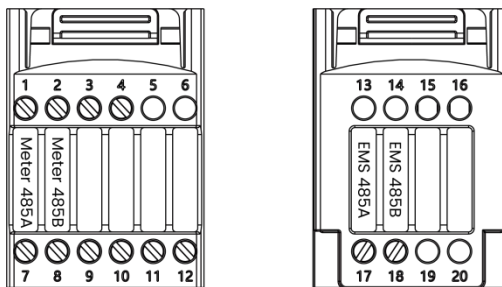

Note:

- 1) Pin11 is the power supply+12V, and Pin10 is the corresponding GND used;
- 2) The maximum load of the 12V power supply port cannot exceed 10W (instantaneous current cannot exceed 1A); Otherwise, it will damage the inverter.
- 3) Installing communication terminals, it is necessary to ensure that the terminal cover and sealing plug are reliably sealed and connected.

COM interface (24pin terminals)

1	2	3	4	5	6	7	8
/	RLY L-	RLY L+	RLY G-	RLY G+	ARM 485B	ARM 485A	GND COM
9	10	11	12	13	14	15	16
E STOP	/	/	VCC	DRM1	DRM2	DRM3	DRM4
17	18	19	20				
DRM0	GND COM	GND COM	/				

Note:

1) ARM 485A, ARM 485B, RLY L-, RLY L+, RLY G-, RLY G+ these wiring terminals are tested in the factory. please do not connect them.

2) PIN12-18 (VCC, DRM0-DRM4) is Implement RCR or DRM function, please refer to user manual for details.

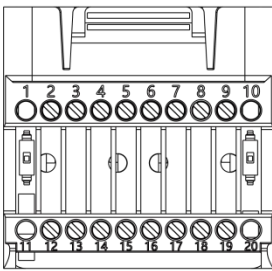

Parallel communication port

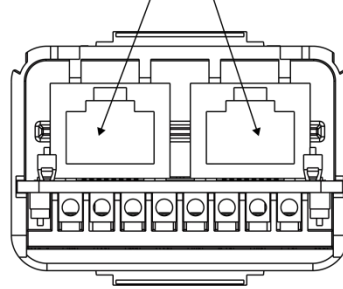

Note:

Compatible Meter type: DTSU666 (CHINT).

Please check and configure the meter before use:

Addr: 1;

Baud: 9600

Protocol: n.1

Please refer to the user manual of electricity meter for detailed setting steps.

- RS485

RS485 is a standard communication interface which can transmit the real time data from inverter to PC or other monitoring devices.

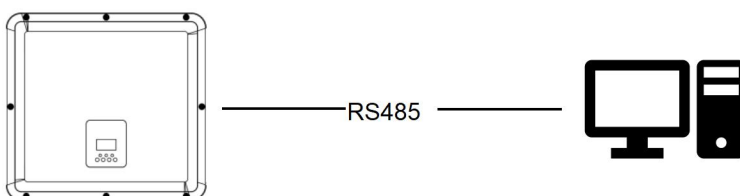

- Meter

The inverter has integrated export limitation functionality. To use this function, a power meter must be installed. For Meter installation, please install it on the grid side.

Note!

When connecting the electricity meter, please make sure that the way of the electricity meter is correct, otherwise it will affect the size of the load obtained by the inverter and affect the normal operation of the inverter. When the battery is available and can work normally, the machine provides the self-test function in the direction of the meter, which can be set in the meter interface.

Export control setting:

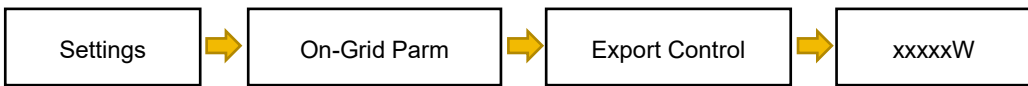

The electricity meter is connected as follows:

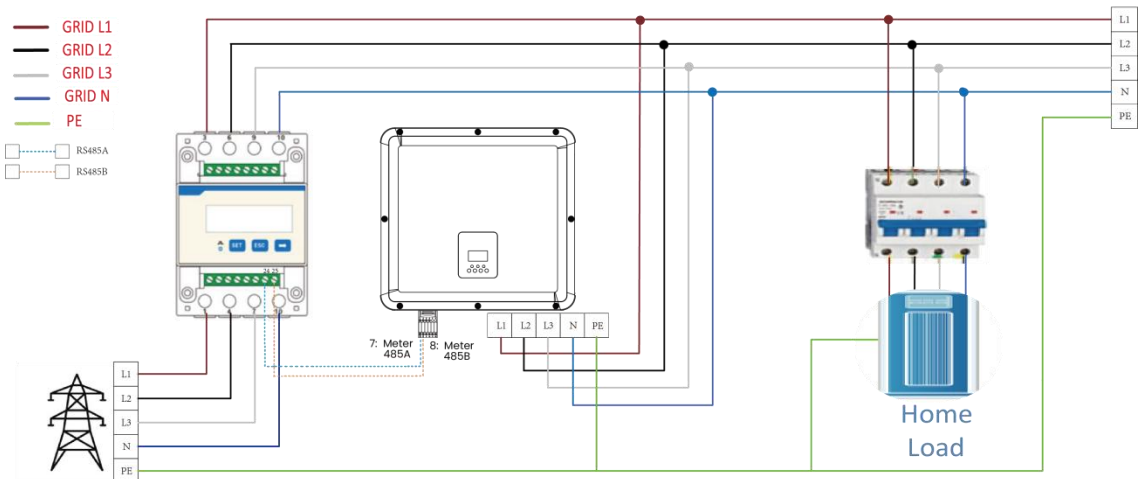

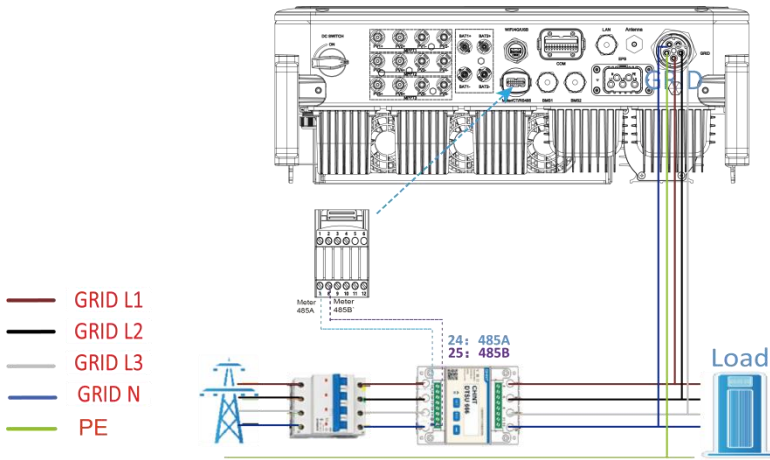

Note:

Standard meter is CHJNT DTSU 666 it can be used Max current of 80A; if higher Amps required, customers can choose same model + CTs.

Meter connection:

Meter Connection Diagram

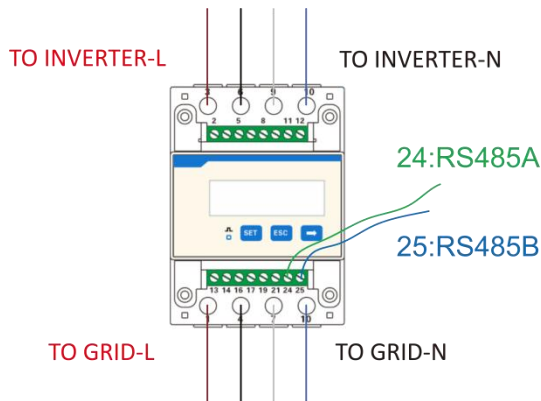

Insert L1/L2/L3/N wires and RS485A/B cable into the meter. Please refer to the meter wiring diagram on side of meter itself.

Connect RS485A to the 24 pins of the meter port and RS485B to the 25 pins of the meter port. Please use twisted pair cable.

The definition of the meter port refers to the METER/CT/RS485 interface(20pin terminals)in page 32.

The built-in meter is a regular meter, and if a CT meter is required, additional purchase is required.

CT Meter Connection Diagram :

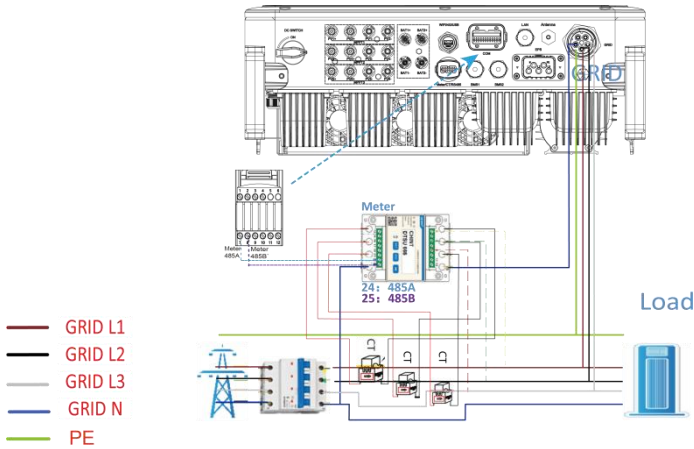

Insert L1/L2/L3/N wires, CT and RS485A/B cable into the meter. Please refer to the meter wiring diagram on side of meter itself.

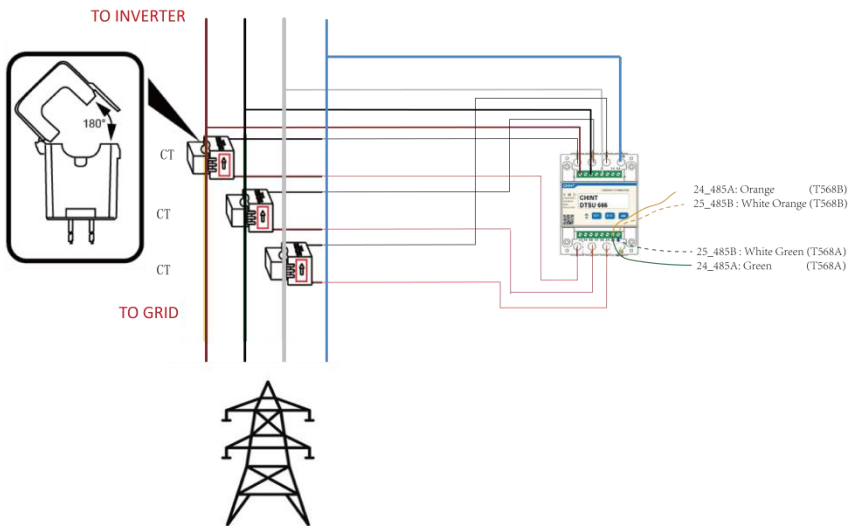

Notes: The 2,5,8 of the CT meter are connected to the three live wires L1, L2, and L3 respectively.

Connect RS485A to the 24 pins of the meter port and RS485B to the 25 pins of the meter port. Please use twisted pair cable.

The definition of the meter port refers to the METER/CT/RS485 interface(20pin terminals)in page 32.

The transformation ratio setting of a CT meter needs to be consistent with the transformation ratio of a CT meter. The transformation ratio setting method.

for a CT meter is as follows:

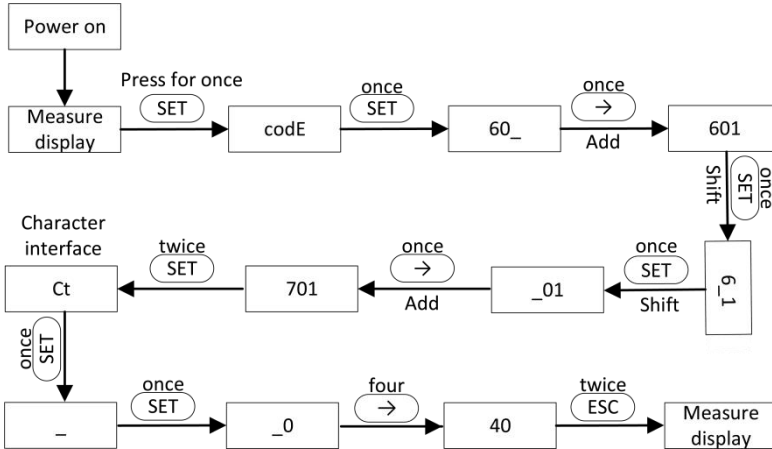

Schematic diagram of P3-Pro system 0 grid connection:

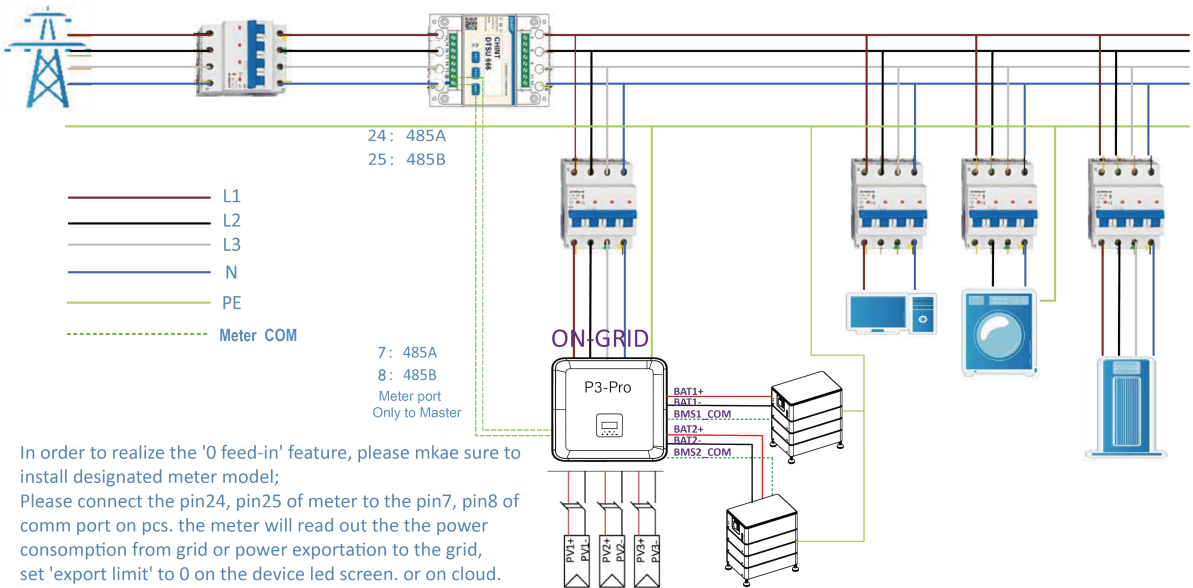

In order to realize the '0 feed-in' feature, please make sure to install designated meter model; Please connect the pin24, pin25 of meter to the pin7, pin8 of comm port on pcs. the meter will read out the the power consumption from grid or power exportation to the grid, set 'export limit' to 0 on the device led screen. or on cloud. will limit the export power to 0.

The inverter can also provide the use of two meters, using the second meter to read the power generated by another machine, where the address of the second meter is 2. When using the second meter function, you need to turn on the second meter function.

Note!

Only one meter is provided. If you need a second meter, consult your local installer or dealer.

The address of the second meter is 2. Please ensure that the address is 2, otherwise the communication of the first meter will be affected, and the output and monitoring data of the inverter will be affected.

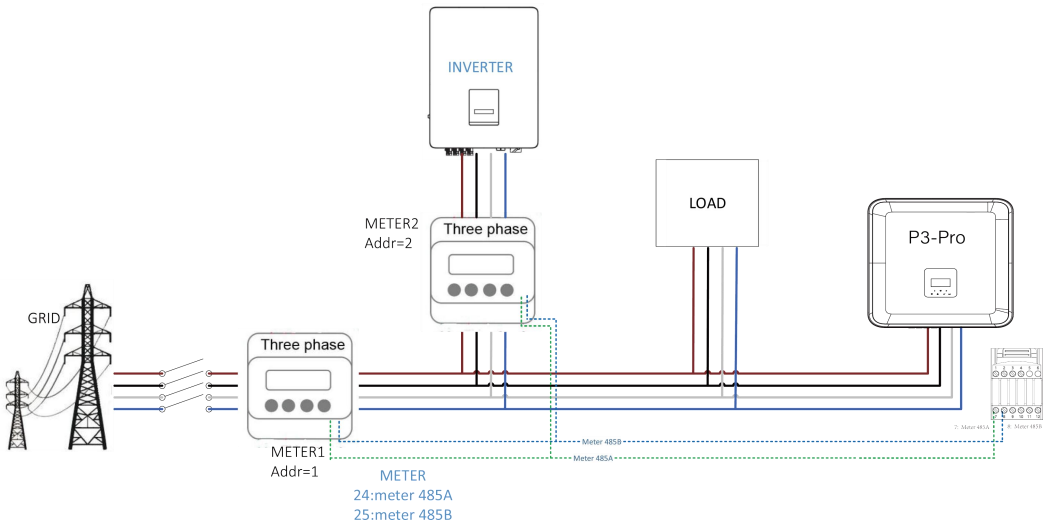

BMS

BMS-CANL: It is used for communication between the inverter and BMS. If this wire is poor, the communication between the inverter and BMS will not work properly. The stable SOC value displayed on the inverter home page is a good performance of communication. This line is very important for the energy storage system. Please ensure that it is not too long or in a complex environment.

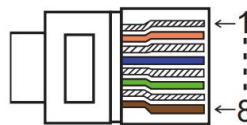

PIN	1	2	3	4	5	6	7	8
Definition	BAT-AWAKEN	GND COM	/	BMS CANL	BMS CANH	BMS CANH	BMS CANL	/



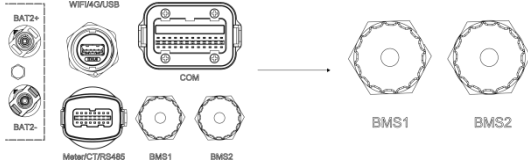
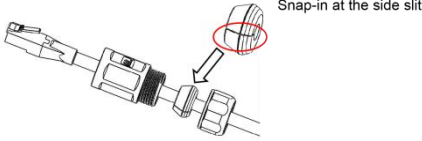
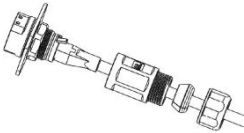
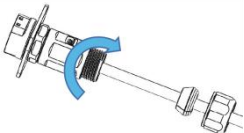
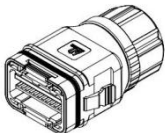





Connection steps:

Procedures	
Step 1	<p>Open the lid cover.</p> 
Step 2	<p>Pass the network cable through the locking nut, sealing plug and main body in turn. Snap-in the sealing plug at the side slit.</p> 
Step 3	<p>Insert the network cable plug into the RJ45 board end connector.</p> 
Step 4	<p>Lock the main body on the RJ45 board end connector with an open-ended wrench; torque $1.2 \pm 0.2 \text{ N} \cdot \text{m}$.</p> 
Step 5	<p>Insert the cable connector into COM port at the bottom of inverter and screw it tightly. Then insert other side of the network cable into PC or another device.</p> 

6.7 EPS Connection (Non-parallel State)

Common loads description

Under EPS mode, if need to connect the inductive load on EPS port, please ensure that the instantaneous power of the load at startup is lower than the maximum power of the EPS mode. Below table shows some conventional and reasonable loads for you reference. Please refer to your loads' manual for the actual specs.

Type	Power		Common equipment	Example		
	Start	Rated		Equipment	Start	Rated
Resistive load	X 1	X 1	 Incandescent lamp  TV	 100W Incandescent lamp	100VA (W)	100VA (W)
Capacitive load	X 2	X 1.5	 Fluorescent lamp	 40W Fluorescent lamp	80VA (W)	60VA (W)
Inductive load	X 3~5	X 2	 Fan  Fridge	 150W Fridge	450-750VA (W)	300VA (W)

For some motor loads, the starting current may be far more than 5 times the current, which is also not supported.

6.9 Inverter Start-Up

Please refer to the following steps to start up the inverter.

1. Ensure the inverter fixed well.
2. Make sure all wirings are completed.
3. Make sure the meter is connected well.
4. Make sure the battery is connected well.
5. Make sure the external EPS contactor is connected well (if needed).
6. Make sure the BMS buttons and battery switches are off.
7. Turn on the PV/DC switch (for Hybrid version only), AC-GRID breaker, EPS breaker and battery breaker, EPS breaker and battery breaker.
8. Set safety and system time on the screen according to the country and region where you are located.
9. If the main page shows "switch off", please long press "√" bottom to quickly go to the START/STOP page and set it to start. (Enter the settings page, default password is '0000').

Note:

- Add boot-up guide interface, the first boot-up need to select the safety regulations */** and set the time.
- Set the time on the inverter using the button or by using the APP.
- for Italy selftest : please scan this QR Code : (Gabriel/ HQ need to enter QR Code to jump.
- for Italy: you can choose grid code CEI -021A or CEI -021B,(CEI - 021 A must be selected if inverter is less than 11.08kW; CEI - 021 B if power is more than 11.08kW)

6.10 Inverter Switch Off

Please refer to the following steps to switch off the inverter.

1. Enter the settings page, select START / STOP and set it to stop.
2. Turn off the PV/DC switch (for P3-Pro only), AC breaker, EPS breaker and battery breaker.
3. Wait 5 min before you open the upper lid (if in need of repair).

7 Main function implementation

7.1 Parallel system wiring and setting

Each P3-Pro series system support Max. 10 units parallel connection for on-grid system or Max. 4 units parallel connection for off-grid system.

1) System Diagram

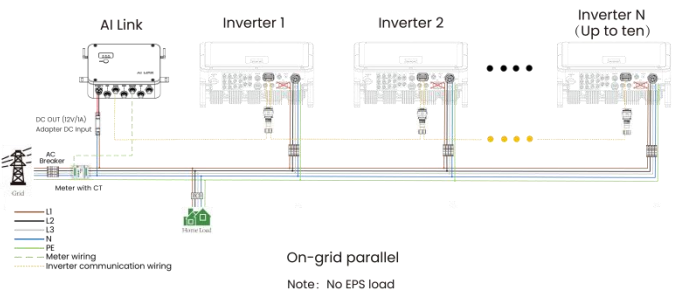
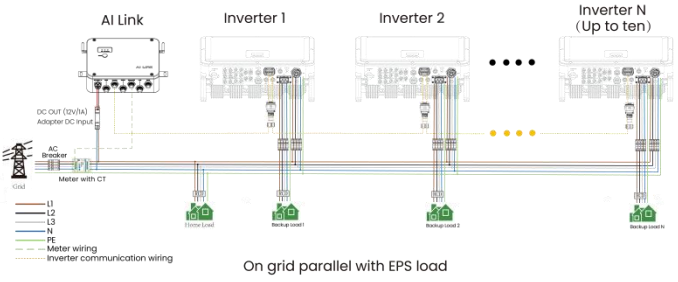
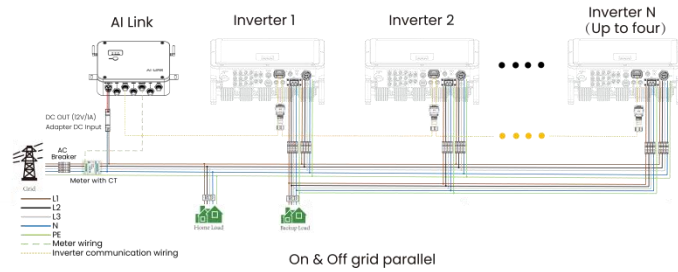

Note!

1. Parallel inverters need to be of the same type and power.
2. For "On grid parallel with EPS load" , "On&off grid parallel " scene, each inverter must be connected to the battery.
3. The cable length from each inverter's grid port to the grid connection point must be the same, and the cable length from each inverter's EPS port to the common load connection point must also be the same.

Note!

For P3 Pro series parallel function, Fox ESS AI-Link is mandatory. Please see AI-Link user manual for connection.

Parallel inverters need to be of the same type and power.

For "On grid parallel with EPS load" , "On&off grid parallel " scene, each inverter must be connected to the Battery.

Warning!

On & off grid parallel must ensure that the EPS port and GRID port of each machine are connected one by one. That is, EPS port L1 of each inverter must correspond to L1 on the network side, L2 must correspond to L2 on the network side, L3 must correspond to L3 on the network side, and N must correspond to N on the network side.

During parallel operation, the corresponding relationship between Grid ports L1/L2/L3/N and meters must be strictly corresponding: L1-->A, L2-->B, L3-->C, N -->N.

Does not assume any responsibility for machine damage or safety accidents caused by Wiring error for offline and parallel operation.

2) Wire Connection

Step1: Parallel Power wiring

Step2: Inverter communication wiring

Step3: Meter wiring

Step4: Power Supply

Step1 Parallel Power wiring

Please select the corresponding power wiring method according to different scenarios.

Step2 Inverter communication wiring

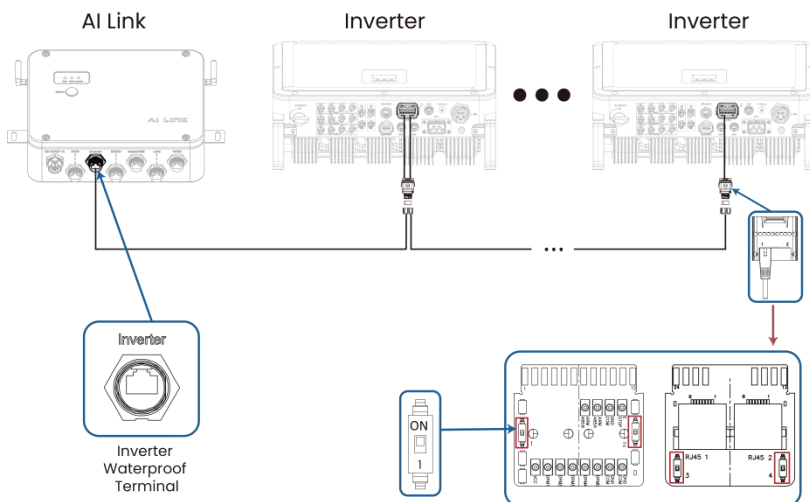

Push the 4 DIP switches (only the last inverter) to "ON" position

Step3 Meter wiring

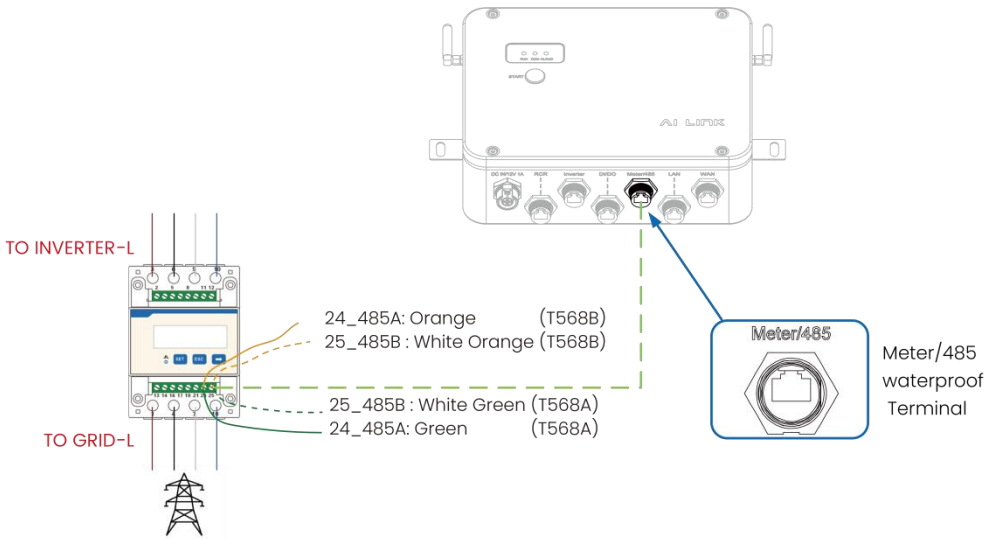
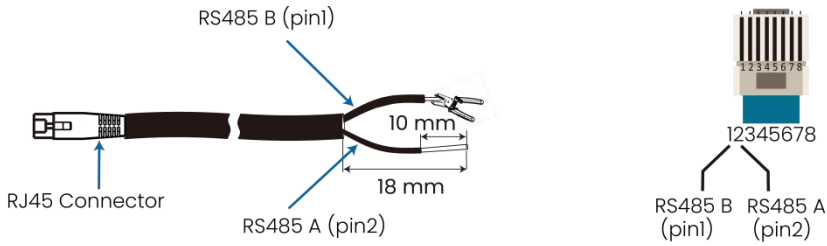

Note!

Grid-side inflow/outflow current < 80A, meter can be connected directly.

Wiring Table between the AI Link and the Meter.

	AI Link	Meter (CHINT DTSU666)
RS485 A	Pin2 (Meter/485, RS485- A1)	Pin24
RS485 B	Pin1 (Meter/485, RS485- B1)	Pin25

CT meter needs to be purchased separately, if required.

CT Meter Wiring Diagram:

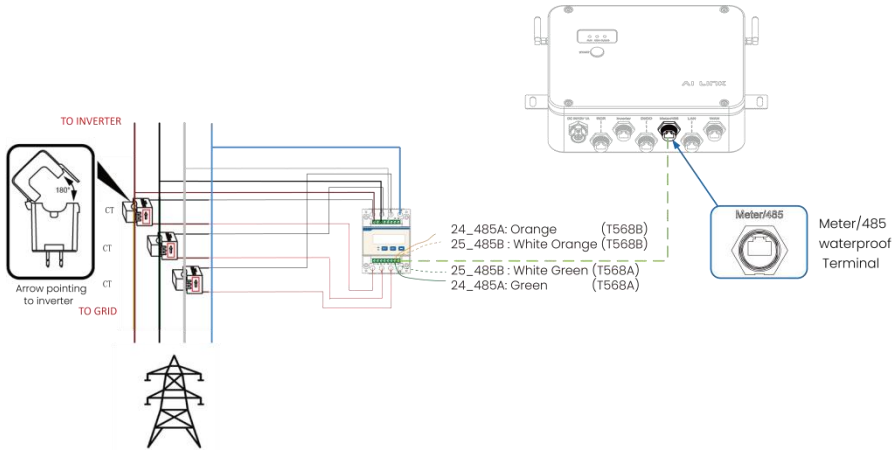

NOTE

Grid-side inflow/outflow current > 80A, use Current Transformer.

Step4 Power Supply

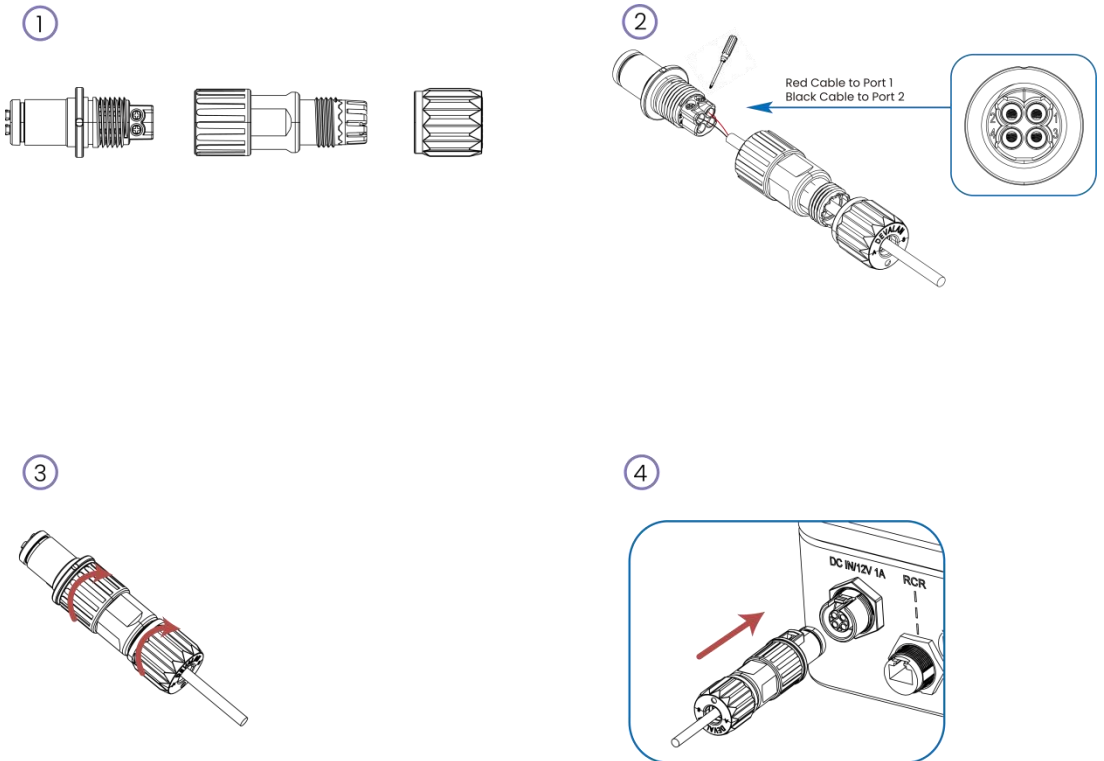

5

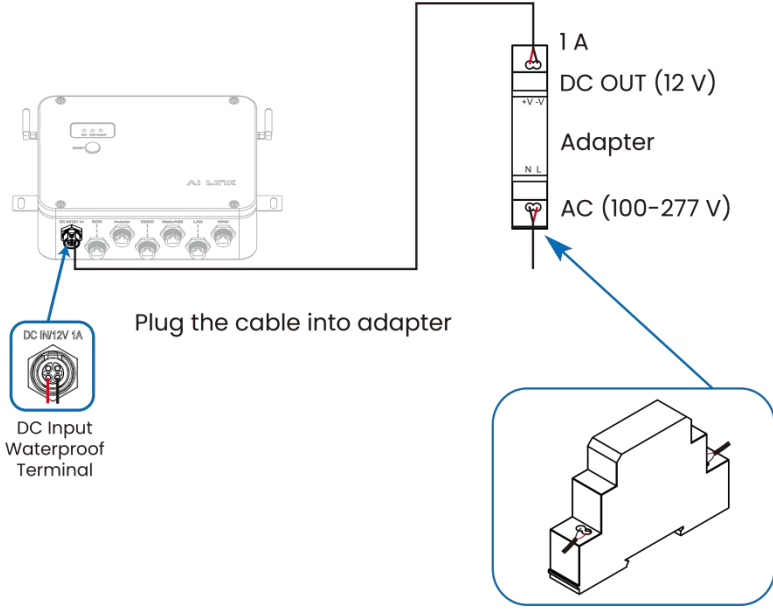

The system diagram is as follows:

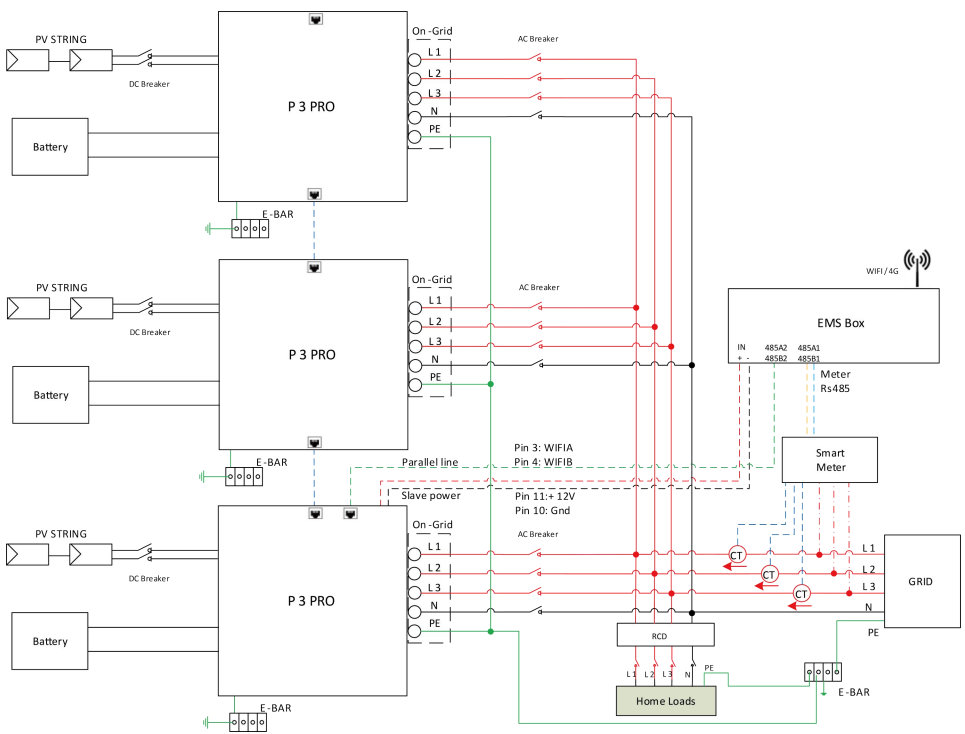

Pure on grid parallel

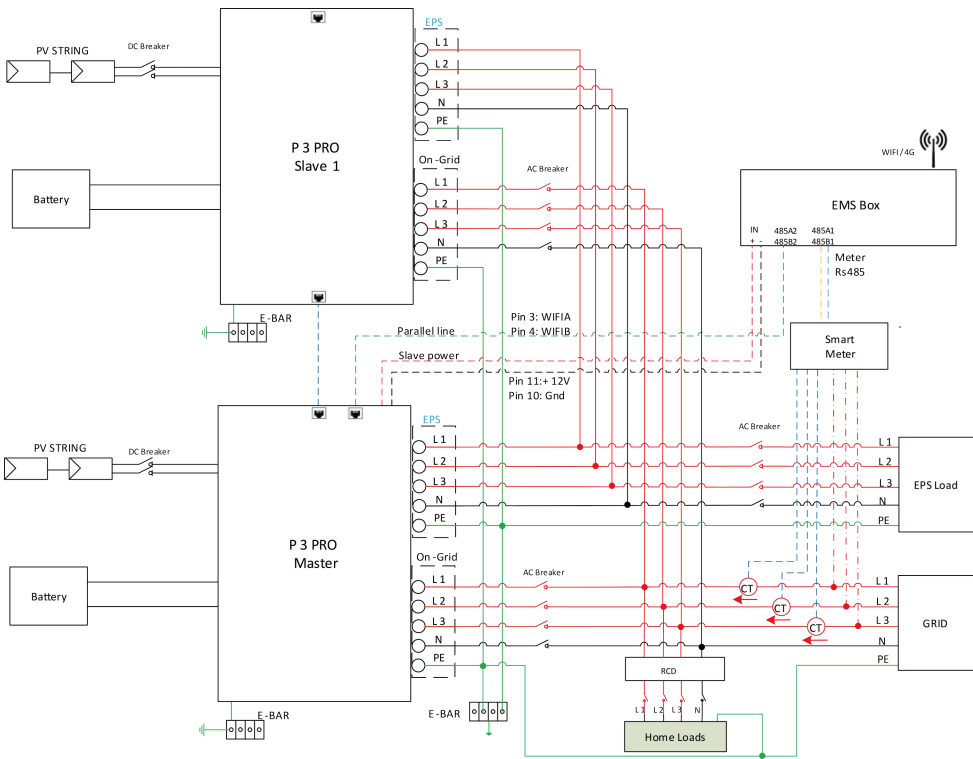

On & Off grid parallel

Work Modes in parallel system

There are two work modes in parallel system: On&OffGrid Mode and OnGridOnly Mode, and your acknowledge of different inverter’s work modes will help you understand parallel system better, therefore please read it carefully before operating.

On&OffGrid Mode: After connecting all the lines according to the installation instructions, if the master-slave Mode is not set, select one of them to set the “On&OffGrid Mode”, this inverter enters master mode.

OnGridOnly Mode: Once one inverter is set as a “On&OffGrid Mode”, all other inverters will display “OnGridOnly Mode”, then don't have to set anything up, can complete the off-grid parallel.

How to exit from parallel system

If one inverter wants to exit from this parallel system, please follow the steps below:

Step1: Disconnect all the network cables on the CAN port.

Step2: Enter setting page and click parallel setting, and choose "OnGridOnly Mode".

Step3: Restart inverter.

3) APP Configuration Reference

Please download the FoxCloud2.0 APP from Apple store or Google store.



Note!

Configure only ALLink networks, no inverter setup needed.

Note!

Make sure all communication cables between AI Link and inverters are connected.

Make sure all inverters and smart logger are powered on.

Step 1 Connect to network

1-1

Open APP, then click three point in the top right corner of login page, and choose "WLAN Configuration".

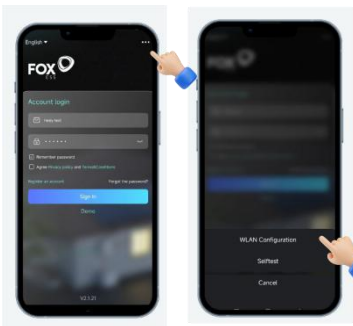

1-2

Keep Bluetooth on and wait for device searching. Then choose the device (EMS_XXXXXXXXXX) and click "Connecting Network".

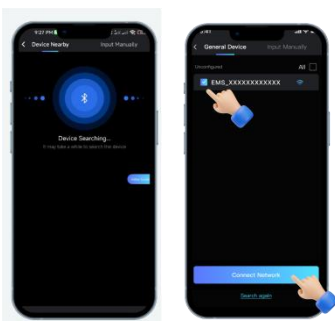

1-3

Choose SSID of home router and enter password, then click “Next”.



1-4

Wait for about 30s, it will complete the configuration. Then click “Finish”.

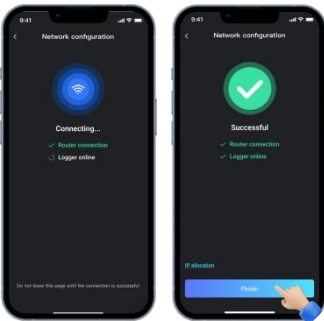

Step 2 Connect to device

Then it will start communicate with devices automatically. Please wait for 30 seconds. Then click “Finish”. Please check whether the number of devices is consistent with the actual number. If not, please click “Reconnect” or confirm the cable connection is correct.

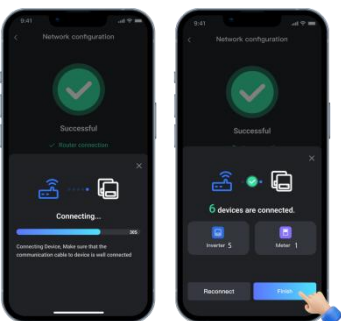

Step 3 Choose your scene

Select a scene based on the onsite cable connection. Then click “Confirm”.

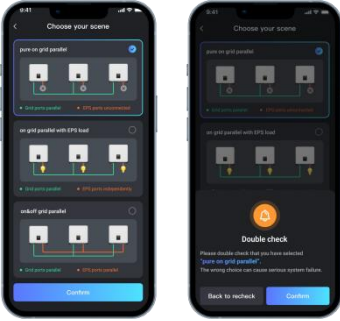

It means the network configuration and settings of AI Link are both successful. Then click “Got it”, it will turn to login page.

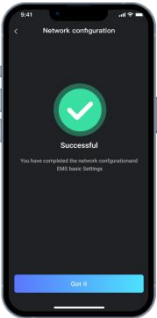

Step 4 Sign in

Enter your username and password, and click “sign in”.



Step 5 Create a plant

5-1

Click "Create a plant".



5-2

Click "Add Device"



5-3

Scan the SN of EMS logger, and click "Confirm".

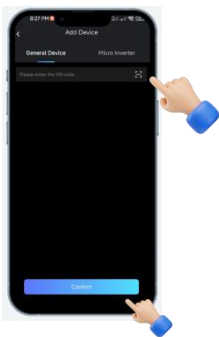

5-4

Enter the basic information, and click "Save".

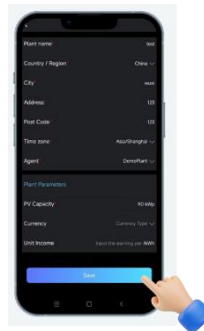

Step 6 Wait and refresh

It may need to wait for 3-5 minutes to upload inverters data, please be patient.

You can swipe to refresh this page.



Step 7 Check device

Click the rotating ring to go to the parallel page.



7.2 Drm wiring

DRM0 setting

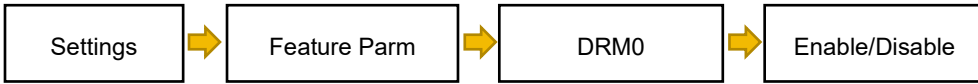

DryConfigure setting: DryConfigure Set the DryIn1 to DRM.

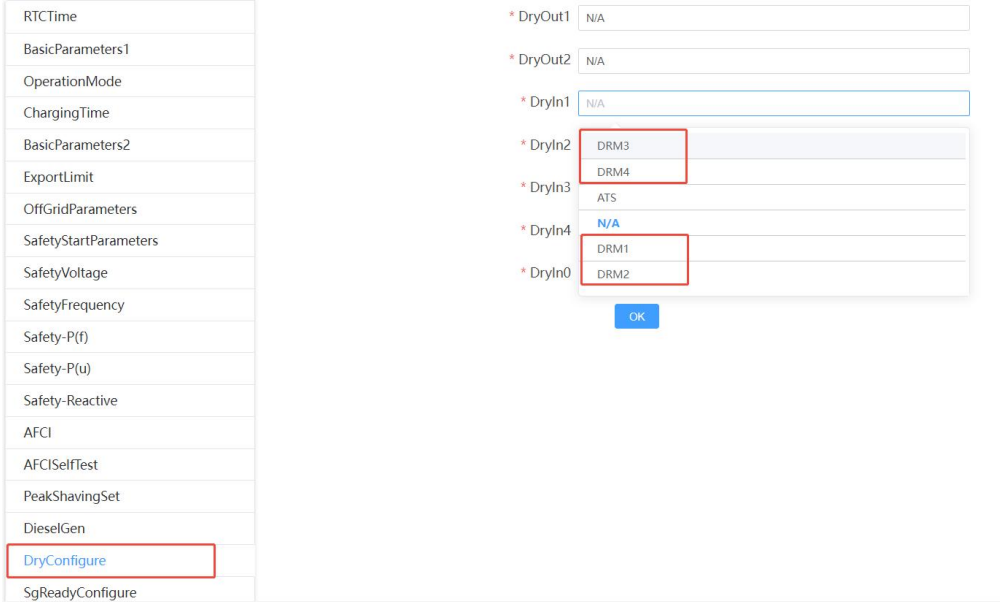

DRM supports several demand response modes by configuring control signals as below.

Mode	Asserted by shorting pins		Requirement
DRM0	VCC	DRM0	Operate the disconnection device.
DRM1	DRM1	DRM0	Do not consume power.
DRM2	DRM2	DRM0	Do not consume at more than 50% of rated power.
DRM3	DRM3	DRM0	Do not consume at more than 75% of rated power and source reactive power if capa
DRM4	DRM4	DRM0	Increase power consumption (subject to constraints from other active DRMs).
DRM5	DRM1	VCC	Do not generate power.
DRM6	DRM2	VCC	Do not generate at more than 50% of rated power.
DRM7	DRM3	VCC	Do not generate at more than 75% of rated power and sink reactive power if capabl
DRM8	DRM4	VCC	Increase power generation (subject to constraints from other active DRMs).

Note: Currently only supports DRM0 function, other functions are under development.

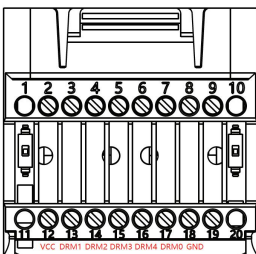

12	13	14	15	16	17	18
VCC	DRM1	DRM2	DRM3	DRM4	DRM0	GND

7.3 RCR wiring

DRM0 setting

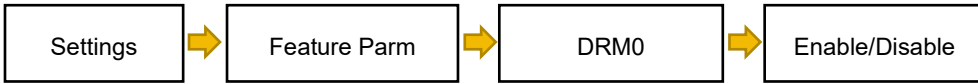

DryConfigure setting: DryConfigure Set the DryIn1 to DRM, DRM and RCR correspond as follows.

RTCtime
BasicParameters1
OperationMode
ChargingTime
BasicParameters2
ExportLimit
OffGridParameters
SafetyStartParameters
SafetyVoltage
SafetyFrequency
Safety-P(f)
Safety-P(u)
Safety-Reactive
AFCI
AFCISelfTest
PeakShavingSet
DieselGen
DryConfigure
SgReadyConfigure

* DryOut1 N/A

* DryOut2 N/A

* DryIn1 N/A

* DryIn2 **DRM3**
DRM4

* DryIn3 ATS

* DryIn4 N/A

* DryIn0 **DRM1**
DRM2

OK

The prerequisite for the use of this function is the selection of the German grid connection regulation VDE 4105 and the use of the RCR function.

The ripple control function is described below:

12	13	14	15	16	17	18
VCC	DRM1	DRM2	DRM3	DRM4	DRM0	GND

Mode	Asserted by shorting pins		Output active power
Normal	No contact closed		100%*Pr
Normal	Several contacts closed		100%*Pr
RCR1	DRM1	VCC	60%*Pr
RCR2	DRM2	VCC	30%*Pr
RCR3	DRM3	VCC	0%*Pr
RCR4	DRM4	VCC	Immediate OFF
Power Limit	DRM0	VCC	Max grid charge power limit to 4.2 kW

7.4 SG ready wiring and setting

- **SG Ready**

The Smart Grid Ready is controlled by the dry contact output (PIN3-PIN4) of the inverter.

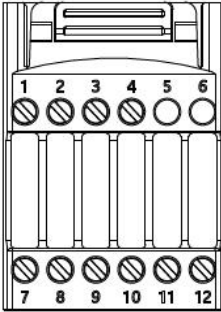

	installed on-site	
Pin	3	4
Label	DRY_RLY1-	DRY_RLY1+
Mode 2	0	
Mode 3	1	

ote: 0-Relay open, 1-Relay closed

Mode 2-Normal operation (0) : Supported by Fox ESS inverter

The heat pump runs in energy-efficient normal mode.

Mode 3-Encouraged operation (1) : Supported by Fox ESS inverter

The operation of the heat pump is encouraged to increase electricity consumption for heating and warm water.

The controller has 2 control models:

- i) The heat pump is switched on.
- ii) The heat pump is switched on AND the warm water temperature is raised.

Configure SG ready power management settings

* SgReadyFunction

* RestartTime (0~65535)s

* SgReadyStartPower (-60000~60000)W

StartPower should be 5000W or more larger than StopPower

* SgReadyStopPower (-60000~60000)W

* SgReadyFunction: Disable/Enable sgreedy function.

* RestartTime: Interval between two launches of sgreedy.

* SgReadyStartPower: when the feed-in power exceeded the set value, the heat pump starts operation.

* SgReadyStopPower: When the feed-in power is less than the set value, the heat pump stops operation.

Note: Zero-feed-in system, if the pv-generation achieves a predefined value (Mode3), The heat pump will start automatically.

DryConfigure setting: DryConfigure Set the DryOut1 to SgReady-1, DryOut2 to SgReady-2.

RTCTime	* DryOut1 <input type="text" value="SgReady-1"/>
BasicParameters1	* DryOut2 <input type="text" value="SgReady-2"/>
OperationMode	* DryIn1 <input type="text" value="N/A"/>
ChargingTime	* DryIn2 <input type="text" value="N/A"/>
BasicParameters2	* DryIn3 <input type="text" value="N/A"/>
ExportLimit	* DryIn4 <input type="text" value="N/A"/>
OffGridParameters	* DryIn0 <input type="text" value="UnexpectedValue"/>
SafetyStartParameters	<input type="button" value="OK"/>
SafetyVoltage	
SafetyFrequency	
Safety-P(f)	
Safety-P(u)	
Safety-Reactive	
AFCI	
AFCISelfTest	
PeakShavingSet	
DieselGen	
DryConfigure	
SgReadyConfigure	

7.5 Reactive Function Setting

Procedures

Step 1

Login fox Cloud.

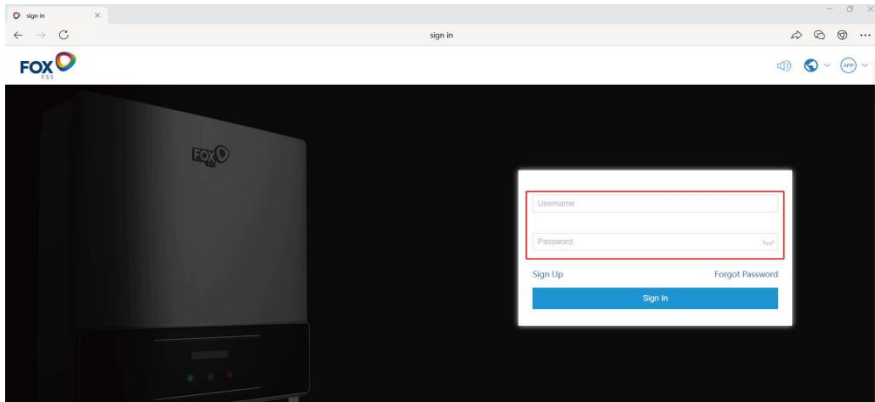

Step 2

Enter SN of Inverter.

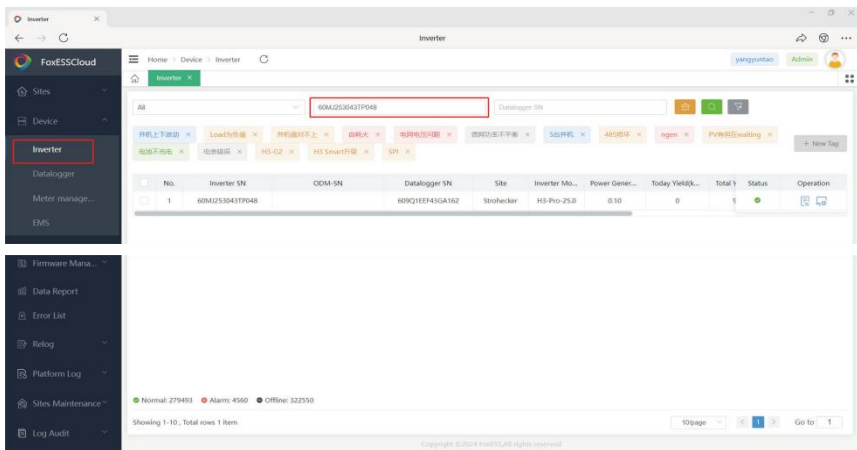

Step 3

Click Here.

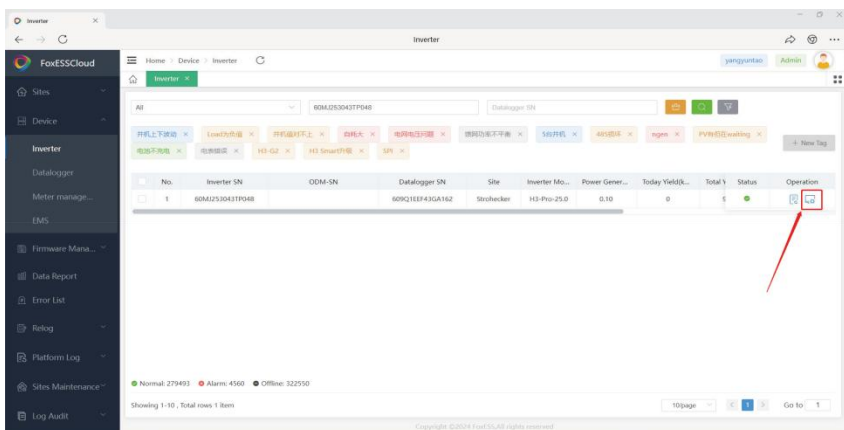

Step 4

Click Safety-Reactive, Select the Reactive Power Mode Enable button.

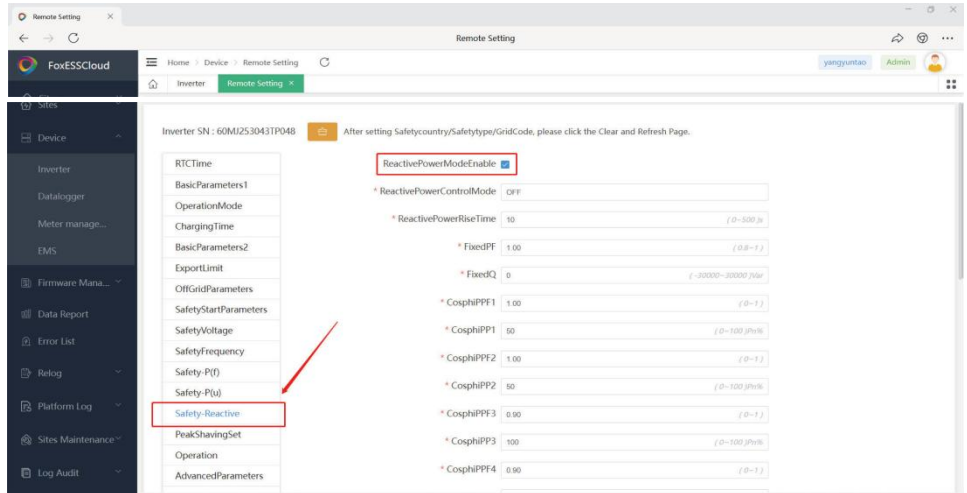
**1. Fixed PF Over**

If you want set the fix PF over, Find the Reactive PowerControl Mode dropdown menu and select the FixedPFOver option;

Set fixed PF parameters according to your needs, with a default value of 1;

* ReactivePowerControlMode

* ReactivePowerRiseTime (0~500)s

* FixedPF (0.8~1)

2. Fixed PF Under

If you want set the fix PF Under, Find the Reactive PowerControl Mode dropdown menu and select the FixedPFUnder option;

Set fixed PF parameters according to your needs, with a default value of 1;

* ReactivePowerControlMode

* ReactivePowerRiseTime (0~500)s

* FixedPF (0.8~1)

3. P and $\cos\phi$ function setting

If you want set the P and $\cos\phi$, Find the Reactive PowerControl Mode dropdown menu and select the $\cos\phi$ (P);

You only need to set the following parameters (CosphiPPF1-4,CosphiPP1-4) according to your needs;

ReactivePowerModeEnable

* ReactivePowerControlMode

* ReactivePowerRiseTime (0-500) s

* FixedPF (0.8-1)

* FixedQ (-30000-30000) VVar

* CosphiPPF1 (0-1)

* CosphiPP1 (0-100) Pn%

* CosphiPPF2 (0-1)

* CosphiPP2 (0-100) Pn%

* CosphiPPF3 (0-1)

* CosphiPP3 (0-100) Pn%

* CosphiPPF4 (0-1)

* CosphiPP4 (0-100) Pn%

4. Fixed Q

If you want set the fix Q, Find the Reactive PowerControl Mode dropdown menu and select the FixedQ option;

Set fixedQ parameters according to your needs;

ReactivePowerModeEnable

* ReactivePowerControlMode

* ReactivePowerRiseTime (0~500)s

* FixedPF (0.8~1)

* FixedQ (-30000~30000)Var

5. Q and U function setting

If you want set the Q and U, Find the Reactive PowerControl Mode dropdown menu and select the Qu;

You only need to set the following parameters (QuV1-4,QuQ1-4) according to your needs;

ReactivePowerModeEnable

* ReactivePowerControlMode

* QuV1 (200~300)V

* QuQ1 (-50~50)%

* QuV2 (200~300)V

* QuQ2 (-50~50)%

* QuV3 (200~300)V

* QuQ3 (-50~50)%

* QuV4 (200~300)V

* QuQ4 (-50~50)%

7.6 DieselGen

P3 PRO inverter, diesel generator with dry contact starting function, ATS backup power supply with normally open contact feedback function.

Single system wiring instruction for dieselgen.

1) Connect the system as shown below:

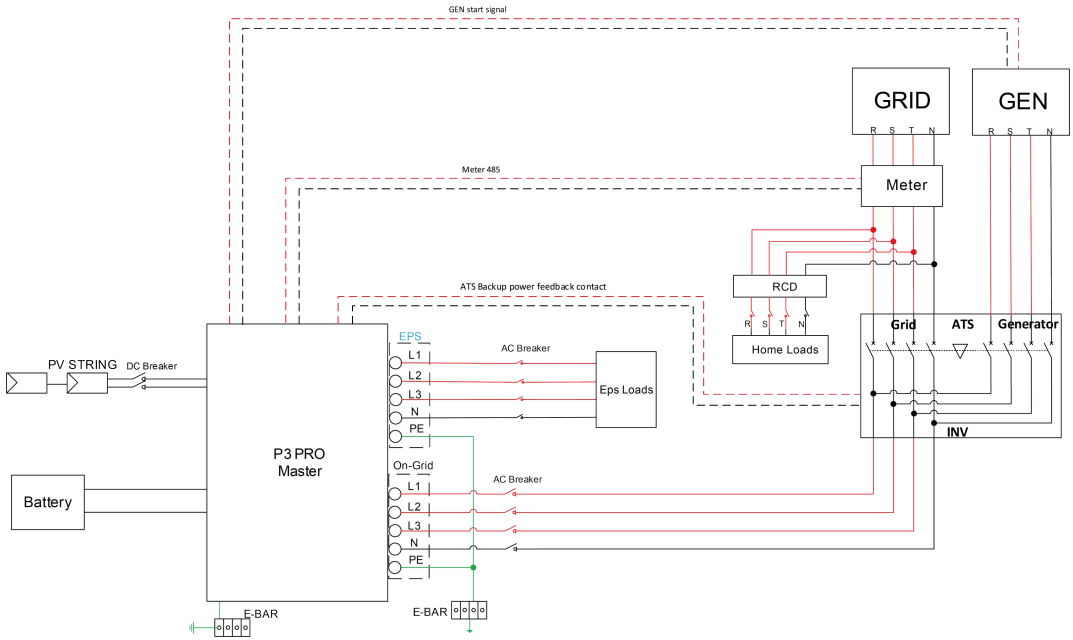

2) Wiring order:

- Power wiring

- Connect the grid to the ATS's normal power port.
- Connect the diesel generator output to the ATS's backup power port.
- Connect the inverter's grid input to the ATS's output port.

- Signal wiring

- Connect PIN3: DRY_RLY1- and PIN4: DRY_RLY1+ of the inverter COM signal port to the two ends of the dry contact input that controls the start of the diesel generator.

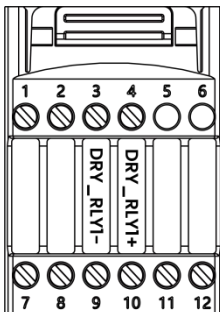

	Relay-2		Relay-1	
Pin	1	2	3	4
Label	DRY_RLY2-	DRY_RLY2+	DRY_RLY1-	DRY_RLY1+

ii) Connect the ATS's backup power supply normally open feedback contact to PIN12 VCC and PIN13 DRM1 of COM24 PIN.

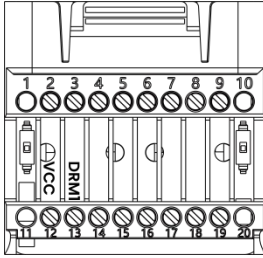

12	13	14	15	16	17	18
VCC	DRM1	DRM2	DRM3	DRM4	DRM0	GND

3) Diesel engine mode settings: Setting-Feature-Gen

- i) GEN Enable Set the diesel generator to enable.
- ii) Start Soc Set the minimum start SOC. If the SOC is lower than this, the diesel generator will start. The default is 20%.
- iii) Stop Soc Set the stop SOC. If the SOC is higher than this, the diesel generator will stop. The default is 90%.
- iv) Gen Charge Allow the diesel generator to charge the battery at a maximum power. The default is 10kw.
- v) Judge Time Set the diesel generator start failure error time. The default is 2min.
- vi) Minimum rest time Set the minimum time interval between two diesel generator starts. The default is 10min.

4) DryConfigure setting

- i) DryConfigure Set the DryOut1 to Diesel, DryIn1 to ATS.
- ii) When the configuration is correct, the ATS normally open contact closes, and the word G appears on the screen.

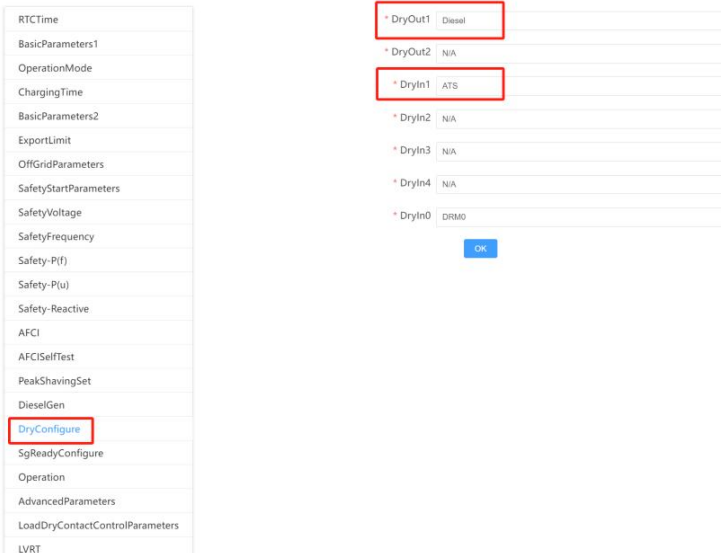

5) Diesel engine mode

Start the inverter normally. The inverter runs normally in diesel generator mode and the screen shows ON Genset.

If there is no power grid on site, only diesel generator (without ATS) wiring scheme should be adopted.

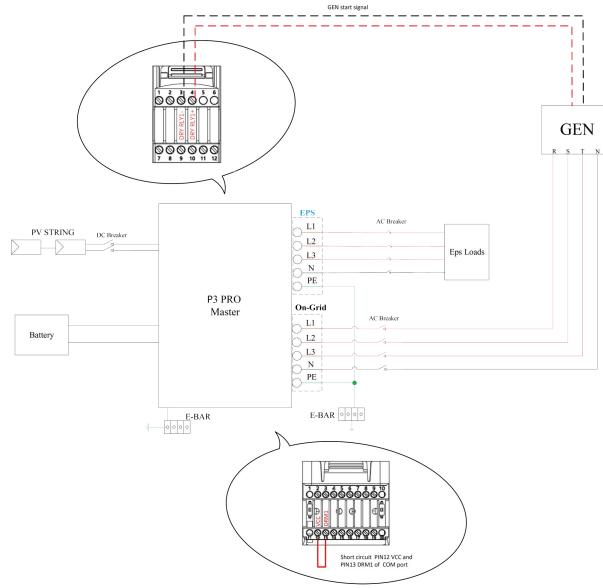

No grid, only access to dieselgen (not connected to ATS)

Parallel system wiring instruction for dieselgen:

1) Connect the system as shown below:

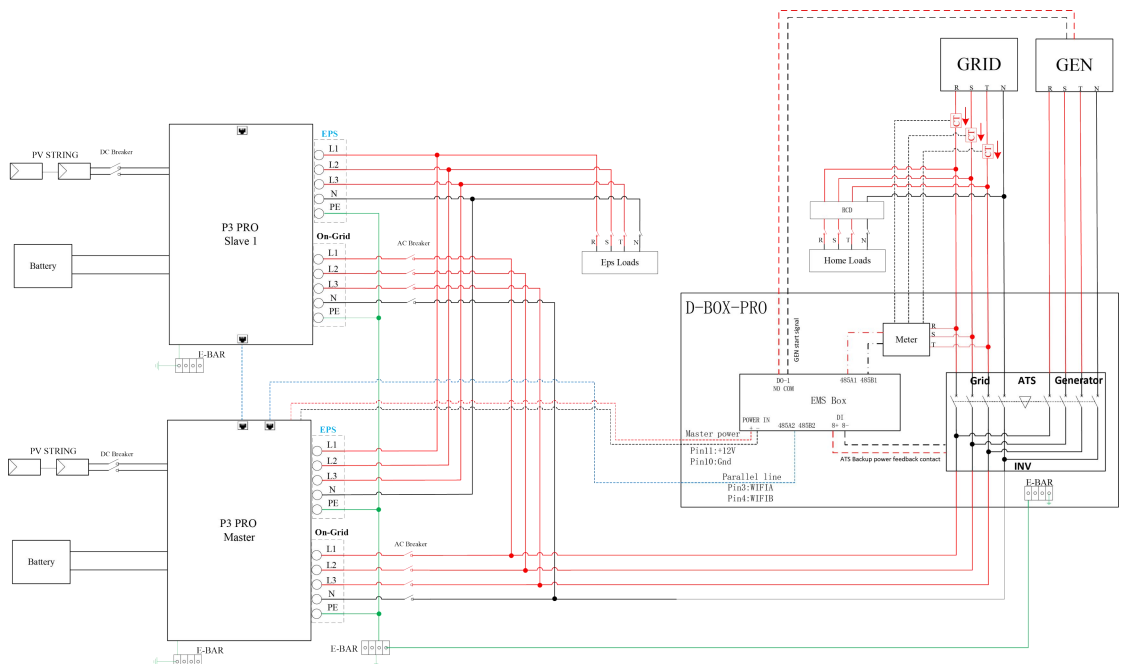

2) Wiring order:

- Power wiring

- i) Connect the grid to the ATS's normal power port.
- ii) Connect the diesel generator output to the ATS's backup power port.
- iii) Connect the inverter's grid input to the ATS's output port.

- Signal wiring

- i) Connect the Smartlogger's DO-1 NO and COM to the two ends of dry contact input that controls the start of the diesel generator.
- ii) Connect the ATS's backup power supply normally open feedback contact to Smartlogger's DI 8+/8-.

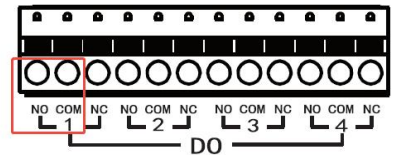
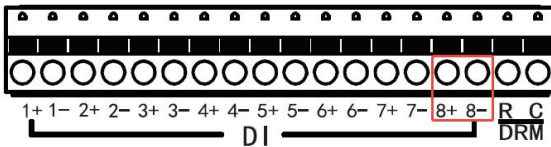

3) Diesel engine mode settings: EMS Configuration-Device Operation-Gen

- i) GEN Enable Set the diesel generator to enable.
- ii) Start Soc Set the minimum start SOC. If the SOC is lower than this, the diesel generator will start. The default is 20%.
- iii) Stop Soc Set the stop SOC. If the SOC is higher than this, the diesel generator will stop. The default is 90%.
- iv) Gen Charge Allow the diesel generator to charge the battery at a maximum power. The default is 10kw.
- v) Judge Time Set the diesel generator start failure error time. The default is 2min.
- vi) Minimum rest time Set the minimum time interval between two diesel generator starts. The default is 10min.

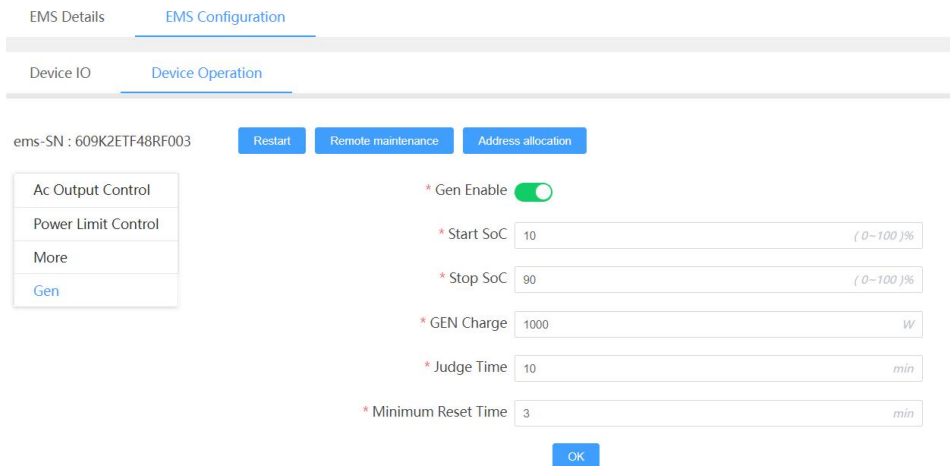

4) Diesel engine mode

Start the inverter normally. The inverter runs normally in diesel generator mode and the screen shows ON Genset.

If there is no power grid on site, only diesel generator (without ATS) wiring scheme should be adopted.

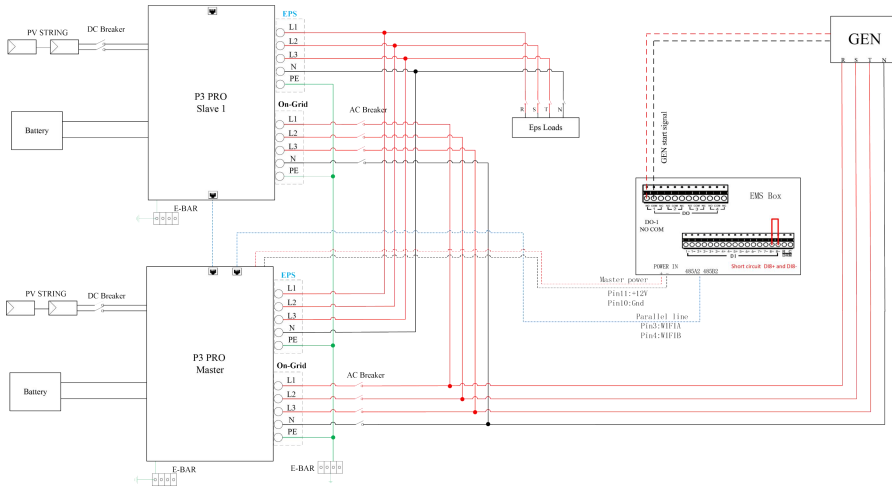

No grid, only access to dieselgen (not connected to ATS)

For AI-Link: Connect PIN3 and PIN6 of the DI/DO cable to dry contact input terminals that control the start of diesel generator; And short circuit PIN1 and PIN2.

Cable Pin	1	2	3	4	5	6	7	8
DC IN/ 12V 1A	DC IN+	DC IN-						
RCR	1-	1+	2+	3+	4+	5+	4-	5-
Inverter			RS485 -A2	RS485 -B2	RS485- A2		GND	12V
DI/DO	8-	8+	DO1 COM	DO2 NO	DO2 COM	DO1 NO	DO3 COM	DO3 NO
Meter/ 485	RS485- B1	RS485 -A1	RS485 -B3	RS485 -A4	RS485- B4	RS485 -A3		

Warning!

1. The ATS Backup power feedback connect only to the COM port (PIN12/PIN13), which ensure a clean signal back. (free from voltage interference)
2. DO NOT connect to live voltage of high-voltage lines.

If accidentally connected to a powered signal or high voltage, it may damage the inverter's MCU, resulting in small squares displayed on the screen.

7.7 EPS Wiring

Primary and secondary load switching wiring diagram

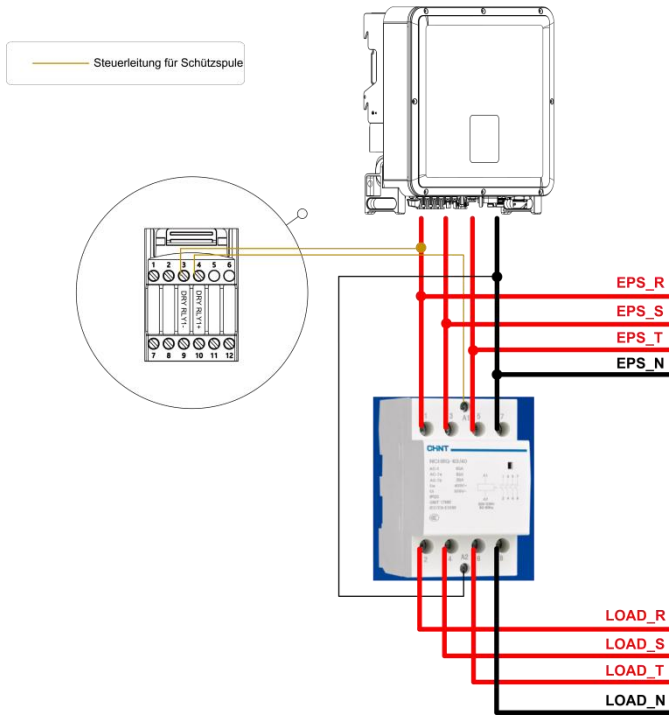

DryConfigure setting: DryConfigure Set the DryOut1 to Smart EPS.

RTCTime
BasicParameters1
OperationMode
ChargingTime
BasicParameters2
ExportLimit
OffGridParameters
SafetyStartParameters
SafetyVoltage
SafetyFrequency
Safety-P(f)
Safety-P(u)
Safety-Reactive
AFCI
AFCISelfTest
PeakShavingSet
DieselGen
DryConfigure

* DryOut1 N/A

* DryOut2 N/A

* DryIn1 SmartEPS

* DryIn2 SgReady-1

* DryIn3 SgReady-2

* DryIn4 LoadCtrl-1

* DryIn5 LoadCtrl-2

* DryIn6 UnexpectedValue

* DryIn7 UnexpectedValue

* DryIn8 UnexpectedValue

* DryIn9 UnexpectedValue

* DryIn10 UnexpectedValue

OK

7.8 Unbalanced Load

Introduction to the function of unbalanced load:

If the load of each phase in the household load is different, and the power of each phase output by the inverter is the same, there will be one phase output and one phase input. In order to avoid this situation, the unbalanced load can be turned on. The use method is to enable in the balance load interface.

The following is a simple schematic diagram of this function:

Disable balance load

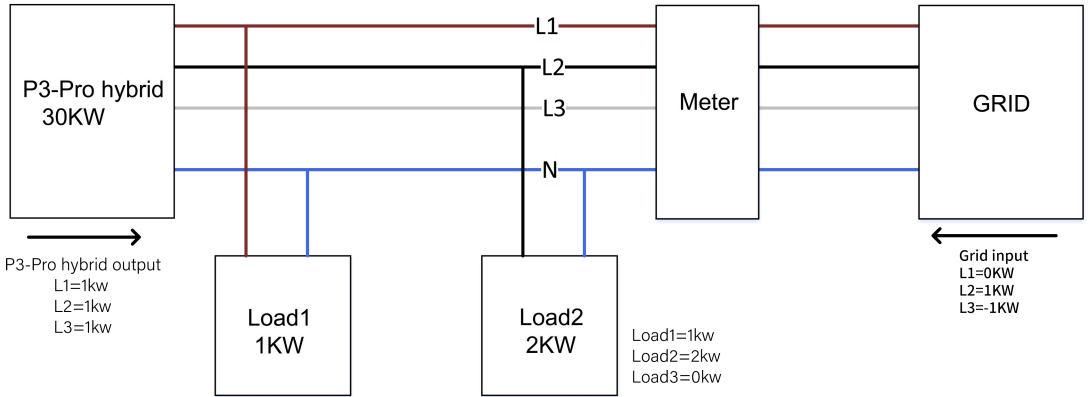

Enable balance load

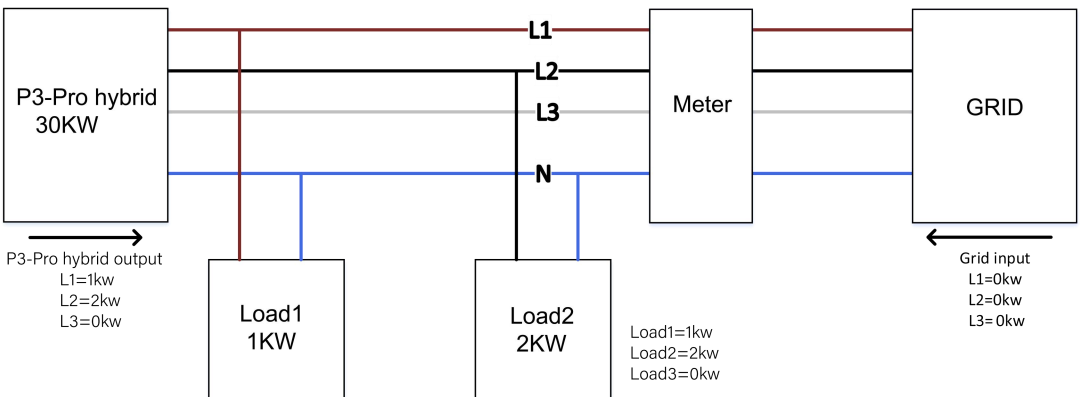

Note!

The maximum capacity of balanced load is 1/3 of the rated power, that is, the maximum output capacity of 30kW machine per phase is 10kW. The same is true for unbalanced load of off-grid function. If the single-phase load exceeds 1/3 of the output capacity under off-grid condition, the machine will report an error.

8 Firmware Upgrading

User can upgrade inverter's firmware via a U-disk.

- **Safety check**

Please ensure the inverter is steadily powered on.

Inverter must keep the battery on through whole procedure of upgrading. Please prepare a PC and make sure the size of U-disk is under 32G, and the format is fat 16 or fat 32.

⚠ Warning!

Please DO NOT apply USB3.0 U-disk on inverter USB port, the inverter USB port only support for USB2.0 U-disk.

- **Upgrading steps:**

Step 1: Please contact our service support to get the update files, and extract it into your U-disk as follow:

update/master/ P3-Pro_E_Master_Vx.xx.bin

update/slave/ P3-Pro_E_Slave_Vx.xx.bin

update/manager/ P3-Pro_Manager_Vx_xx_E.bin

Note: Vx.xx is version number.

Warning: Make sure the directory is in accordance with above form strictly! Do not modify the program file name, or it may cause the inverter not work anymore!

Step 2: Unscrew the waterproof lid and insert U-disk into the "USB" port at the bottom of the inverter.

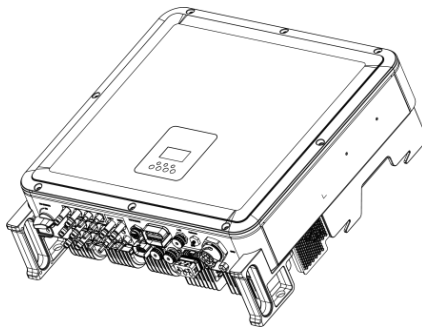

Step 3: The LCD will show the selection menu. Then press up and down to select the one that you want to upgrade and press "OK" to confirm to upgrade.

Step 4: After the upgrade is finished, pull out the U-disk. Screw the waterproof lid.

● **local upgrading:**





USB Upgrade Operation Guide(Apply to P3-Pro)

Introduction: The inverter is a high-tech integrated system with a CPU controller, which requires maintenance and upgrade. The upgrade is easy to operate with by end user or installer, upgrade files will be provided by manufacturer, please prepare everything ready before performing this upgrade.

*The same procedure is used for P3-Pro charger.

Preparations:

1)Prepare one USB 2.0 with memory less than 32G (USB 3.0 incompatibility)

	USB 2.0	USB 3.0
	★★★★☆ (385 ratings)	★★★★☆ (457 ratings)
		
Released	April 2000	November 2008
Speed	High Speed or HS, 480 Mbps (Megabits per second)	10 times faster than USB 2.0. Super Speed or SS, 4.8 Gbps (Giga bits per second)
Signaling Method	Polling mechanism i.e can either send or receive data (Half duplex)	Asynchronous mechanism i.e. can send and receive data simultaneously (Full duplex)
	USB 2.0	USB 3.0
Power Usage	Up to 500 mA	Up to 900 mA. Allows better power efficiency with less power for idle states. Can power more devices from one hub.
Number of wires within the cable	4	9
Standard-A Connectors	Grey in color	Blue in color
Standard-B Connectors	Smaller in size	Extra space for more wires

- 2) Install the USB disk on your laptop, open it and create a folder named 'update'
- 3) Create another three separate subfolders named 'manager' 'master' 'slave' under 'update' folder.
- 4) Put the upgrade file into corresponding folder as shown below

* Formate fo the file name: **Model_Firmware type_Vx_xx**

File names example:

U:\update\master\P3-Pro_Master_Vx_xx

U:\update\slave\P3-Pro_Slave_Vx_xx

U:\update\manager\P3-Pro_Manager_Vx_xx



- 5) Prepare a slotted screwdriver for removing the upgrade portcover.

Upgrade procedure:

1. Turn off AC breaker (main circuit breaker) firstly then turn off DC breaker, make sure the inverter is powered off.
2. Remove the upgrade port cover with a screwdriver.
3. Plug in the USB disk.

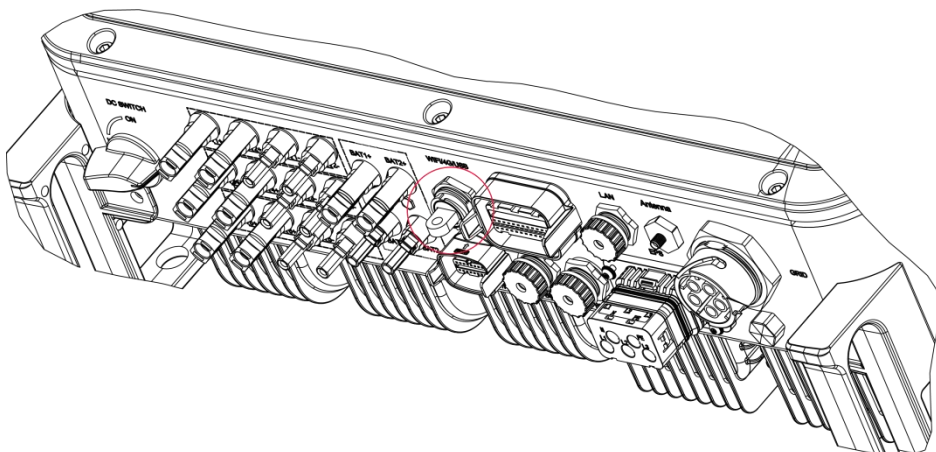

4. Only turn on DC breaker (**make sure PV voltage is above 120V**) wait for 10 seconds, the inverter screen will show as below:

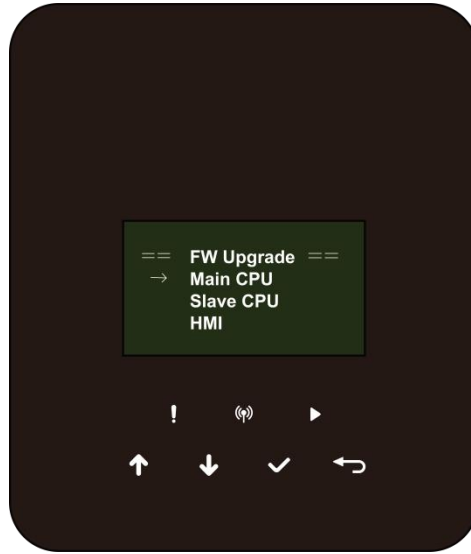

5. If you want to upgrade the inverter firmware, click “up” or “down” to choose the targeted firmware, then click “enter” to start the upgrade. The upgrade will proceed like .

below:

NOTE: Main CPU is “master”, Slave CPU is “slave”, HMI is “manager”.

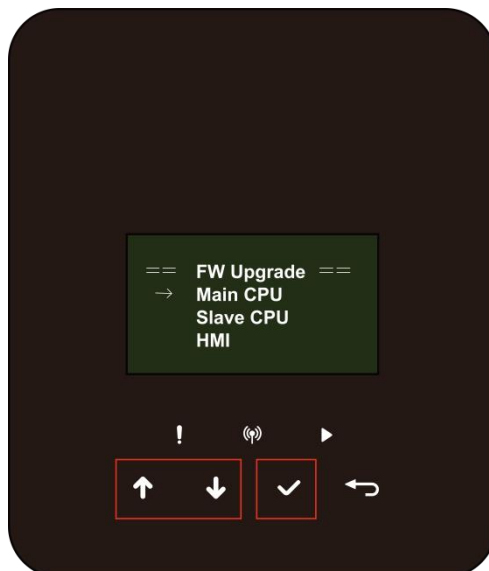

6. Remove the USB disk after upgrade completed. Follow the procedure below and click the option to view the version:

Menu -> About -> Inv Ver

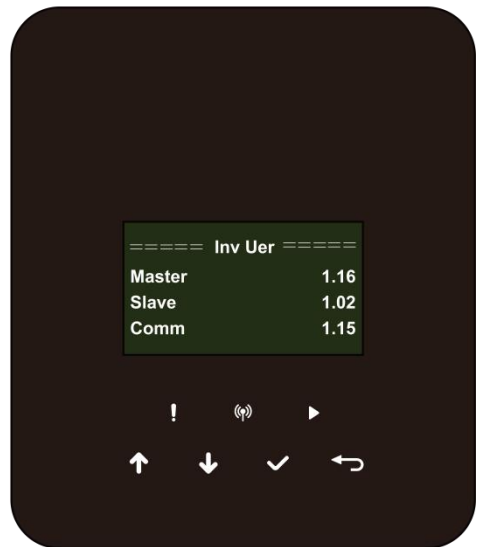
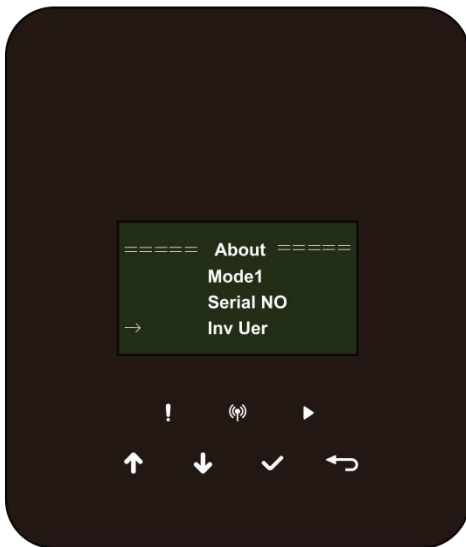
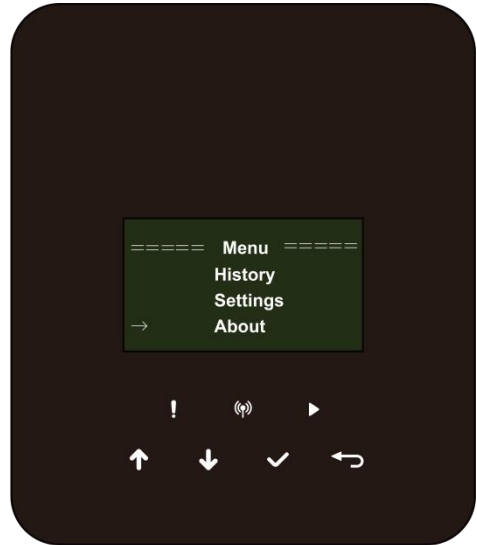
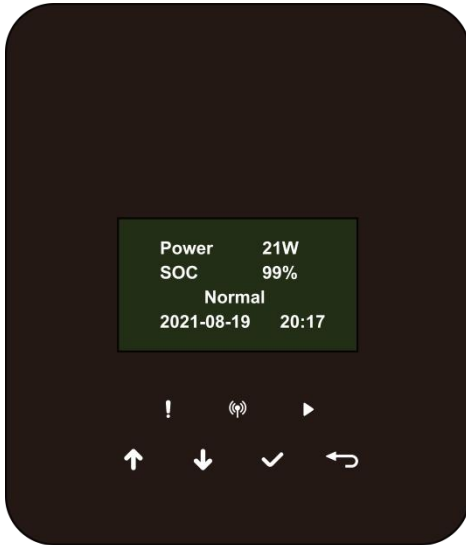

7. Turn on AC & DC breaker. If you updated the HMI, long press the “enter” and click “set” to turn on the inverter. Make sure the inverter can enter **Normal State**.

9 Operation

9.1 Control Panel

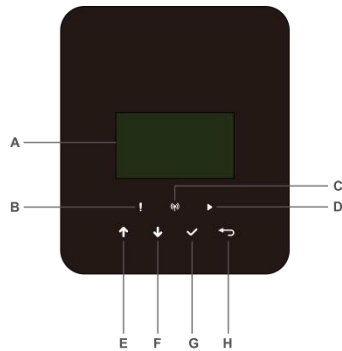

Object	Name	Function
A	LCD screen	Display the information of the inverter.
B	Indicator LED	Red: The inverter is in fault mode.
C		Blue: Light off- No network connection. Blink- connect to the internet. Light on- connection successful.
D		Green: The inverter is in normal state.
E		Function button
F	Down button: Move cursor to downside or decrease value.	
G	OK button: Confirm the selection.	
H	Return button: Return the previous operation.	

1. Press and hold the "√" button on the top of the screen and select "stop" to stop the machine.
2. Disconnect the AC and eps vacs.
3. Rotate DC SWITCH to the off state.
4. Turn off the buttons and control switches on the battery.
5. Wait for the screen on top of the machine to go off.
6. Wait for 5 minutes, this is to ensure that the capacitors inside the machine discharge.
7. Use a current clamp to make sure there is no current on the DC line.
8. Using the tool on the DC terminal, press the two snaps on the DC terminal and pull it outward with force at the same time.
9. Make sure there is no PV positive terminal and no voltage above the PV negative terminal, use a multimeter to measure.
10. Also use a multimeter to measure the PV positive and PV negative terminals to the PE line above the voltage no voltage.
11. Use a tool to disconnect the AC terminal and the terminal for communication.

10 Maintenance

This section contains information and procedures for solving possible problems with the Fox ESS inverters and provides you with troubleshooting tips to identify and solve most problems that can occur.

10.1 Alarm List

Fault Code	Solution
Grid Lost Fault	Grid is lost. <ul style="list-style-type: none"> • System will reconnect if the utility is back to normal. • Or seek help from us, if not go back to normal state.
Grid Volt Fault	Grid voltage out of range. <ul style="list-style-type: none"> • System will reconnect if the utility is back to normal. • Or seek help from us, if not go back to normal state.
Grid Freq Fault	Grid frequency out of range. <ul style="list-style-type: none"> • System will reconnect if the utility is back to normal. • Or seek help from us, if not go back to normal state.
PLL_ OverTime	Three-phase system access single-phase AC. <ul style="list-style-type: none"> • System will reconnect if the utility is back to normal. • Or seek help from us, if not go back to normal state.
10min Volt Fault	The grid voltage is out of range for the last 10 Minutes. <ul style="list-style-type: none"> • System will reconnect if the utility is back to normal. • Or seek help from us, if not go back to normal state.
SW Inv Cur Fault	Output current high detected by software. To upgrade to the latest software, at least ensure that the master is upgraded to 1.69 or above. <ul style="list-style-type: none"> • Disconnect PV, grid and battery, then reconnect. • Or seek help from us, if not go back to normal state.
DCI Fault	DC component is out of limit in output current. <ul style="list-style-type: none"> • Disconnect PV, grid and battery, then reconnect. • Or seek help from us, if not go back to normal state.
HW Inv Cur Fault	Output current high detected by hardware. <ul style="list-style-type: none"> • Disconnect PV, grid and battery, then reconnect. • Or seek help from us, if not go back to normal state.
SW Bus Vol Fault	Bus voltage out of range detected by software. Please check whether the N line is connected to the GRID port of the inverter. To upgrade to the latest software, at least ensure that the master is upgraded to 1.69 or above. <ul style="list-style-type: none"> • Disconnect PV, grid and battery, then reconnect. • Or seek help from us, if not go back to normal state.

Bat Volt Fault	<p>Battery voltage fault.</p> <ul style="list-style-type: none"> • Check if the battery input voltage is within the normal range. • Or seek help from us.
SW Bat Cur Fault	<p>Battery current high detected by software.</p> <ul style="list-style-type: none"> • Disconnect PV, grid and battery, then reconnect. • Or seek help from us, if not go back to normal state.
Iso Fault	<p>The isolation is failed.</p> <ul style="list-style-type: none"> • Please check if the insulation of electric wires is damaged. • Wait for a while to check if back to normal. • Or seek for help from us.
Res Cur Fault	<p>The residual current is high.</p> <ul style="list-style-type: none"> • Please check if the insulation of electric wires is damaged. • Wait for a while to check if back to normal. • Or seek for help from us.
Pv Volt Fault	<p>PV voltage out of range.</p> <ul style="list-style-type: none"> • Please check the output voltage of PV panels. • Or seek for help from us.
SW Pv Cur Fault	<p>PV input current high detected by software.</p> <ul style="list-style-type: none"> • Disconnect PV, grid and battery, then reconnect. • Or seek help from us, if not go back to normal state.
Temp Fault	<p>The inverter temperature is high.</p> <ul style="list-style-type: none"> • Please check if the environment temperature. • Wait for a while to check if back to normal. • Or seek for help from us.
Ground Fault	<p>The ground connection is failed.</p> <ul style="list-style-type: none"> • Check the voltage of neutral and PE. • Check AC wiring. • Disconnect PV, grid and battery, then reconnect. • Or seek help from us, if not go back to normal state.
Over Load Fault	<p>Over load in on grid mode.</p> <ul style="list-style-type: none"> • Please check if the load power exceeds the limit. • Or seek for help from us.
Eps Over Load	<p>Over load in off grid mode.</p> <ul style="list-style-type: none"> • Please check if the eps load power exceeds the limit. • Or seek for help from us.
Bat Power Low	<p>The battery power is low.</p> <ul style="list-style-type: none"> • Wait the battery to be recharged. • Or seek for help from us.
HW Bus Vol Fault	<p>Bus voltage out of range detected by hardware.</p> <ul style="list-style-type: none"> • Disconnect PV, grid and battery, then reconnect. • Or seek help from us, if not go back to normal state.

HW Pv Cur Fault	<p>PV input current high detected by hardware.</p> <p>Check whether PV positive and negative are connected.</p> <ul style="list-style-type: none"> • Disconnect PV, grid and battery, then reconnect. • Or seek help from us, if not go back to normal state.
HW Bat Cur Fault	<p>Battery current high detected by hardware.</p> <ul style="list-style-type: none"> • Disconnect PV, grid and battery, then reconnect. • Or seek help from us, if not go back to normal state.
SCI Fault	<p>The communication between master and manager is fail.</p> <ul style="list-style-type: none"> • Disconnect PV, grid and battery, then reconnect. • Or seek help from us, if not go back to normal state.
MDSP SPI Fault	<p>The communication between master and slave is fail.</p> <ul style="list-style-type: none"> • Disconnect PV, grid and battery, then reconnect. • Or seek help from us, if not go back to normal state.
MDSP Smpl Fault	<p>The master sample detection circuit is failed.</p> <ul style="list-style-type: none"> • Disconnect PV, grid and battery, then reconnect. • Or seek help from us, if not go back to normal state.
Res Cur HW Fault	<p>Residual current detection device is failed.</p> <ul style="list-style-type: none"> • Disconnect PV, grid and battery, then reconnect. • Or seek help from us, if not go back to normal state.
Inv EEPROM Fault	<p>The inverter eeprom is fault.</p> <ul style="list-style-type: none"> • Disconnect PV, grid and battery, then reconnect. • Or seek help from us, if not go back to normal state.
PvCon Dir Fault	<p>The PV connection is reversed.</p> <ul style="list-style-type: none"> • Check if the positive pole and negative pole of PV are correctly connected. • Or seek help from us.
Bat Relay Open	<p>The battery relay keeps open.</p> <ul style="list-style-type: none"> • Disconnect PV, grid and battery, then reconnect. • Or seek help from us, if not go back to normal state.
Bat Relay Short Circuit	<p>The battery relay keeps close.</p> <ul style="list-style-type: none"> • Disconnect PV, grid and battery, then reconnect. • Or seek help from us, if not go back to normal state.
Bat Buck Fault	<p>The battery buck circuit mosfet is fail.</p> <ul style="list-style-type: none"> • Disconnect PV, grid and battery, then reconnect. • Or seek help from us, if not go back to normal state.
Bat Boost Fault	<p>The battery boost circuit mosfet is fail or The relay on the battery side of the inverter is not closed.</p> <p>To upgrade to the latest software, at least ensure that the master is upgraded to 1.69 or above.</p> <ul style="list-style-type: none"> • Disconnect PV, grid and battery, then reconnect. • Or seek help from us, if not go back to normal state.
Eps Relay Fault	<p>The eps relay is failed.</p> <ul style="list-style-type: none"> • Disconnect PV, grid and battery, then reconnect. • Or seek help from us, if not go back to normal state.

BatCon Dir Fault	<p>The battery connection is reversed.</p> <ul style="list-style-type: none"> • Check if the positive pole and negative pole of battery are correctly connected. • Or seek help from us.
Grid Relay Fault	<p>The grid relay keeps open or close.</p> <ul style="list-style-type: none"> • Disconnect PV, grid and battery, then reconnect. • Or seek help from us, if not go back to normal state.
RDSP SPI Fault	<p>The communication between master and slave is fail.</p> <ul style="list-style-type: none"> • Disconnect PV, grid and battery, then reconnect. • Or seek help from us, if not go back to normal state.
RDSP SmpI Fault	<p>The slave sample detection circuit is failed.</p> <ul style="list-style-type: none"> • Disconnect PV, grid and battery, then reconnect. • Or seek help from us, if not go back to normal state.
ARM EEPROM Fault	<p>The manager eeprom is fault.</p> <ul style="list-style-type: none"> • Disconnect PV, grid and battery, then reconnect. • Or seek help from us, if not go back to normal state.
Meter Lost Fault	<p>The communication between meter and inverter is interrupted.</p> <ul style="list-style-type: none"> • Check if the communication cable between meter and inverter is correctly and well connected.
BMS Lost	<p>The communication between BMS and inverter is interrupted.</p> <ul style="list-style-type: none"> • Check if the communication cable between BMS and inverter is correctly and well connected.
Bms Ext Fault	<p>The communication between BMS and inverter is interrupted.</p> <ul style="list-style-type: none"> • Check if the communication cable between BMS and inverter is correctly and well connected.
Bms Int Fault	<p>DIP switch at the wrong position; The communication between battery packs is interrupted.</p> <ul style="list-style-type: none"> • Move the DIP switch to the correct position; • Check if the communication cable between battery packs is correctly and well connected.
Bms Volt High	<p>Battery over voltage.</p> <ul style="list-style-type: none"> • Please contact battery supplier.
Bms Volt Low	<p>Battery under voltage.</p> <ul style="list-style-type: none"> • Please contact battery supplier.
Bms ChgCur High	<p>Battery charge over current.</p> <ul style="list-style-type: none"> • Please contact battery supplier.
Bms DchgCur High	<p>Battery discharge over current.</p> <ul style="list-style-type: none"> • Please contact battery supplier.

Bms Temp High	Battery over temperature. • Please contact battery supplier.
Bms Temp Low	Battery under temperature. • Please contact battery supplier.
BmsCellImbalance	The capacities of cells are different. • Please contact battery supplier.
Bms HW Protect	Battery hardware under protection. • Please contact battery supplier.
BmsCircuit Fault	Bms hardware circuit fault. • Please contact battery supplier.
Bms Insul Fault	Battery insulation fault. • Please contact battery supplier.
BmsVoltsSen Fault	Battery voltage sensor fault. • Please contact battery supplier.
BmsTempSen Fault	Battery temperature sensor fault. • Please contact battery supplier.
BmsCurSen Fault	Battery current sensor fault. • Please contact battery supplier.
Bms Relay Fault	Battery relay fault. • Please contact battery supplier.
Bms Type Unmatch	The capacity of battery packs is different. • Please contact battery supplier.
Bms Ver Unmatch	The software between slaves are different. • Please contact battery supplier.
Bms Mfg Unmatch	The cell manufacture is different. • Please contact battery supplier.
Bms SwHw Unmatch	The slave software and hardware are not match. • Please contact battery supplier.
Bms M&S Unmatch	The software between Master and Slave are not match. • Please contact battery supplier.
Bms ChgReq NoAck	No action for charging request. • Please contact battery supplier.

10.2 Troubleshooting and Routine Maintenance

● Troubleshooting

- a. Please check the fault message on the System Control Panel or the fault code on the inverter information panel. If a message is displayed, record it before doing anything further.
- b. Attempt the solution indicated in table above.
- c. If your inverter information panel is not displaying a fault light, check the following to make sure that the current state of the installation allows for proper operation of the unit:
 - (1) Is the inverter located in a clean, dry, adequately ventilated place?
 - (2) Have the DC input breakers opened?
 - (3) Are the cables adequately sized?
 - (4) Are the input and output connections and wiring in good condition?
 - (5) Are the configurations settings correct for your particular installation?
 - (6) Are the display panel and the communications cable properly connected and undamaged?

Contact Customer Service for further assistance. Please be prepared to describe details of your system installation and provide the model and serial number of the unit.

● Safety check

A safety check should be performed at least every 12 months by a qualified technician who has adequate training, knowledge and practical experience to perform these tests. The data should be recorded in an equipment log. If the device is not functioning properly or fails any of the tests, the device has to be repaired. For safety check details, refer to section 2 of this manual.

● Maintenance checking list

During the process of using the inverter, the responsible person shall examine and maintain the machine regularly. The required actions are as follows.

- Check that if the cooling fins at the rear of the inverters are collecting dust/dirt, and the machine should be cleaned when necessary. This work should be conducted periodically.
- Check that if the indicators of the inverter are in normal state, check if the display of the inverter is normal. These checks should be performed at least every 12 months.
- Check if the input and output wires are damaged or aged. This check should be performed at least every 12 months.
- Get the inverter panels cleaned and their security checked at least every 6 months.

Note: Only qualified individuals may perform the following works.

11 Decommissioning

11.1 Disassembling the Inverter

- Disconnect the inverter from the DC input and AC output. Wait for 5 minutes to ensure the inverter is completely powered down.
- Disconnect communication cables and any optional monitoring modules. Remove the inverter from the wall mounting bracket.

If possible, use the original packaging to repack the inverter. If the original packaging is unavailable, an equivalent box meeting the following requirements may be used:

- Capable of bearing a weight of 30 kg.
- Includes handles.
- Can be fully enclosed

11.2 Storing the Inverter

If the inverter is not put into operation immediately, it must be stored under specific environmental conditions.

- Regularly inspect the storage condition of the inverter. Check for moisture, mold, or signs of pest/rodent infestation. Replace packaging materials promptly if necessary.
- The equipment must be stored in a dry, well-ventilated area with a relatively stable temperature, consistently maintained between -30°C and 60°C , and a relative humidity range of 5% to 95%. Avoid direct sunlight and keep a distance of $\geq 2\text{m}$ from heat sources.
- Avoid locations subject to water splashing, rain, dampness, high temperatures, or outdoor exposure. If the floor is damp, place the packaging box on a shelf or elevated platform to avoid direct contact with the ground and minimize moisture risk.
- The storage area must be free of harmful gases, flammable, explosive materials, and corrosive chemicals.
- For long-term storage, the equipment must be covered or appropriate measures taken to protect it from contamination and environmental impact.
- Avoid mechanical shock, heavy pressure, strong electric fields, and strong magnetic fields.
- When stacking multiple inverters, do not exceed 4 cartons in height.
- Products stored under the above conditions for more than 12 months must undergo capacity verification tests and re-inspection before they can be used.

Note: Please adhere to the storage requirements. Product damage caused by failure to meet these conditions is not covered under warranty.

11.3 Transporting the Inverter

- Ensure the product is securely packaged before vehicle transport. Use enclosed containers for long-distance transportation.
- It is strictly prohibited to transport this product together with equipment or items that could potentially affect or damage it.

11.4 Decommissioning/Scrapping the Inverter

- Certain components of the inverter may cause environmental pollution. When disposing of the inverter or its related components, ensure compliance with local waste disposal regulations.

12 Appendix

12.1 Quality Guarantee

FOXESS Co., Ltd. (hereinafter referred to as "the Company") will, for products found to be faulty during the warranty period, repair the product free of charge or replace it with a new one.

Supporting Documentation Required

When requesting warranty service, the customer must present the original purchase invoice indicating the date of purchase. Furthermore, the product's trademark must be clearly visible. The Company reserves the right to decline warranty coverage if these conditions are not met.

Relevant Conditions

- Non-conforming products replaced under warranty shall be disposed of by the Company.
- The customer must allow the Company a reasonable period of time to complete repairs on faulty equipment.

Warranty Exclusions

The Company reserves the right to decline warranty coverage under the following circumstances:

- The entire machine or specific components have exceeded the free warranty period.
- Damage incurred during transportation.
- Faults resulting from incorrect installation, modification, or use.
- Operation in environments that exceed the limits specified as harsh in this manual.
- Malfunctions or damage caused by installation, repair, alteration, or disassembly performed by service organizations or personnel not authorized by the Company.
- Use or installation outside the scope defined in the relevant international standards.
- Damage caused by abnormal natural disasters.
- Damage resulting from storage conditions that do not meet the requirements stated in the product documentation.
- Any losses arising from failure to adhere to the safety precautions outlined in this manual.

If a product failure is caused by any of the above circumstances and the customer still requests repair services, the Company's authorized service organization may, upon assessment, provide repair services subject to a charge.

Other Provisions

The Company reserves the right to change product dimensions and parameters based on its latest documentation without prior notice.

12.2 Contact Us

If you have any questions about the product, please contact us:

- Fox ESS Headquarters: No.939, Jinhai Third Road, New Airport Industry Area, Longwan District, Wenzhou, Zhejiang, China.
- Wuxi R&D Center: No. 97 Huaqing Avenue, Wuxi Economic Development Zone (Intersection of Huaqing Avenue and Huayun Road)
- Wuhan R&D Center: No.5, Jiayuan Road, Hongshan District, Wuhan, Hubei, China
- Shanghai R&D Center: No.1255, Jinhai Road, Pudong New Area, Shanghai, China
- After-Sales Service Hotline: 400 1888 900
- Contact Telephone (Wenzhou): 0577-88159999
- Contact Telephone (Wuxi): 0510-68092998
- Contact Us: info@fox-esscom
- Contact Us (EV Charger): ev@fox-esscom
- After-Sales Service: service@fox-esscom